

## OPPD Board of Directors – All Committees Meeting

Tuesday, October 19, 2021

CLOSED SESSION – 8:00 AM – PUBLIC SESSION 10:00 A.M.

Public may attend by going to [www.oppd.com/CommitteeAgenda](http://www.oppd.com/CommitteeAgenda) to access the Webex meeting link and view instructions.

	<u>TOPIC</u>	<u>TYPE</u>	<u>PRESENTER</u>	<u>TIME*</u>
1.	Chair Opening Statement		Bogner	8:00 A.M.
2.	Closed Session			8:10 A.M.
	Power with Purpose Update	Reporting	Fisher	45 min
	Cyber and Physical Security Update	Reporting	Brown	35 min
	CFO Appointment and Compensation Approval	Action	Fernandez	15 min
	<b>BREAK</b>			9:40 A.M.
	<i>Open Webex Meeting to Allow Public to Join</i>			9:45 A.M.
3.	Public Session – Chair Opening Statement		Bogner	10:00 A.M.
4.	Safety Briefing		Fernandez	10:05 A.M.
5.	Governance Committee			10:10 A.M.
	Governance Chair Report (10/14/21)	Reporting	Moody	10 min
	CFO Appointment and Compensation Approval	Action	Fernandez	15 min
	SD-12: Information Management and Security Monitoring Report	Action	Brown	15 min
6.	Finance Committee			10:50 A.M.
	Finance Chair Report (10/8/21)	Reporting	Yoder	10 min
	Settlement with the Nebraska Dep't of Revenue	Reporting	Thurber	10 min
	Green Power Update	Reporting	Comstock	30 min
	<b>BREAK FOR LUNCH</b>			11:40 A.M.
7.	System Management & Nuclear Oversight Cmte			12:10 P.M.
	SM&NO Chair Report (10/6/21)	Reporting	Williams	10 min
	North Omaha Station Unit 4 and 5 Burner Replacement – Engineer's Certificate to Negotiate	Action	Fisher	10 min
	Jones Street Station Exhaust Stack Replacements – Engineer's Certification	Action	Fisher	10 min
	RFP 5911 – Steel Structures	Action	Via	5 min
	Nuclear Oversight Committee Report	Reporting	Fisher	30 min
	SD-7: Environmental Stewardship Monitoring Report	Action	Fisher	60 min
	<b>BREAK</b>			2:15 P.M.
8.	Public Information Committee			2:20 P.M.
	Public Information Chair Report (10/12/21)	Reporting	Mollhoff	10 min
	• Note: Due to time, Customer Trends Quarterly Update will be posted on OPPD.com			
	Legislative and Regulatory Update	Reporting	Olson	15 min
	SD-13: Stakeholder Outreach and Engagement Monitoring Report	Action	Olson	45 min

*Continued next page*

\* All times and duration are estimates. Please use the link below to find board agendas, materials and schedules. Board governance policies and contact information for the board and senior management team also can be found at [www.oppd.com/BoardMeetings](http://www.oppd.com/BoardMeetings).

<u>TOPIC</u>	<u>TYPE</u>	<u>PRESENTER</u>	<u>TIME*</u>
<b>9. Other Business</b>			<b>3:30 P.M.</b>
Confirmation of Board Meeting Agenda	Action	Bogner	5 min
Review of Board Work Plan	Discussion	Bogner	5 min
Power with Purpose Update	Reporting	Fisher	15 min
Pathways to Decarbonization Strategic Initiative Update	Presentation	Fisher	60 min



## Pre-Committee Agenda

GOVERNANCE PRE-COMMITTEE MEETING  
WEBEX VIDEOCONFERENCE  
October 14, 2021 8:00 – 9:00 A.M.

1. CFO Appointment and Compensation Approval (Fernandez – 10 min)
  - a. Objective: Align around recommendation for appointment and compensation.
2. OPPD Redistricting – Amendment to OPPD's Petition for Creation (Bruckner – 20 min)
  - a. Objective: Update on status to make a well-informed and timely recommendation regarding OPPD redistricting.
3. 2021 Board Governance Workshop Debrief (Focht – 15 min)
  - a. Objective: Align on initial actions and next steps. (e.g. summary of committee direction, confirmation of board work plan)
4. SD-12: Information Management and Security Monitoring Report (Brown – 5 min)
  - a. Objective: Confirm recommendation and address any questions.
5. Cyber and Physical Security Update (Brown – 5 min)
  - a. Objective: Confirm topic and address any questions.
6. Confirmation of Board Work Plan – Governance Committee Items (2 min)
  - a. Objective: Committee members to review and confirm items on the Board Work Plan.
7. Summary of Committee Direction (2 min)
  - a. Objective: Senior management team liaison(s) to summarize direction provided by the committee.



# Board Action

## BOARD OF DIRECTORS

October 19, 2021

### ITEM

SD-12: Information Management and Security Monitoring Report

### PURPOSE

To ensure full board review, discussion and acceptance of SD-12: Information Management and Security Monitoring Report.


### FACTS

- a. The first set of Board policies was approved by the Board on July 16, 2015. A second set of Board policies was approved by the Board on October 15, 2015.
- b. Each policy was evaluated and assigned to the appropriate Board Committee for oversight of the monitoring process.
- c. The Governance Committee is responsible for evaluating Board Policy SD-12: Information Management and Security.
- d. The Governance Committee has reviewed and accepted the SD-12: Information Management and Security Monitoring Report and finds that OPPD is taking reasonable and appropriate measures to comply with the policy.

### ACTION

The Governance Committee recommends Board approval of the 2021 SD-12: Information Management and Security Monitoring Report.

#### RECOMMENDED:

DocuSigned by:  
  
51E67D99EF881470  
 Kathleen W. Brown  
 Vice President and Chief Information Officer

#### APPROVED FOR BOARD CONSIDERATION:

DocuSigned by:  
  
AC399EDCE56247E  
 L. Javier Fernandez  
 President and Chief Executive Officer

Attachments:  
Exhibit A – Monitoring Report  
Resolution



Exhibit A

# SD-12: Information Management and Security Monitoring Report

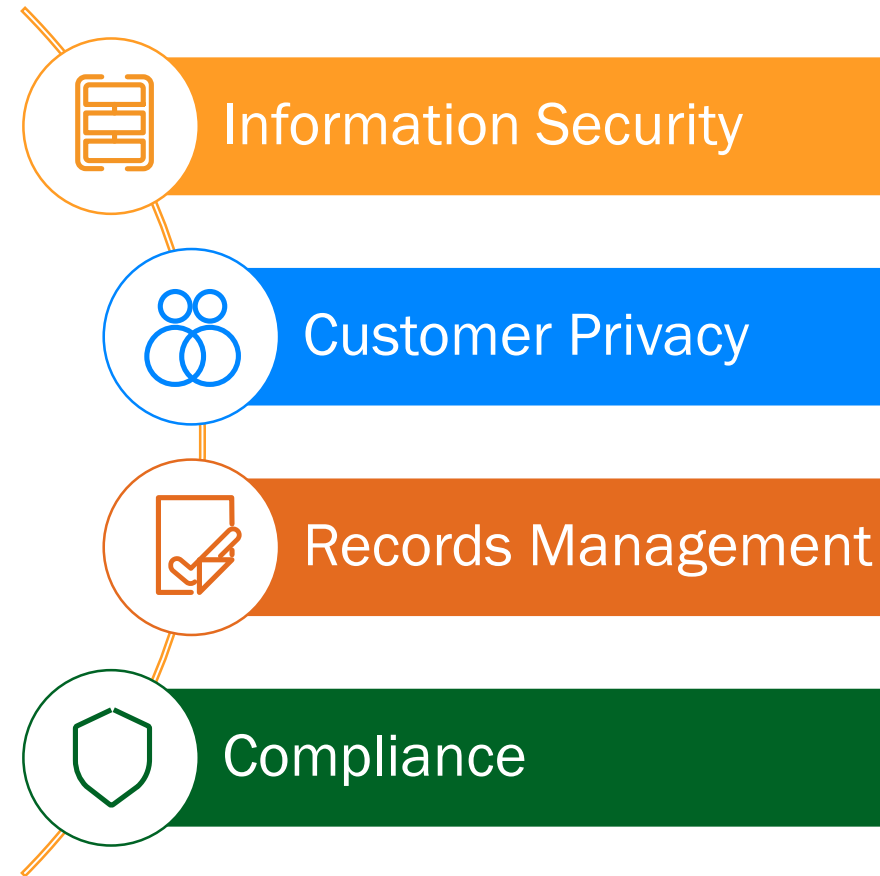
Governance Committee Report

October 2021

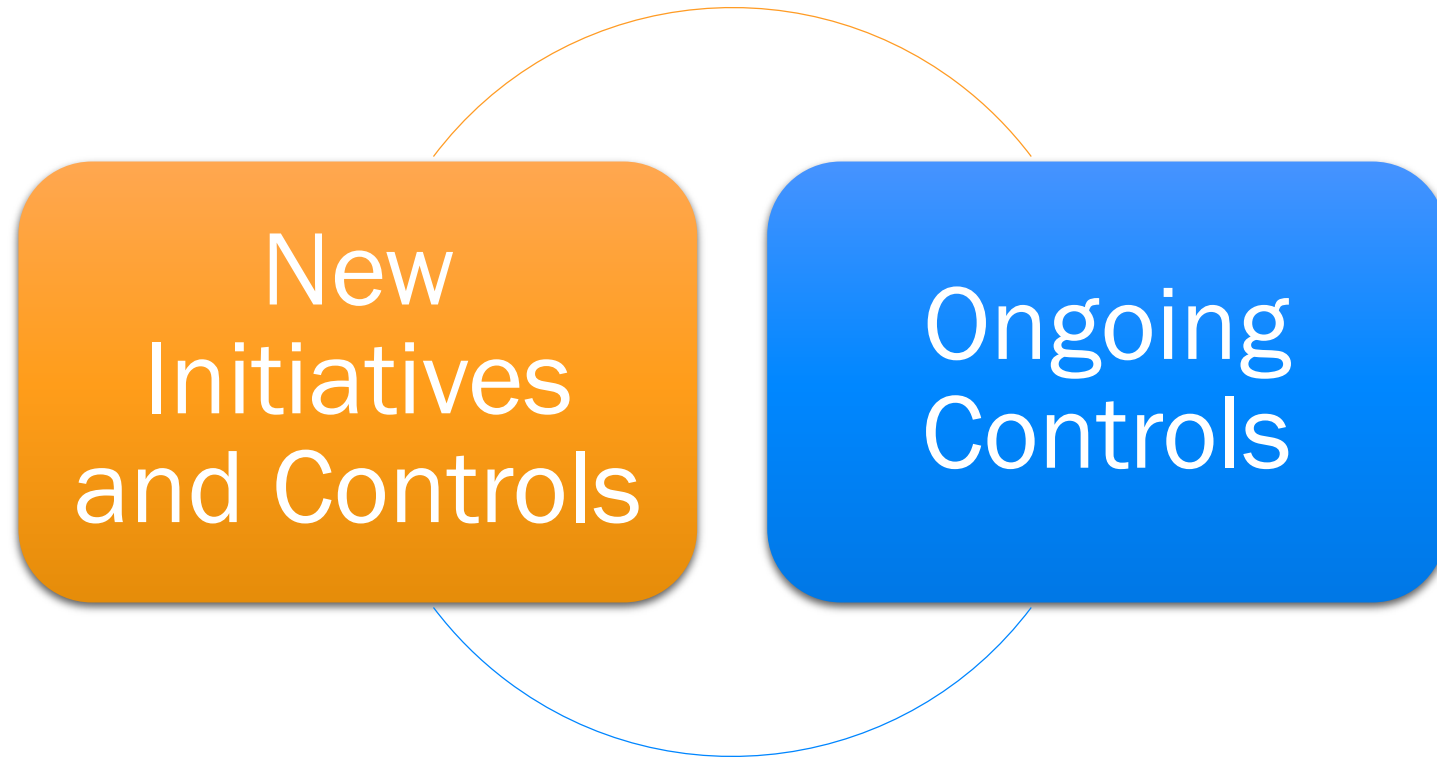


# SD-12: Information Management & Security

- Robust information management and security practices are critical to effective risk management and to ensure regulatory compliance, business resiliency and customer-owner satisfaction
- OPPD shall safeguard and protect data, information and assets from inappropriate use, improper disclosure and unauthorized release



# Ensuring Compliance to SD-12



# Information Security



## Objective

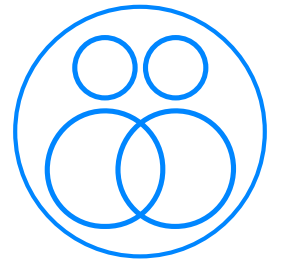
- OPPD will implement processes and methodologies to protect print, electronic, or any other form of information or data from unauthorized access, misuse, disclosure, destruction, or modification

## Ongoing Controls

- Maturing our capabilities to identify and respond to cybersecurity events
- Identifying and mitigating known vulnerabilities based on risk to the organization
- Conducting regular cybersecurity incident response exercises to test and improve our processes
- Establishing and maturing plans, procedures, and technologies to detect, analyze, and respond to cybersecurity events
- Leveraging partnerships to collect and provide cybersecurity information, including threats and vulnerabilities, to reduce risks and to increase operational resilience
- Maturing our security awareness services with a focus on phishing prevention
- Creating security awareness to all employees through training and communications



# Customer Privacy



## Objective

- Except as provided by law or for a business purpose, OPPD will not disseminate customer-owner information to a third party for non-OPPD business purposes without customer-owner consent
- Where sensitive and confidential information is disseminated for a business purpose, OPPD will ensure that the third party has information practices to protect the sensitive and confidential customer-owner information
- OPPD will maintain a process that identifies the business purposes for which OPPD will collect, use and disseminate sensitive and confidential customer-owner information

## Ongoing Controls

- OPPD's Identity Theft Prevention Program is the cornerstone for ensuring customer privacy throughout OPPD
  - This program is reviewed regularly for effectiveness and compliance with state and federal regulations
  - An annual report of this program is reviewed by OPPD management to ensure its effectiveness
  - All employees with access to customer information are trained based on this program, including annual training and regular assessments in relation to data sharing and security
- Customer Service and Public Affairs teams partner to provide customer communications based on fraud-related trends and events

# Records Management

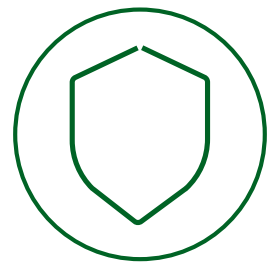


## Objective

- The efficient and systematic control of the creation, capture, identification, receipt, maintenance, use, disposition, and destruction of OPPD records, in accordance with legal requirements

## Ongoing Controls

- Ensuring records management staff are trained on practices and have procedures for maintaining, archiving and destruction of required business records
- Leveraging industry and external partnerships, including outside utilities and government entities
- Continuing process and service improvements in light of efficiency, effectiveness and security
- Strengthening collaboration across OPPD in the area of records management
- Supporting records management efforts associated with FCS nuclear decommissioning and other EPND activities



# Compliance – Ongoing Controls

## Objective

- Comply with contractual and legal requirements through the use of technical controls, system audits and legal review

## Ongoing Controls

- Strengthening governance, risk and compliance capabilities through formal enterprise management, identification and attestations of control compliance
- Engaging employees, legal counsel and external entities to stay abreast of the changing landscape from a legal/compliance perspective
- Confirming that security and privacy measures are included in contracting processes for the protection of OPPD data and systems, and also supported by our engaged third parties
- Performing internal and external audits and reviews on a regular basis, with findings provided to management

# Progress in 2021

## Information Security



- Strengthened security through specialized training and awareness activities
- Increased focus on vendor risk management
- Strengthened the governance and management of Information Security, enhancing integration of security capabilities in technology solutions
- Increased threat awareness through industry and data sharing partnerships

## Records Management



- Continued development of records management function
- Completed retention schedule review, seeking State of Nebraska Records Management Office approval
- Leveraged industry and external partnerships
- Supported records management efforts associated with FCS nuclear decommissioning and EPND activities

## Customer Privacy



- Enhanced scam prevention tactics and continued proactive requests to shut down toll free numbers known to be used to defraud OPPD customers
- Brought greater visibility to area scam activities through utility partnerships
- Requested shut down of suspicious non-toll free numbers
- Introduced new methods of customer education: NextDoor & email

## Compliance



- Strengthened security policy (and associated controls), further aligning to established best practices, industry standards, and regulatory recommendations and requirements
- Increased focus on digital transformation, cloud technology growth and OT/IT convergence
- Completed internal and external maturity assessments of critical capabilities, threat and vulnerability management

# Recommendation

- The Governance Committee has reviewed and accepted this Monitoring Report for SD-12 and finds that OPPD is taking reasonable and appropriate measures to comply with Board Policy SD-12

# Questions





Moody/Brown

**DRAFT**  
**RESOLUTION NO. 64xx**

**WHEREAS**, the Board of Directors has determined it is in the best interest of the District, its employees, and its customer-owners to establish written policies that describe and document OPPD's corporate governance principles and procedures; and

**WHEREAS**, each policy was evaluated and assigned to the appropriate Board Committee for oversight of the monitoring process; and

**WHEREAS**, the Board's Governance Committee (the "Committee") is responsible for evaluating Board Policy SD-12: Information Management and Security on an annual basis. The Committee has reviewed the 2021 SD-12: Information Management and Security Monitoring Report and finds OPPD is taking reasonable and appropriate measures to comply with Board Policy SD-12 as stated.

**NOW, THEREFORE, BE IT RESOLVED** that the Board of Directors of Omaha Public Power District accepts the 2021 SD-12: Information Management and Security Monitoring Report, in the form as set forth on Exhibit A attached hereto and made a part hereof, and finds that OPPD is taking reasonable and appropriate measures to comply with Board Policy SD-12: Information Management and Security.




## Pre-Committee Agenda

### FINANCE PRE-COMMITTEE MEETING VIDEOCONFERENCE

October 8, 2021 8:00 – 9:30 AM

1. Preliminary 2022 Rate Increase Overview (Thurber/Underwood – 10 min)
  - a. Objective: Share the preliminary rate increase amount and reasons for the increase.
2. Settlement with Nebraska Department of Revenue on Sales Tax Audit (Thurber – 10 min)
  - a. Objective: Review settlement with NDOR on sales tax audit.
3. Green Power Rate Update (Comstock – 10 min)
  - a. Objective: Update Committee on possible changes to Green Power rate.
4. SD-2: Rates Policy Revision (Yoder – 55 min)
  - a. Objective: Committee members to discuss proposed revisions to policy with respect to monitoring affordability.
5. Confirmation of Board Work Plan – Finance Committee Items (3 min)
  - a. Objective: Committee members to review and confirm items on the Board Work Plan.
6. Summary of Committee Direction (2 min)
  - a. Objective: Senior management team liaison(s) to gain alignment and summarize direction provided by the committee.



	<b>OMAHA PUBLIC POWER DISTRICT Board Policy</b>	<b>Category:</b>	Strategic Direction
	<b>Policy No. and Name:</b>  <b>SD-2: Rates</b>	<b>Monitoring Method:</b>	Finance Committee Board Report
		<b>Frequency:</b>	Annually
		<b>Resolution No.:</b>	6070 6210
<b>Date of Approval:</b>	July 16, 2015 November 16, 2017		

The Board of Directors shall establish a ~~rate target of no general rate\* increases for a 5-year period starting January 1, 2017 and ending December 31, 2021, and a~~ directional rate target of 20% below the West North Central Regional average published rates on a system average basis\*.

In implementing this rate target, OPPD shall adhere to these principles:

- Maintain fair, reasonable and non-discriminatory rates as stated in Nebraska Revised Statute § 70-655;
- Equitably assign costs across and within all customer classes;
- Monitor affordability indicators;
- Pursue rate process and structure changes to reflect the cost of energy when it is used;
- Offer flexibility and options; and
- Be simple and easy to understand.

*\*Defined in Glossary.*

## Glossary

<b>DART</b>	<i>Days Away, Restricted or Transferred:</i> The rate is calculated by multiplying the number of DART cases times 200,000 divided by the hours worked.
<b>general rate</b>	OPPD general rates service retail customers. These are rates that are charged to all residential, commercial and industrial customers. These revenues exclude charges such as connection and service charges.
<b>liquidity</b>	Total cash and unrestricted funds available to meet ongoing daily cash requirements.
<b>nationally syndicated studies</b>	National customer satisfaction studies performed by an independent third party, regardless of OPPD's interest in participating, that provide objective measures by which electric utility companies can analyze their residential and commercial customer satisfaction relative to others in the industry.
<b>PVIR</b>	<i>Preventable Vehicle Incident Rate:</i> The rate is calculated by multiplying the number of PVIR cases times 1,000,000 divided by the miles driven.
<b>stakeholders</b>	Customer-owners, employees, community leaders, media, retirees, and any other person of interest or concern regarding OPPD business matters.
<b>system average basis</b>	Total revenue billed to retail customers divided by total kWh sold to retail customers. The result is measured in cents per kWh or the average system basis.
<b>total debt service coverage</b>	Revenues less expenses divided by total annual senior and subordinate lien debt interest and principal payments.



# Reporting Item

## BOARD OF DIRECTORS

October 19, 2021

### ITEM

Sales Tax Audit Settlement Report

### PURPOSE

Report settlement in excess of \$50,000

### FACTS

- a. In May 2018, following an audit, the Nebraska Department of Revenue (NDOR) assessed the District for uncollected sales tax, interest and penalty on pole attachment revenue, in the sum of \$489,056.60 for the Audit Period 1/1/13-12/31/15. The majority of this assessment was due to a change of interpretation by NDOR of the taxability of pole attachment revenue. The District protested the assessment. In May 2019, the Legislature enacted a bill to clarify, prospectively, that pole attachment revenue is excluded from sales taxation. Management has concluded, with the advice of counsel that it is in the District's best interest to settle the audit protest.
- b. The District and NDOR have agreed to a settlement in the amount of \$228,008.56, without any admission of liability by the District. The parties have entered into a written settlement of the claim. This report to the Board is provided pursuant to Section 84-713 of the Nebraska Revised Statutes.

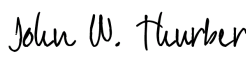
### ACTION


Reporting item

APPROVED AND RECOMMENDED FOR REPORTING TO BOARD COMMITTEE:

RECOMMENDED:

APPROVED FOR REPORTING TO BOARD:

DocuSigned by:  
  
 BA3998CC33CC4D3...  
 John W. Thurber  
 Interim Chief Financial Officer

DocuSigned by:  
  
 AC399FDCE50247E...  
 L.Javier Fernandez  
 President and Chief Executive Officer

WJT:jap



# Sales Tax Audit Resolution 2013-2015

October 19, 2021



# Issue: State assessment on Pole Attachment / Leases

- In May 2018, following an audit, the Nebraska Department of Revenue (NDOR) assessed the District for uncollected sales tax, interest and penalty on pole attachment revenue, in the sum of \$489,056.60 for the Audit Period 1/1/13-12/31/15.
- The majority of this assessment was due to a change of interpretation by NDOR of the taxability of pole attachment revenue. OPPD has been protesting this assessment.
- The District sponsored a legislative bill that was passed unanimously to exclude electric utility property from this taxation as of May 2019 (LB218).
- The NDOR refuses to waive the assessment for the 2013-2015 audit period and would also assess OPPD for 2016 and 2017. In January of 2018 OPPD began to collect sales tax on these fees from lessees after we were notified of their interpretation.

# Settlement Detail

- The original assessment by the NDOR including penalties and interest was \$489,057.
- The settlement amount of \$228,008.56 is 47% of the original amount.
- The settlement states that the NDOR will not assess the District for the 2016 and 2017 pole attachment revenues, which are yet to be audited. The estimated amount of tax that would be assessed for these years is \$293,323.
- The settlement is 29% of the original assessment plus the estimate for 2016-2017.

# Summary

- The District paid the NDOR \$228,008.56 which is 47% of the original assessment and 29% of the original assessment plus the estimated tax liability for the pre-LB218 revenue.
- This settlement prevents a lengthy legal challenge process.
- Management concluded, with the advice of counsel, that it was in the District's best interest to settle the audit protest.



**BOARD OF DIRECTORS**

October 19, 2021

ITEM

Green Power Update

PURPOSE

To provide an update on the Green Power refresh project.

FACTS

- a. OPPD project team members have conducted benchmarking and market research activities with other utilities and completed multiple outreach opportunities with current OPPD customers to identify their concerns, future wishes and values in green-sponsored products.
- b. A new customer product using customer subscribed funds focused on building “green” community initiatives will launch during the first quarter of 2022. Customers will be engaged to participate in the selection of where the funds will be used.
- c. A transparent dashboard and webpage will be developed for customers to see the quantity of funds raised and the status of active initiatives as a result.
- d. The Board will be presented with a vote as part of the 2022 Corporate Operating Plan to sunset the current state Green Power Rate Riders 463A and 463B as of March 31, 2022.

**RECOMMENDED:**

DocuSigned by:

Juli A. Comstock

Vice President – Customer Service

**APPROVED FOR REPORTING TO BOARD:**

DocuSigned by:

L. Javier Fernandez

President and Chief Executive Officer

JAC:hbs

Attachments: Presentation





# Green Power Refresh Project

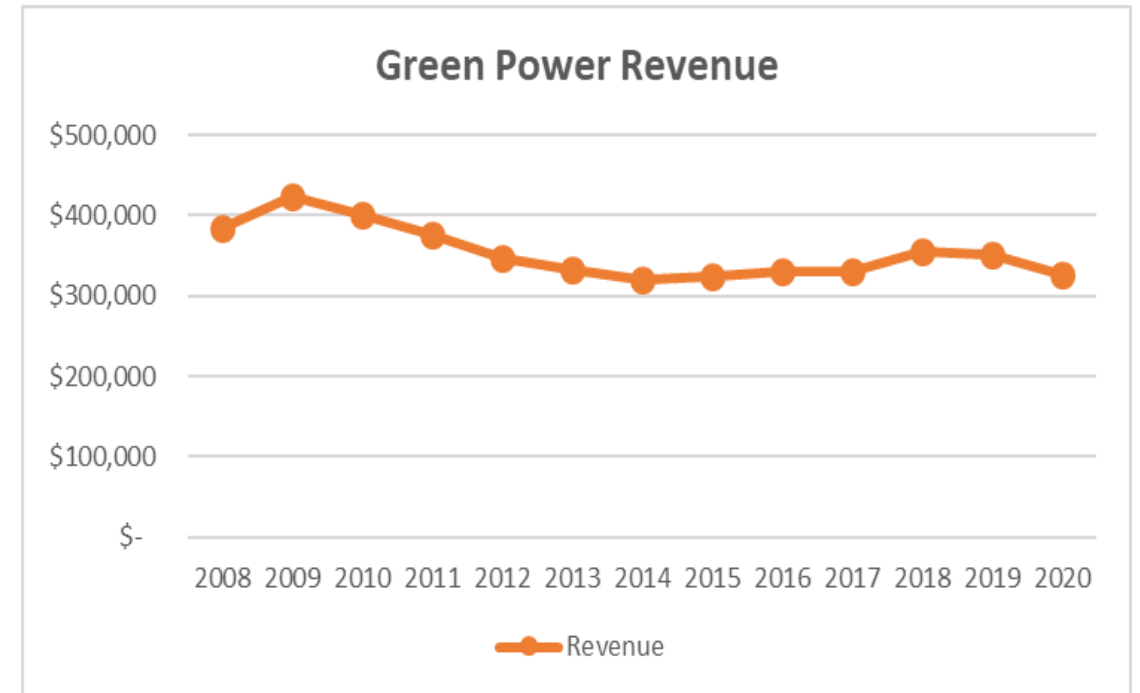
Presented to OPPD's Board of Directors

by Heather Siebken, Director of Product Development & Marketing

on October 19, 2021

# Green Power Program (Current State)

- Introduced in 2002
- Contributions supporting renewable generation projects:
  - Valley Wind Turbine
  - Elk City Landfill Gas Facility
  - Ainsworth Wind Facility
- Green Power Rate Rider
  - Funds are required to be used on generation sources that meet the Federal Energy Policy Act of 1992
- Residential participation is slightly over 1%



# Problem Statement & Goals





# Research



# Industry Research Recap

- Majority of electric utilities have some form of green energy program
- Programs have options of supporting utility renewable generation, conservation, and sustainable energy projects
- Utilities are considering phasing out their additional cost green programs due to renewable generation goals
- Separate programs for residential and commercial is most common
- Many offered shares to customers, similar to our community solar program
- Our utility research displayed top programs group several renewable products under one product name



# Customer Outreach

Existing  
Customer  
Comments

Customer  
Survey

Discussions  
with  
Community  
Organizations

Customer  
Workshop

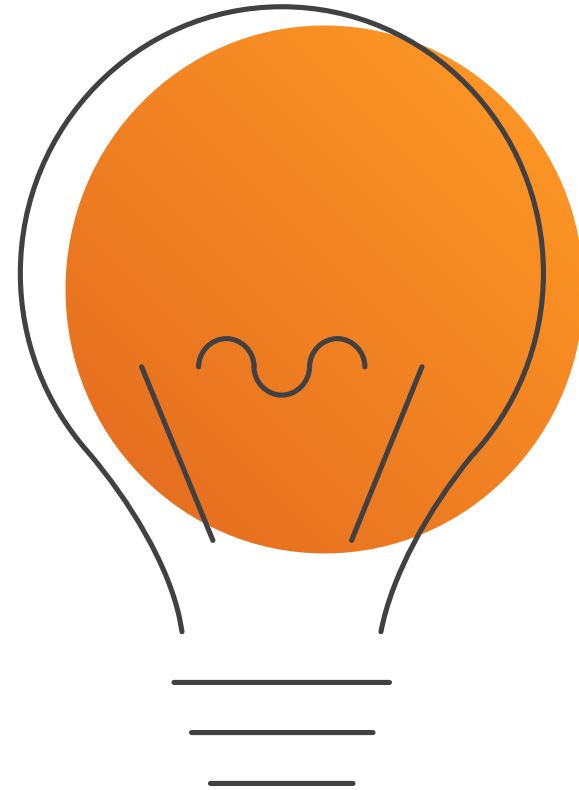
Business  
Customer  
Survey &  
Interviews

Residential  
Customer  
Power Panel  
(2)

- Understand customer values and goals
- Discuss product features, benefits and preferences
- Test product ideas to receive and incorporate feedback

# Key Customer Learnings

- OPPD to be a trusted source of information
- Funds used for community projects vs. generation
- Choice and customization features
- Community involvement and support
- Transparency of funds and project selection



*Note: Current Green Power program scored the lowest of all program options*



# Product Recommendation





# New Product Recommendation

## Product Description:

Customers subscribe to a green-focused program and partner with OPPD to choose, promote and execute on environmental projects that educates our community members and builds a healthier, safer and cleaner environment.

## Product Pricing & Participation:

- Monthly subscription (w/one-time payment campaigns)
- Price points of \$5, \$7, \$10
- Higher amount receive additional recognition and opportunity to vote on upcoming projects

## Customer Value:

- Funds go to selected green, non-OPPD generation projects within the District
- Transparent project dashboard on OPPD.com
- Marketing communication to participants showcasing projects
- Ability for communities or customer groups to apply for project funding

# Project Application Requirements

Projects must fall under 1 or more categories

## Support Sustainable Energy

Project funds new, community-based activities or initiatives in OPPD's territory that support sustainable/renewable energy

## Reduce Environmental Impact

Project is able to measure the reduction in environmental impact such as KWh, waste, gas usage, product use, etc.

## Support Community Betterment

Project shows support for education, health, culture and arts, community betterment, or social services

# Community Project Examples

- HOA or public park solar project
- Renewable generation at schools for educational purposes
- Energy efficiency projects
- Beautification, pollination & tree planting initiatives
- Low-income energy projects
- Partnerships with local organizations
- Arboretum expansion
- Sustainability park
- Bike path construction
- Support community recycling / composting
- Support metro-transit and emissions reduction
- Energy focused science/innovation fair

# Green Power vs. New Product

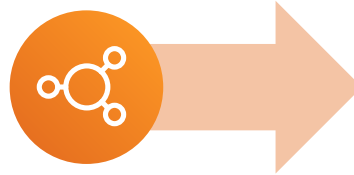
Before

Average customer enrollment over lifetime of product - 5,500

Average annual revenue over lifetime of product - \$261,000

Funds dedicated to OPPD renewable generation projects only

OPPD selected the projects, locations and generation type



After

Estimated annual enrollment at market penetration - 41,000

Estimated annual revenue at market penetration - \$2,500,000

Funds dedicated to enhancing our community in pursuit of green and renewable efforts

Community selected projects with project applications and selection committee

# Increase Customer Transparency

- Interactive tool for customers to provide feedback on projects
- Sharing success in order to cultivate transparency of funds
- Visually appealing elements, including funding gauge for various projects.
- E-Newsletter for subscribers
- Key themes, transparency and community focused

**TOGETHER  
WE CAN MAKE A  
DIFFERENCE**

# Strategic Alignment



# Next Steps

- Terms and Conditions Approval
- Project Application Scoring Criteria
- **Board Action for Rate 463A/463B**
- Customer Retention Strategy
- Brand and Message Development
- Technology Requirements
- Marketing & Communications Plan
- Launch Program in Q1, 2022
- Re-evaluate Commercial Program

# Commercial Recommendation

## Recommendation:

- Sunset current Green Power Offering and Rate Rider (463B)
- Little participation and impact

## Future State:

- Encouraged to participate in new community support product
- New project to determine future offering
  - Commercial Customer needs vary from Residential
  - Opportunity to develop product targeted at reducing or offsetting their carbon footprint





# Q&A





## Pre-Committee Agenda

SYSTEM MANAGEMENT & NUCLEAR OVERSIGHT  
PRE-COMMITTEE MEETING  
WEBEX VIDEOCONFERENCE  
October 6, 2021 4:00 – 5:00 P.M.

1. North Omaha Station Unit 4 and 5 Burner Replacement – Engineer’s Certificate (7 min)
  - a. Objective: Review proposed action item and address any questions
2. Jones Street Station Exhaust Stack Replacements – Engineer’s Certificate (7 min)
  - a. Objective: Review proposed action item and address any questions
3. SD-7: Environmental Stewardship Monitoring Report (40 min)
  - a. Objective: Review and discuss draft monitoring report and determine recommendation for the Board regarding approval
4. Confirmation of Board Work Plan – System Committee Items (3 min)
  - a. Objective: Committee members to review and confirm items on the Board Work Plan
5. Summary of Committee Direction (2 min)
  - a. Objective: Senior management team liaison(s) to summarize direction provided by the committee



# Board Action

## BOARD OF DIRECTORS

October 19, 2021

### ITEM

North Omaha Station Units 4 and 5 Gas Conversion Engineer & Procure Contract

### PURPOSE

Provide services for the design and supply of natural gas equipment and controls for North Omaha Station Units 4 and 5.

### FACTS

- a. Per Resolution No. 6006, the Board of Directors authorized management to refuel North Omaha Station Units 4 and 5 to natural gas. Testing has confirmed that modifications are required to allow Unit 5 to meet planned power output levels post fuel conversion. Updates to the controls of both Unit 4 and Unit 5 are also needed to provide for the same capability as the units have on coal.
- b. The District's engineer has certified the complex nature of the work and that use of the sealed bid process is impractical and not in the public's best interest.
- c. The District will solicit competitive proposals from qualified contractors for the work. A negotiated contract process will provide more time for potential contractors to develop a detailed work plan with optimized project schedule, pricing, and risk mitigation.
- d. The Unit 5 natural gas combustion and associated equipment are long lead delivery items. A contract for installation will be awarded separately. The installation will occur in the spring of 2024 during scheduled unit outages.

### ACTION

Approval of the Engineer's Certification and authorization for management to negotiate and enter into contracts for the design and supply of natural gas equipment and controls at the North Omaha Station for Units 4 and 5.

#### RECOMMENDED:

DocuSigned by:

*Mary J. Fisher*

C185DBBB12A4BA...

Mary J. Fisher  
Vice President – Energy Production and  
Nuclear Decommissioning

#### APPROVED FOR BOARD CONSIDERATION:

DocuSigned by:

*L. Javier Fernandez*

AC399FDCE56247E...

L. Javier Fernandez  
President and Chief Executive Officer

#### SAE

Attachments: Letter of Recommendation  
Engineer's Certificate  
Legal Opinion  
Resolution



## MEMORANDUM

**DATE:** October 6, 2021 EPND-2021-08  
**FROM:** S.A. Eidem  
**TO:** M.J. Fisher  
**SUBJECT:** North Omaha Station Units 4 and 5 Gas Conversion Engineer and procure Contract

### 1.0 GENERAL

Per Omaha Public Power District (OPPD) Board of Directors' Resolution No. 6006, North Omaha Station Unit 4 (NO4) and Unit 5 (NO5) will be refueled from coal to natural gas. Post fuel conversion, NO4 and NO5 are needed to have a combined minimum turbine generator output of 278 MW net to meet resource planning requirements. Based upon previously completed 2010 testing, NO4 can achieve the planned generation of 106 MW net on natural gas without any modifications. In July 2020, testing showed that a maximum NO5 turbine generator output of approximately 72 MW net could be achieved using only natural gas firing in the current configuration. NO5 will require burner and support system modifications to achieve the planned generation of 172 MW net on natural gas.

In March 2020, a vendor provided a high level feasibility study to convert NO5 from coal to natural gas firing and concluded the unit to be a good candidate for coal-to-natural gas conversion. Preliminary full load performance calculations predicted small changes in unit efficiency and other operating parameters, including changes in emissions that will need to be confirmed through further detailed analysis. Boiler pressure part modifications are not expected to be required for this natural gas fuel conversion to obtain the desired unit output, but will be verified as part of the proposed contract.

OPPD plans to complete detailed full thermal/hydraulic modeling of the boiler for the determination of the scope of burner and natural gas system modifications, as well as final emissions predictions. OPPD will conduct a Prevention of Significant Deterioration (PSD) netting study as well as 3rd party boiler thermal computational fluid dynamic modeling for the consideration of emission profiles. OPPD will evaluate burner/igniter dual fuel (natural gas and No. 2 fuel oil) capability and improved operational characteristics during the gas conversion contracting process to optimize unit performance. This project will also include controls automation for NO4 and NO5 to facilitate automatic generation control for these units when firing using natural gas as neither of the units are currently automated using that fuel.

## 2.0 CONTRACTING APPROACH

The District's contracting method for this project is to utilize the Engineer's Certification process for the engineer, procurement, and commissioning (material supply) contract(s) on the basis of the project being technologically complex and unique. Therefore, it is in the District's and public's best interest to forego the sealed bidding process. Instead competitive bids will be sought through a publically available Request for Proposal (RFP) and detailed negotiation process with capable bidders. The contract(s) will be awarded to the contractor with the lowest and best evaluated bid.

The process leading to the award of the engineer and procurement contract will consist of two phases; indicative bidding and short list negotiations. The District's General Counsel will be involved in the review and approval of the final contract documents. A firm price contract award is anticipated to be in the spring of 2022.

Additionally, the District will utilize a multiple contracting approach (engineer and procure contract, installation contract, controls contract, and simulator contract) with an owner's engineer and a separate boiler thermal modeling company for this project. This approach provides the necessary boiler characteristics to the burner suppliers to facilitate and establish firm prices upfront with guarantees, incentives, and liquidated damages clearly defined. It provides opportunities for design innovations that integrate engineering, materials, and construction to get the best value and optimize risk mitigation. It allows OPPD to select the most qualified material suppliers and installation companies separately and enables OPPD to work directly with the controls and simulator vendors to incorporate changes to their systems. It is anticipated that the bids from a separate labor RFP for installation of the associated equipment will be presented to the board for approval in the spring of 2023.

## 3.0 RECOMMENDATION

An Engineer's Certification of the above has been prepared. Approval of that Certification is recommended. We request the Board of Directors approve the Engineer's Certification and to authorize management to negotiate and enter into contracts to furnish and automate natural gas combustion equipment at North Omaha Station Unit 5 and to automate existing natural gas combustion equipment at North Omaha Station Unit 4.

*Scott A. Eidem*

S.A. Eidem, P.E.  
Director, Engineering Services  
Energy Production and Nuclear Decommissioning

## ENGINEER'S CERTIFICATE

Per Omaha Public Power District (OPPD) Board of Directors' Resolution to. 6006, North Omaha Station Unit Nos. 4 and 5 will be refueled to natural gas. Converting from coal to a low-nitrogen / low-sulfur content fuel such as natural gas is an effective technique for the reduction of NO<sub>x</sub> and SO<sub>x</sub> emissions. Post conversion, units 4 and 5 are planned to have a combined minimum turbine generator output of 300 megawatts (MW) or 278 MW net. Unit 5 will require burner modifications and a resultant increase of approximately 100 MW net to achieve the planned generation output levels.


OPPD intends to enter into a contract to engineer and furnish low emission combustion equipment which will allow Unit 5 to reach planned MW output levels on natural gas post fuel conversion. This contract will include automatic generation control (AGC) to automate the existing Unit 4 and 5 manual controls during natural gas operation. The replacement of the existing Unit 5 equipment requires intricate re-design to meet the required thermal and maintenance performance within physical constraints. The new design requires integration with other plant systems in order to maximize performance and sustain guarantees. For these and other reasons as explained and certified in this Engineer's Certificate, OPPD Management seeks approval from the Board of Directors to enter into the necessary contract(s) for this project without using the statutory sealed bid process.

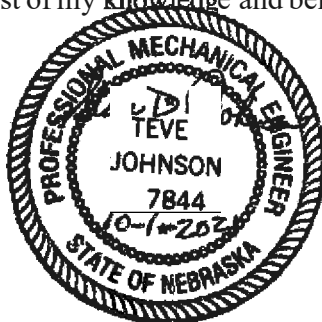
The undersigned, a Nebraska professional engineer employed by OPPD, certifies that compliance with the sealed bidding requirements of Nebraska statutes, Neb. Rev. Stat. 70-637 to 70-641, is impractical and not in the public interest for the following reasons:

- The burners, controls, and associated supporting systems are technically complex and must be integrated with other plant systems to optimize performance and obtain equipment performance guarantees.
- A wide range of potential design solutions exist with different balance of plant issues for each technology and variable cost benefits for variable unit characteristics, requiring careful discussions that cannot be conducted feasibly with sealed bidding.
- A negotiated contract provides the proper mechanism to develop terms and conditions with acceptable risk mitigation and also maintains the viability of the major burner suppliers throughout the contracting process.

Pursuant to Section 70-637 of the Nebraska Revised Statutes, as amended, the Board of Directors is requested to approve this Engineer's Certificate and authorize Management to negotiate and enter a contract to furnish and automate natural gas combustion equipment at North Omaha Station Unit 5 and to automate existing natural gas combustion equipment at North Omaha Station Unit 4 without compliance with Sections 70-637 to 74-641 of the Nebraska Revised Statutes.

I, Steve D. Johnson (registered Professional Engineer in the State of Nebraska), certify the above to be true and correct to the best of my knowledge and belief.

  
S. D. Johnson, P.E.



10-1-21  
Date



## FRASER STRYKER

PC LLO

LAWYERS

500 ENERGY PLAZA  
409 SOUTH 17TH STREET  
OMAHA, NEBRASKA 68102-2663  
TELEPHONE 402.341.6000  
TELEFAX 402.341.8290  
WWW.FRASERSTRYKER.COM

STEPHEN M. BRUCKNER  
DIRECT DIAL: 402.978.5225  
SBRUCKNER@FRASERSTRYKER.COM

September 17, 2021

Omaha Public Power District  
444 South 16th Street  
Omaha, NE 68102

RE: North Omaha Station - Engineer's Certification for North Omaha Units 4 & 5 burners, burner controls, and supporting equipment

Ladies and Gentlemen:

We have reviewed the Engineer's Certification of Steve D. Johnson, P.E., a registered professional engineer in the State of Nebraska employed by the District. Mr. Johnson's Engineer's Certification states that the District intends to enter into a contract to engineer and supply low emission combustion equipment (burners) for North Omaha Unit 5 and controls and related equipment for Units 4 and 5, in connection with the refueling of North Omaha Station to natural gas, per Board Resolution No. 6006. The Certification states that replacement of the existing Unit 5 equipment requires intricate re-design to meet the required thermal and maintenance performance within physical constraints, and requires integration with other plant systems in order to maximize performance and sustain guarantees. Mr. Johnson further certifies that a wide range of potential design solutions exist with different balance of plant issues for each technology and variable cost benefits for variable unit characteristics, requiring careful discussions with potential contractors that cannot be conducted feasibly with sealed bidding. For these and other reasons set forth in the Certification, Mr. Johnson certifies that the use of sealed bidding for this scope of work would be impractical and not in the public interest.

Section 70-637 of the Nebraska Revised Statutes authorizes the District's Board of Directors, by a two-third vote, to approve an Engineer's Certification for technologically complex or unique projects, and to authorize the District to enter into a contract to complete the project. The District is required to advertise its intention to enter into any such contract in three (3) newspapers of general circulation within the District's service area, with not less than seven (7) days between issues. The contract cannot be entered into sooner than twenty (20) days after the last advertisement.

It is our opinion that Mr. Johnson's Engineer's Certification complies with Section 70-637 and is in a form that is appropriate for approval by the District's Board of Directors. Therefore, the Board of Directors may approve the Engineer's Certification and authorize Management to negotiate and enter into the necessary contract(s) for the North Omaha Units 4 & 5 burners, burner controls, and supporting equipment. We recommend that any such contract(s) be subject to review and approval by the District's General Counsel.

Very truly yours,

A handwritten signature in blue ink, appearing to read "Stephen M. Bruckner". The signature is fluid and cursive, with a long horizontal stroke extending to the right.

Stephen M. Bruckner  
FOR THE FIRM

SMB/sac  
2611995





Williams/Fisher

**DRAFT**  
**RESOLUTION NO. 64xx**

**WHEREAS**, pursuant to Resolution No. 6006, adopted on June 19, 2014, the Board of Directors authorized management to refuel North Omaha Station Unit 4 and Unit 5 from coal to natural gas; and

**WHEREAS**, testing has confirmed that modifications are required to allow Units 4 and 5 to meet planned power output levels post fuel conversion and updates to the controls of both Units 4 and Unit 5 are needed to provide for the same capability as the units have on coal; and

**WHEREAS**, the District's Engineer has certified that the work to design and supply natural gas equipment and other controls is technically complex and the District will achieve a better result with direct negotiations with qualified Engineer, Procure and Construct (EPC) contractors; and

**WHEREAS**, for these reasons, the District's Engineer has certified that the use of sealed bidding would be impractical and not in the public interest; and

**WHEREAS**, pursuant to Nebraska Revised Statute Section 70-637 (as amended), and upon approval of the Engineer's Certification by the Board of Directors, the District may negotiate and enter into a contract or contracts related to such project without sealed bidding.

**NOW, THEREFORE, BE IT RESOLVED** by the Board of Directors of the Omaha Public Power District that:

1. The Engineer's Certification requesting that the Board waive the sealed bid requirements, in accordance with Nebraska Revised Statutes Sections 70-637 through 70-639, is hereby approved.
2. Management is hereby authorized and directed to negotiate and enter into the necessary contract or contracts to provide Engineer, Procure and Construct (EPC) services for the design and supply of natural gas equipment and controls at the North Omaha Station for Units 4 and 5, subject to review and approval of the final contract(s) by the District's General Counsel.
3. The notice required by Nebraska Revised Statutes Section 70-637 shall be published in the Omaha World Herald, or other similar newspaper of general circulation.



# Board Action

## BOARD OF DIRECTORS

October 19, 2021

### ITEM

Jones Street Station Units 1 and 2 Exhaust Stack Redesign, Material Supply and Installation Contract(s)

### PURPOSE

Provide services and materials for the redesign and installation of the exhaust stacks for Jones Street Station Units 1 and 2.

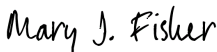
### FACTS

- a. Jones Street Station Unit 2 (JS2) is currently not in service due to damage found in the exhaust stack. A redesigned replacement exhaust stack and associated installation is required before JS2 can be available for accredited capacity in the Southwest Power Pool marketplace.
- b. Jones Street Station Unit 1 has similar damage to a lesser degree and will require the same repair scope to restore full reliable operation.
- c. The District's engineer has certified the complex nature of the work and that use of the sealed bid process is impractical and not in the public's best interest.
- d. The District will solicit competitive proposals from qualified contractors for the work. A negotiated contract process will provide potential contractors time to develop a detailed work plan with optimized design, project schedule, pricing, and risk mitigation.


### ACTION

Approval of the Engineer's Certification and authorization for management to negotiate and enter into a contract(s) for the redesign and installation of the exhaust stacks at the Jones Street Station Units 1 and 2.

#### RECOMMENDED:

DocuSigned by:  
  
 \_\_\_\_\_  
 C185DDBBB12A4BA...  
 Mary J. Fisher  
 Vice President – Energy Production and Nuclear Decommissioning

#### APPROVED FOR BOARD CONSIDERATION:

DocuSigned by:  
  
 \_\_\_\_\_  
 AC399FDCE56247E...  
 L. Javier Fernandez  
 President and Chief Executive Officer

#### SAE

- Attachments: Letter of Recommendation  
 Engineer's Certificate  
 Legal Opinion  
 Resolution



## MEMORANDUM

DATE: October 6, 2021

EPND-2021-09

FROM: S. A. Eidem

TO: M. J. Fisher

SUBJECT: Jones Street Station Units 1 and 2 Exhaust Stack Redesign and Installation Contract

### 1.00 GENERAL

In September 2021, Jones Street Station Unit 2 (JS2) exhaust stack was inspected and determined to have excessive corrosion damage preventing unit operation. JS2 was subsequently removed from availability for accredited capacity within the Southwest Power Pool integrated market until repairs can be completed. Jones Street Station Unit 1 (JS1) was subsequently inspected as extent of condition and found to have similar damage to a lesser degree. Temporary repairs are planned to be performed on JS1 to restore unit operability until permanent repairs can be implemented. OPPD resource planning indicates that firm dispatchable resources, including JS1 and JS2, will continue to provide a crucial role in supporting OPPD's system reliability going forward. The exhaust stacks for both JS1 and JS2 need to be replaced to ensure safe and reliable unit operation, resilient grid support, and continued accredited capacity credit for the OPPD generation portfolio. The cost of replacement of the exhaust stacks is significantly lower than the cost of replacing the generators.

OPPD does not have the original exhaust stack design documents and General Electric (GE), the original equipment manufacturer (OEM), has chosen to withhold the design documents due to proprietary considerations. The exhaust stacks are unique and will require detailed structural and mechanical re-design to ensure there are no adverse consequences with the operation of the units.

Compliance with the sealed bidding requirements of the Nebraska Statutes is impractical and not in the public's best interest. Contract negotiations will allow potential qualified contractors more time to develop a detailed work plan, reduce risk by having a better understanding of the project scope, maintain the overall project schedule, and preserve a competitive bid environment by reducing the chance bidders submit non-compliant bids. Negotiations will provide OPPD a better understanding and comparison of the complex bid offerings, including any performance guarantees.

Therefore, it is in the District and public's best interest to forgo the sealed bidding process. Competitive bids will be sought through a publically available Request for Proposal (RFP) and detailed negotiation process with the capable bidders. The contract will be awarded to the contractor with the lowest and best evaluated bid.

Page 2 of 2  
October 6, 2021

2.00 RECOMMENDATION

An Engineer's Certification of the above has been prepared. Approval of that Certification is recommended. We request the Board of Directors approve the Engineer's Certification and to authorize management to negotiate and enter into contract(s) to design, procure, and install new exhaust stacks for Jones Street Station Units 1 and 2.

*Scott A. Eidem*

S.A. Eidem, P.E.  
Director, Engineering Services  
Energy Production and Nuclear Decommissioning

## ENGINEER'S CERTIFICATE

The Omaha Public Power District (OPPD) intends to enter into a contract(s) to redesign and install a new exhaust stack for Jones Street Station Units 1 and 2 due to corrosion damage. Unit 2 is currently not operable and not available to provide accredited capacity within the Southwest Power Pool integrated market. Unit 1 will have temporary repairs made to restore unit operability but a permanent fix will be needed within 18 to 24 months to maintain operability.

General Electric, the original equipment manufacturer (OEM), has been consulted and a redesign of the exhaust stacks is recommended. The redesign may be done by the OEM or a third party, however, the current exhaust stack design drawings are considered proprietary by the OEM and are not available to OPPD making the redesign technologically complex in nature.

Jones Street Station Unit 2 was tested on September 8, 2021 and, after inspection, severe corrosion damage was found in the exhaust stack. Unit 1 was then inspected and similar damage was found but not as extensive as seen in Unit 2. The units are currently offline until repairs can be made on Unit 1 and a redesigned exhaust stack can be installed on Unit 2. For these and other reasons as explained and certified in this Engineer's Certificate, OPPD Management seeks approval from the Board of Directors to enter into the necessary contract(s) for this project without using the statutory sealed bid process.

The undersigned, a Nebraska professional engineer employed by OPPD, certifies that compliance with the sealed bidding requirements of Nebraska statutes, Neb. Rev. Stat. 70-637 to 70-641, is impractical and not in the public interest for the following reasons:

- The exhaust stack and associated internal components are technologically complex and must be properly designed to ensure there are no adverse consequences with the operation of the unit.
- A negotiated contract provides the proper mechanism to develop terms and conditions with acceptable risk mitigation and also maintains the viability of the major redesign suppliers throughout the contracting process.

Pursuant to Section 70-637 of the Nebraska Revised Statutes, as amended, the Board of Directors is requested to approve this Engineer's Certificate and authorize Management to negotiate and enter into contract(s) to redesign, procure, fabricate and install new exhaust stacks at Jones Street Station Units 1 and 2 without compliance with Sections 70-637 to 74-641 of the Nebraska Revised Statutes.

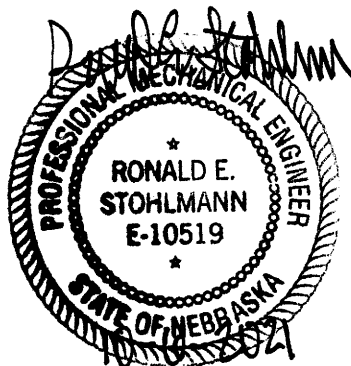
I, Ronald E. Stohlmann, (registered Professional Engineer in the State of Nebraska), certify the above to be true and correct to the best of my knowledge and belief.



R.E. Stohlmann, P.E., PMP

10-6-2021

Date





## FRASER STRYKER

PC LLO

LAWYERS

500 ENERGY PLAZA  
409 SOUTH 17TH STREET  
OMAHA, NEBRASKA 68102-2663  
TELEPHONE 402.341.6000  
TELEFAX 402.341.8290  
WWW.FRASERSTRYKER.COM

STEPHEN M. BRUCKNER  
DIRECT DIAL: 402.978.5225  
SBRUCKNER@FRASERSTRYKER.COM

October 5, 2020

Omaha Public Power District  
444 South 16th Street  
Omaha, NE 68102

RE: Jones Street Station-Redesign and replacement of Units 1 & 2 exhaust stacks

Ladies and Gentlemen:

We have reviewed the Engineer's Certification of Ronald E. Stohlmann, a registered professional engineer in the State of Nebraska employed by the District. Mr. Stohlmann's Engineer's Certification states that it is necessary for the District to enter into one or more contracts to redesign, procure, fabricate, and install new exhaust stacks for Jones Street Units 1 and 2. Unit 2 is currently offline and Unit 1 is currently offline until a temporary repair can be made to the exhaust stack. A permanent repair for both units is needed to maintain their accredited capacity within the Southwest Power Pool. Mr. Stohlmann states in the Certification that the exhaust stack and associated internal components are technologically complex and must be properly designed to ensure there are no adverse consequences with the operation of the units. He further certifies that a negotiated contract provides the proper mechanism to develop terms and conditions with acceptable risk mitigation with the available contractors.

Section 70-637 of the Nebraska Revised Statutes authorizes the District's Board of Directors, by a two-thirds vote, to approve an Engineer's Certification for technologically complex or unique projects, and to authorize the District to enter into a contract to complete the project. The District is required to advertise its intention to enter into any such contract in three (3) newspapers of general circulation within the District's service area, with not less than seven (7) days between issues. The contract cannot be entered into sooner than twenty (20) days after the last advertisement.

It is our opinion that Mr. Stohlmann's Engineer's Certification complies with § 70-637 and is in a form that is appropriate for approval by the District's Board of Directors. Therefore, the Board of Directors may approve the Engineer's Certification and authorize Management to negotiate and enter into the necessary contract(s) to redesign, procure, fabricate, and install exhaust stacks for Jones Street Station Units 1 and 2. We recommend that any such contract be subject to review and approval by the District's general counsel.

Very truly yours,

A handwritten signature in blue ink, appearing to read "Stephen M. Bruckner". The signature is fluid and cursive, with a long horizontal stroke at the end.

Stephen M. Bruckner  
FOR THE FIRM

SMB/sac  
2664197



Williams/Fisher

**DRAFT**  
**RESOLUTION NO. 64xx**

**WHEREAS**, Jones Street Station Units 1 and 2 (JS1 and JS2) require redesign and repair of the exhaust stacks on each unit; and

**WHEREAS**, the District's Engineer has certified that the work to redesign, supply, and install new exhaust stacks for JS1 and JS2 is technically complex and the District will achieve a better result with direct negotiations with qualified contractors; and

**WHEREAS**, for these reasons, the District's Engineer has certified that the use of sealed bidding would be impractical and not in the public interest; and

**WHEREAS**, pursuant to Nebraska Revised Statute Section 70-637 (as amended), and upon approval of the Engineer's Certification by the Board of Directors, the District may negotiate and enter into a contract or contracts related to such project without sealed bidding.

**NOW, THEREFORE, BE IT RESOLVED** by the Board of Directors of the Omaha Public Power District that:

1. The Engineer's Certification requesting that the Board waive the sealed bid requirements, in accordance with Nebraska Revised Statutes Sections 70-637 through 70-639, is hereby approved.
2. Management is hereby authorized and directed to negotiate and enter into the necessary contract or contracts to provide redesign, procurement of materials, fabrication, and installation services for the replacement of the exhaust stacks on Jones Street Station Units 1 and 2, subject to review and approval of the final contract(s) by the District's General Counsel.
3. The notice required by Nebraska Revised Statutes Section 70-637 shall be published in the Omaha World Herald, or other similar newspaper of general circulation.





# Board Action

## BOARD OF DIRECTORS

October 19, 2021

### ITEM

Award Request for Proposal (RFP) No. 5911 "Steel Structures"

### PURPOSE

Board of Directors authorization to award RFP No. 5911 to procure the fabrication and delivery of substation steel structures for a new substation to support load growth and reliability in the Sarpy County area.

### FACTS

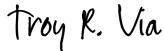
- a. Development of this substation supports load growth and reliability in the Sarpy County area.
- b. Substation steel structures support the electrical equipment within the substation.
- c. Seven (7) proposals were received; two (2) are legally and six (6) technically responsive.
- d. Substation steel structures have a desired delivery date of January 18, 2022.
- e. The proposal from Klute, Inc. was evaluated as the lowest and best bid.


### ACTION

Authorization by the Board to award RFP No. 5911 "Steel Structures" to Klute, Inc. in the amount of six hundred ninety-six thousand two hundred fifty-five dollars and 46 cents (\$696,255.46).

#### RECOMMENDED:

#### APPROVED FOR BOARD CONSIDERATION:

DocuSigned by:  
  
181167221FA24AE...  
Troy R. Via  
Vice President – Energy Delivery

DocuSigned by:  
  
AC399FDCE56247E...  
L. Javier Fernandez  
President and Chief Executive Officer

TRV:mre

Attachments: Analysis of Proposals  
Tabulation of Bids  
Legal Opinion  
Resolution



Date: October 6, 2021

From: D. D. Buelt

To: T. R. Via

RFP No. 5911  
 “Steel Structures”  
Analysis of Proposals

1.00 GENERAL

RFP No. 5911 was advertised for bid on August 17, 2021.

This contract will procure the fabrication and delivery of substation steel structures for a new substation to support load growth and reliability in the Sarpy County area.

Delivery of the substation steel structures is scheduled for January 18, 2022.

No Letters of Clarification (LOC) or Addendums were issued.

Bids were requested and opened at 2:00 p.m., C.D.T., Tuesday, September 14, 2021.

Seven (7) total proposals were received. The proposals received are summarized in the table below:

Bidder	Lump Sum Firm Price	Legally Responsive	Technically Responsive
Maxima/Metalpol	\$520,219.98	No	No
Klute, Inc.	\$696,255.46	Yes	Yes
DIS-TRAN Steel, LLC	\$723,312.00	Yes	Yes
Valmont Industries, Inc.	\$742,862.00	No	Yes
MICA Steelworks, Inc.	\$974,596.00	No	Yes
Elite Welding	\$1,134,549.00	No	Yes
Central Western Fabricators, Inc.	\$1,718,050.00	No	Yes



## 2.00 COMPLIANCE WITH CONTRACT TERMS AND GENERAL REQUIREMENTS

In the opinion of the District's legal counsel the proposal of Metalpol S.A. de C.V. ("Metalpol") is missing proof of AISC Certification. As a result, this bidder's proposal is legally non-responsive and should not receive further consideration from the District.

The proposal of Klute, Inc. includes certain commercial and technical clarifications that should be evaluated by the District.

The proposal of DIS-TRAN Steel, LLC includes certain commercial and technical clarifications that should be evaluated by the District.

The proposal of Valmont Industries, Inc. ("Valmont") incorporates Standard Terms and Conditions of Sale of the bidder which would materially increase the legal risks to be accepted by the District. As a result, this bidder's proposal is legally non-responsive and should not receive further consideration from the District.

The proposal of MICA Steelworks, Inc. ("MICA") states that its pricing is valid until October 21, 2021, instead of the required sixty (60) days after the bid opening date. As a result, this bidder's proposal is legally and commercially non-responsive and should not receive further consideration from the District.

The proposal of Elite Welding & Industrial Services ("Elite") states that its pricing is valid for sixty (60) days "excluding the purchase price of raw material(s) (Steel Tubing), due to volatile steel market." As a result, this bidder's proposal is legally and commercially non-responsive and should not receive further consideration from the District.

The proposal of Central Western Fabricators ("Central") is missing a completed and signed Proposal Form. As a result, this bidder's proposal is legally non-responsive and should not receive further consideration from the District.

Subject to the foregoing comments and the District's technical and economic evaluation, two (2) of the seven (7) proposals received in response to RFP No. 5911 may be considered by the District's Board of Directors for the award of this contract. The bond of the successful bidder also must be approved by the Board.



## MEMORANDUM

OPPDP evaluated and accepted the commercial and technical clarifications of the Klute, Inc. and DIS-TRAN Steel, LLC proposals.

### 3.00 COMPLIANCE WITH TECHNICAL REQUIREMENTS

Six (6) proposals received are technically responsive and one (1) proposal is technically non-responsive as the bid excluded AISC Certification.

### 4.00 RECOMMENDATION


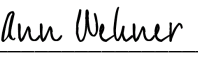
On the basis of compliance with the legal and technical requirements of the specifications, cost evaluations performed and guaranteed completion dates, it is recommended that RFP No. 5911, “Steel Structures” be awarded to Klute, Inc. in the amount of six hundred ninety-six thousand two hundred fifty-five dollars and 46 cents (\$696,255.46).



DocuSigned by:


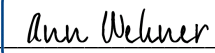
*Dannie D. Buelt*

6DD76142468B4BE...

Dannie Buelt, PE  
Director Engineering  
Energy Delivery

<p style="text-align: center;"><b>TABULATION OF BIDS</b>  <b>Opened at 2:00 p.m., C.D.T., Tuesday,</b>  <b>September 14, 2021, in Omaha, Nebraska</b></p> <hr/> <p style="text-align: center;"><b>Anticipated Award Date</b>  <b>October 21, 2021</b></p> <hr/> <p style="text-align: center;"><b>ENGINEER'S ESTIMATE</b></p> <p style="text-align: center;"><b>\$1,090,228.00</b></p>	<p><b>REQUEST FOR PROPOSAL NO. 5911</b>  <b>Steel Structures</b></p> <p style="text-align: right;">Page 1 of 3</p>			<p>DocuSigned by:    <small>9426AD61477A435</small>  <b>Director</b></p> <p>DocuSigned by:    <small>F385A3C97DAD458</small>  <b>Supply Chain Management</b>  <b>Complied by and Certified Correct</b></p>
<p><b>BID ITEM</b></p>	<p><b>BIDDER'S NAME &amp; ADDRESS</b></p>			
	<p><b>Central Western Fabricators, Inc.</b>  <b>400 W 2nd Street</b>  <b>Atlantic, IA 50022</b></p>	<p><b>DIS-TRAN Steel, LLC</b>  <b>4725 Hwy 28 East</b>  <b>Pineville, LA 71360</b></p>	<p><b>Elite Welding</b>  <b>279 Kefauver Road</b>  <b>Millwood, KY 42762</b></p>	
<p><b>1. <u>Price Proposal:</u></b>  <b>161kV Substation Steel Bus Structures</b></p> <p><b>Combined Lump Sum of Extended Unit Prices for</b>  <b>Items 1 to 15 in Attachment A.</b></p> <p><b>2. <u>Delivery Guarantee(s):</u></b></p> <p><b>Desired Delivery Date: January 18, 2022</b></p>	<p><b>SUPPLIER'S BID</b></p> <p><u>\$1,718,050.00</u></p> <p><b><u>Guaranteed Delivery Date</u></b></p> <p><u>January 11, 2022</u></p>	<p><b>SUPPLIER'S BID</b></p> <p><u>\$723,312.00</u></p> <p><b><u>Guaranteed Delivery Date</u></b></p> <p><u>12 Weeks ARO and Final Information</u></p>	<p><b>SUPPLIER'S BID</b></p> <p><u>\$1,134,549.00</u></p> <p><b><u>Guaranteed Delivery Date</u></b></p> <p><u>February 1, 2022</u></p>	

<p align="center"><b>TABULATION OF BIDS</b>                  Opened at 2:00 p.m., C.D.T., Tuesday,                  September 14, 2021, in Omaha, Nebraska</p>	<p align="center"><b>REQUEST FOR PROPOSAL NO. 5911</b>  <b>Steel Structures</b></p> <p align="right">Page 2 of 3</p>			<p>DocuSigned by:                    9426AD614770435  <b>Director</b></p> <p>DocuSigned by:                    F8B5A3697DAD4F8  <b>Supply Chain Management</b>                  Compiled by and Certified Correct</p>
<p align="center">Anticipated Award Date                  October 21, 2021</p>				
<p align="center"><b>ENGINEER'S ESTIMATE</b></p> <p align="center">\$1,090,228.00</p>				
<p align="center"><b>BID ITEM</b></p>	<p align="center"><b>BIDDER'S NAME &amp; ADDRESS</b></p>			
	<p align="center">Klute Inc.                  1313 Road G                  York, NE 68467</p>	<p align="center">Maxima/Metapol                  Santiago Papasquiario 158                  Gomez Palacio Dgo. Mex, 35079</p>	<p align="center">MICA Steelworks, Inc.                  P.O. Box 161999                  Fort Worth, TX 76161</p>	
<p><b>1. Price Proposal:</b>                  161kV Substation Steel Bus Structures</p> <p>Combined Lump Sum of Extended Unit Prices for                  Items 1 to 15 in Attachment A.</p> <p><b>2. Delivery Guarantee:</b></p> <p>Desired Delivery Date: January 18, 2022</p>	<p align="center"><b>SUPPLIER'S BID</b></p> <p align="center">\$696,255.46</p> <p align="center"><u>Guaranteed Delivery Date</u></p> <p align="center"><u>January 18, 2022</u></p>	<p align="center"><b>SUPPLIER'S BID</b></p> <p align="center">\$520,219.98</p> <p align="center"><u>Guaranteed Delivery Date</u></p> <p align="center"><u>December 17, 2021</u></p>	<p align="center"><b>SUPPLIER'S BID</b></p> <p align="center">\$974,596.00</p> <p align="center"><u>Guaranteed Delivery Date</u></p> <p align="center"><u>20 - 22 Weeks ARO</u></p>	

<p style="text-align: center;"><b>TABULATION OF BIDS</b>                  Opened at 2:00 p.m., C.D.T., Tuesday,                  September 14, 2021, in Omaha, Nebraska</p> <hr/> <p style="text-align: center;">Anticipated Award Date                  October 21, 2021</p> <hr/> <p style="text-align: center;"><b>ENGINEER'S ESTIMATE</b></p> <p style="text-align: center;">\$1,090,228.00</p>	<p><b>REQUEST FOR PROPOSAL NO. 5911</b>  <b>Steel Structures</b></p> <p style="text-align: right;">Page 3 of 3</p>		<p>DocuSigned by:                    9426AD61477A85F5  <b>Director</b></p> <p>DocuSigned by:                    E8B578097DAD4188C  <b>Supply Chain Management</b>                  Compiled by and Certified Correct</p>
<p style="text-align: center;"><b>BID ITEM</b></p>	<b>BIDDER'S NAME &amp; ADDRESS</b>		
	<p><b>Valmont Industries, Inc.</b>                  28800 Ida Street                  Valley, NE 68064</p>		
<p><b>1. Price Proposal:</b>                  161kV Substation Steel Bus Structures</p> <p>Combined Lump Sum of Extended Unit Prices for                  Items 1 to 15 in Attachment A.</p> <p><b>2. Delivery Guarantee:</b></p> <p>Desired Delivery Date: January 18, 2022</p>	<p><b>SUPPLIER'S BID</b></p> <p>\$742,862.00</p> <p><b>Guaranteed Delivery Date</b></p> <p><u>16 - 20 Weeks ARO and Approved Designs</u></p>	<p><b>SUPPLIER'S BID</b></p> <p>\$ _____</p> <p><b>Guaranteed Delivery Date</b></p>	<p><b>SUPPLIER'S BID</b></p> <p>\$ _____</p> <p><b>Guaranteed Delivery Date</b></p>

# FRASER STRYKER

PC LLO

LAWYERS

500 ENERGY PLAZA  
409 SOUTH 17TH STREET  
OMAHA, NEBRASKA 68102-2663  
TELEPHONE 402.341.6000  
FAX 402.341.8290  
WWW.FRASERSTRYKER.COM

TROY F. MEYERSON  
DIRECT DIAL: 402.978.5347  
TMEYERSON@FRASERSTRYKER.COM

October 1, 2021

Omaha Public Power District  
444 South 16<sup>th</sup> Street  
Omaha, NE 68102

RE: Request for Proposal No. 5911 — Steel Structures ("RFP No. 5911")

Ladies and Gentlemen:

We have reviewed the seven (7) proposals received in response to RFP No. 5911 and provide the following opinion.

The proposal of Valmont Industries, Inc. ("Valmont") incorporates Standard Terms and Conditions of Sale of the bidder which would materially increase the legal risks to be accepted by the District. As a result, this bidder's proposal is legally non-responsive and should not receive further consideration from the District.

The proposal of Central Western Fabricators ("Central") is missing a completed and signed Proposal Form. As a result, this bidder's proposal is legally non-responsive and should not receive further consideration from the District.

The proposal of Elite Welding & Industrial Services ("Elite") states that its pricing is valid for sixty (60) days "excluding the purchase price of raw material(s) (Steel Tubing), due to volatile steel market." As a result, this bidder's proposal is legally and commercially non-responsive and should not receive further consideration from the District.

The proposal of MICA Steelworks, Inc. ("MICA") states that its pricing is valid until October 21, 2021, instead of the required sixty (60) days after the bid opening date. As a result, this bidder's proposal is legally and commercially non-responsive and should not receive further consideration from the District.

The proposal of DIS-TRAN Steel, LLC includes certain commercial and technical clarifications that should be evaluated by the District.

The proposal of Klute Inc. includes certain commercial and technical clarifications that should be evaluated by the District.



Omaha Public Power District

October 1, 2021

Page 2

The proposal of Metalpol S.A. de C.V. ("Metalpol") is missing proof of AISC Certification. As a result, this bidder's proposal is legally non-responsive and should not receive further consideration from the District.

Subject to the foregoing comments and the District's technical and economic evaluation, two (2) of the seven (7) proposals received in response to RFP No. 5911 may be considered by the District's Board of Directors for the award of this contract. The bond of the successful bidder also must be approved by the Board.

Very truly yours,



Troy F. Meyerson  
FOR THE FIRM

2662124.01



Williams/Via

**DRAFT**  
**RESOLUTION NO. 64xx**

**WHEREAS**, sealed bids were requested and advertised, as required by law, for the following:

**REQUEST FOR PROPOSAL (RFP) NO. 5911**  
**STEEL STRUCTURES**

**WHEREAS**, bids were received and opened at the time and place mentioned in the published notices and the Director – Supply Chain Management supervised the tabulations, which have been submitted to this Board; and

**WHEREAS**, the Board of Directors has carefully considered the bids submitted, as well as the recommendations of the District's Management and General Counsel.

**NOW, THEREFORE, BE IT RESOLVED** by the Board of Directors of the Omaha Public Power District that the proposal of Klute, Inc. in the amount of \$696,255.46 to furnish and deliver substation steel structures pursuant to Request for Proposal No. 5911 is hereby accepted, and the form of payment and performance bond of such bidder is approved.

# 161kV Substation Steel Structures





**BOARD OF DIRECTORS**

October 19, 2021

ITEM

Nuclear Oversight Committee Report

PURPOSE

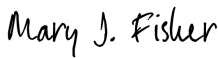
The Nuclear Oversight Committee provides a regular oversight of items related to the Fort Calhoun Station (FCS) nuclear plant.

FACTS

In addition to safe and secure dry cask storage of fuel, the required Preventative Maintenance tasks and Surveillance Tests, the following major decommissioning activities were conducted:

- Additional reactor vessel internal segmentation equipment has been received and moved into containment. Completed staging equipment in the cavity that was required prior to filling the cavity with water. The removal of the reactor head and filling of the cavity will take place in the near future in preparation to begin segmentation.
- The foundation and slab for the containment waste structure are complete which allows construction of the temporary building and lifting system to commence. The structure and associated equipment will be primarily utilized to safely move out the materials removed from the vessel and the bulk of containment.
- Leaders from OPPD and EnergySolutions met with NRC Region IV leadership during a drop-in visit at their offices in Arlington, Texas. The trip was planned as part of the routine update on decommissioning performance. The topics included, for example, major activities completed, upcoming activities, and overall project performance similar to this month's update to the Board.

**RECOMMENDED:**

DocuSigned by:  
  
C185DD88812A4BA...  
Mary J. Fisher  
Vice President – Energy Production  
and Nuclear Decommissioning

**APPROVED FOR REPORTING TO BOARD:**

DocuSigned by:  
  
AC200FDGE56247E...  
L. Javier Fernandez  
President and CEO

MJF:tsu

# Fort Calhoun Station Decommissioning Update October 2021

Tim Uehling – Senior Director FCS Decommissioning

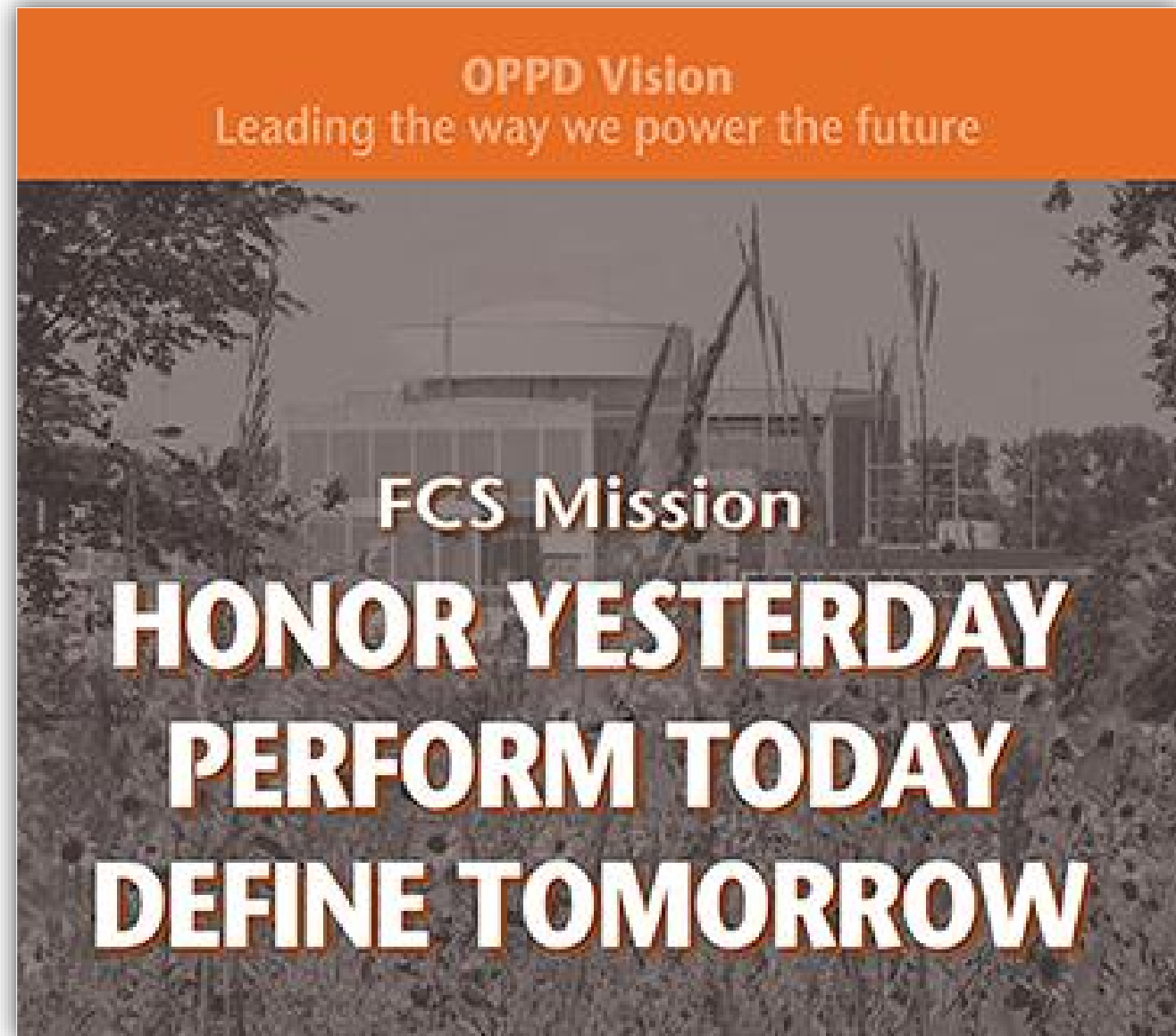




**OPPD**  
Omaha Public Power District  
08/20/2021

# Agenda

- Major accomplishments
- Future activities preview
- Performance Challenges  
& Opportunities
- Questions

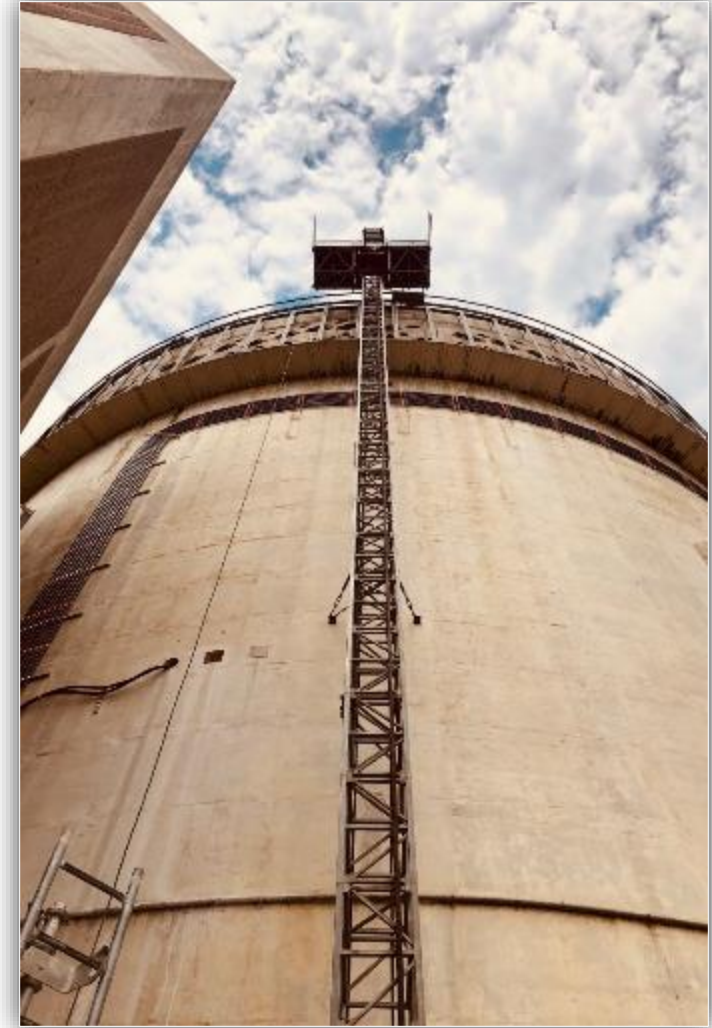


# Future Activities Timeline (\*slide from Oct. 2020 Board presentation)

## By the end of 2021

- Containment ready for RVI\* work
- RVI segmentation equipment on-site
- Rail & waste processing facility operational
- Several clean building demos complete
- License Termination Plan submitted to NRC
- Improve safety performance

\*RVI = Reactor Vessel Internal



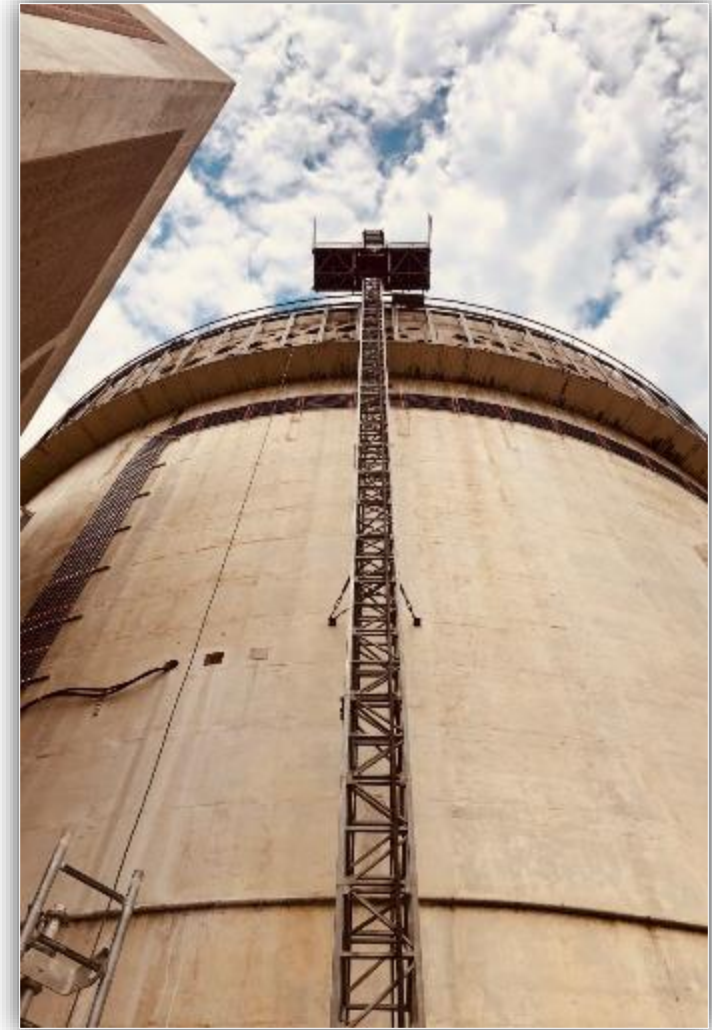


# Future Activities Timeline (\*slide from Oct. 2020 Board presentation)

## By the end of 2021

- Containment ready for RVI\* work
- RVI segmentation equipment on site
- Rail & waste processing facility operational
- Several clean building demos complete
- License Termination Plan submitted to NRC
- Improve safety performance

\*RVI = Reactor Vessel Internal



# Safety Performance

- Continued safe, secure storage of spent nuclear fuel
- No challenges to nuclear or radiological safety
- No challenges to environmental safety
- No OPPD employee DART injuries since 2018



# Preparing for RVI Equipment Move-In



# Preparing Containment for RVI



# RVI Equipment On-Site



# Rail & Waste Processing Facility Operational



# Warehouse Demolition



# Chemistry & Maintenance Building Demolition





# Security Building Demolition



# License Termination Plan Submitted

OCA: Owner  
Controlled Area

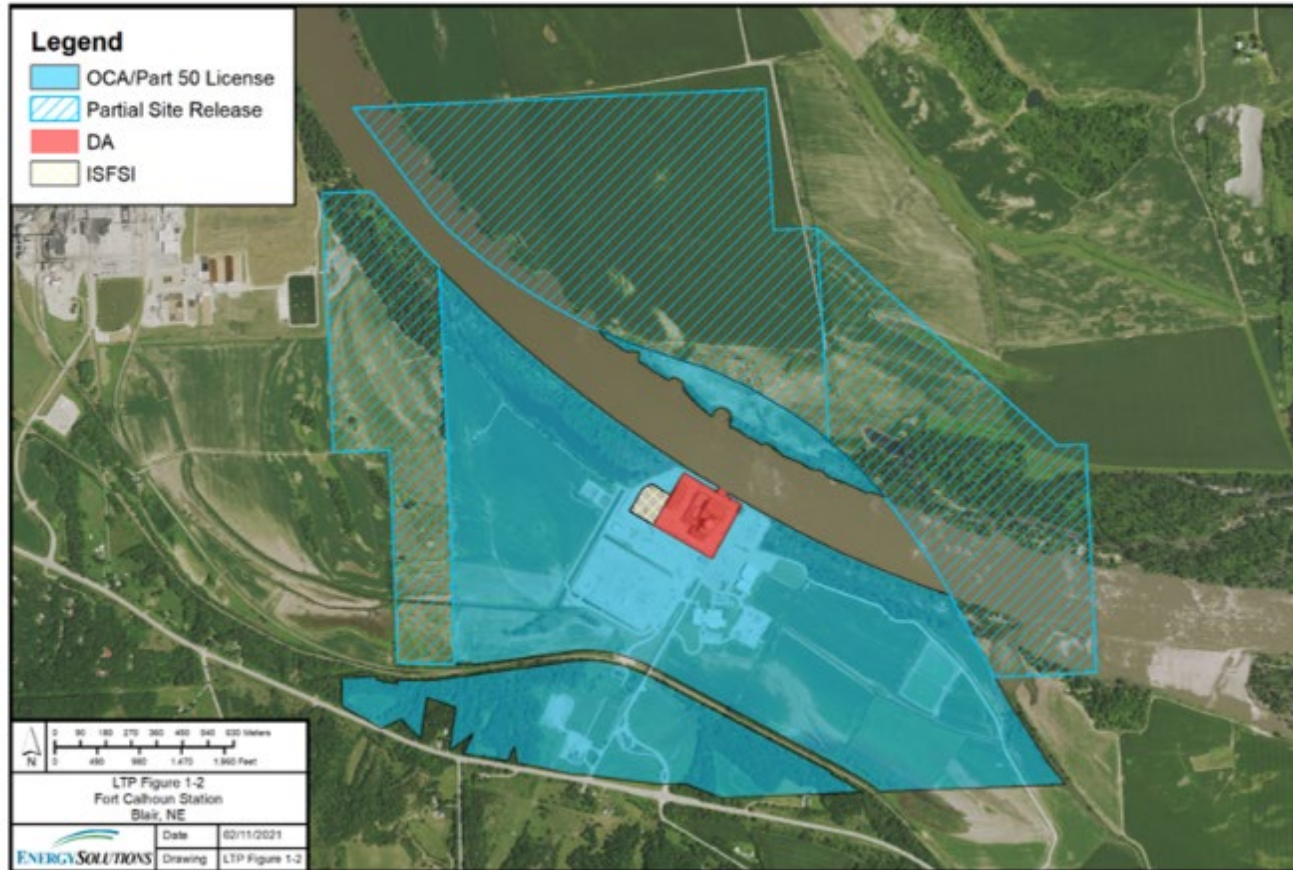
DA: Deconstruction  
Area

ISFSI: Independent  
Spent Fuel Storage  
Installation

FORT CALHOUN STATION DECOMMISSIONING PROJECT  
LICENSE TERMINATION PLAN  
REVISION 0

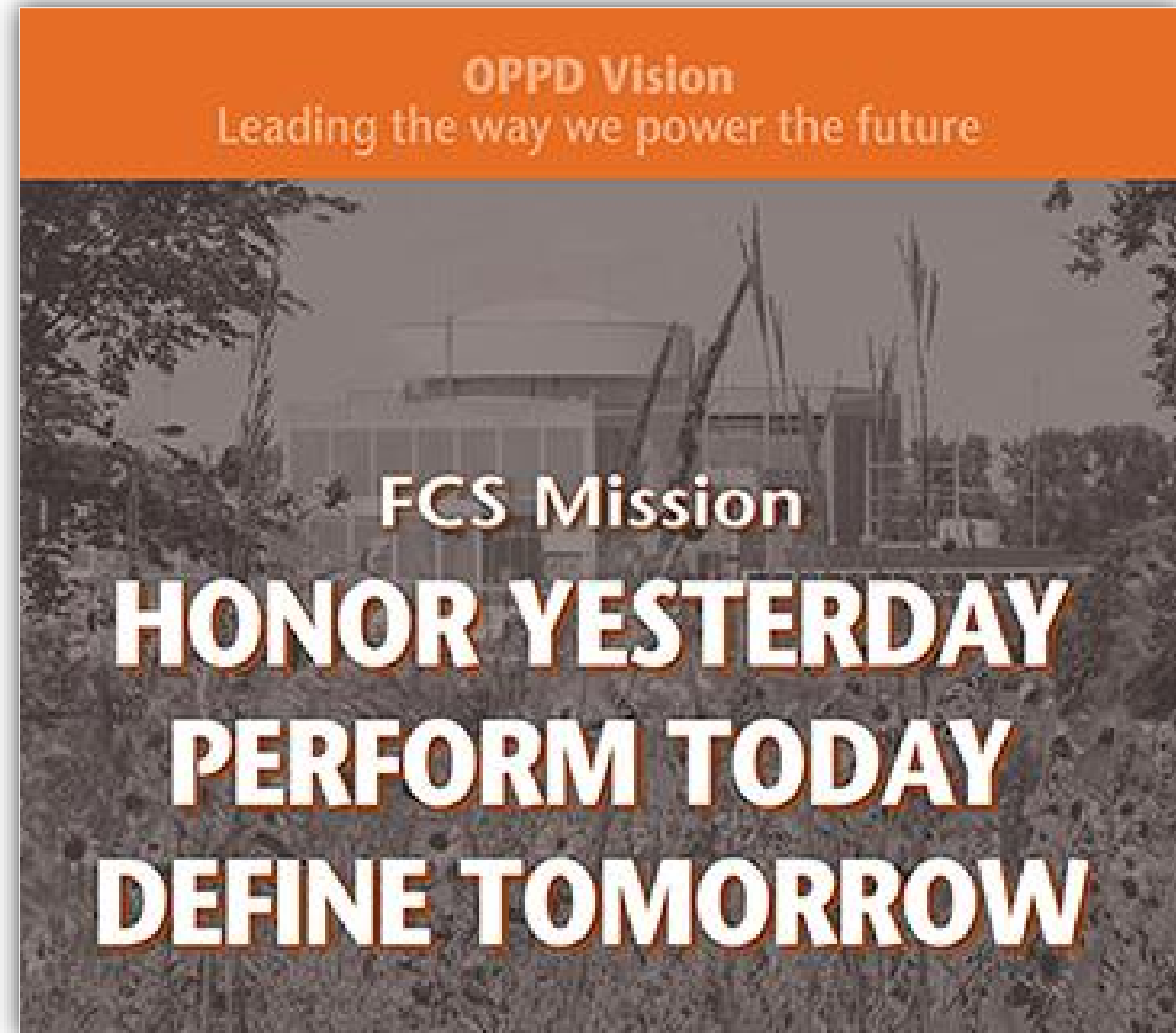


Figure 1-2 FCS Owner Controlled Areas

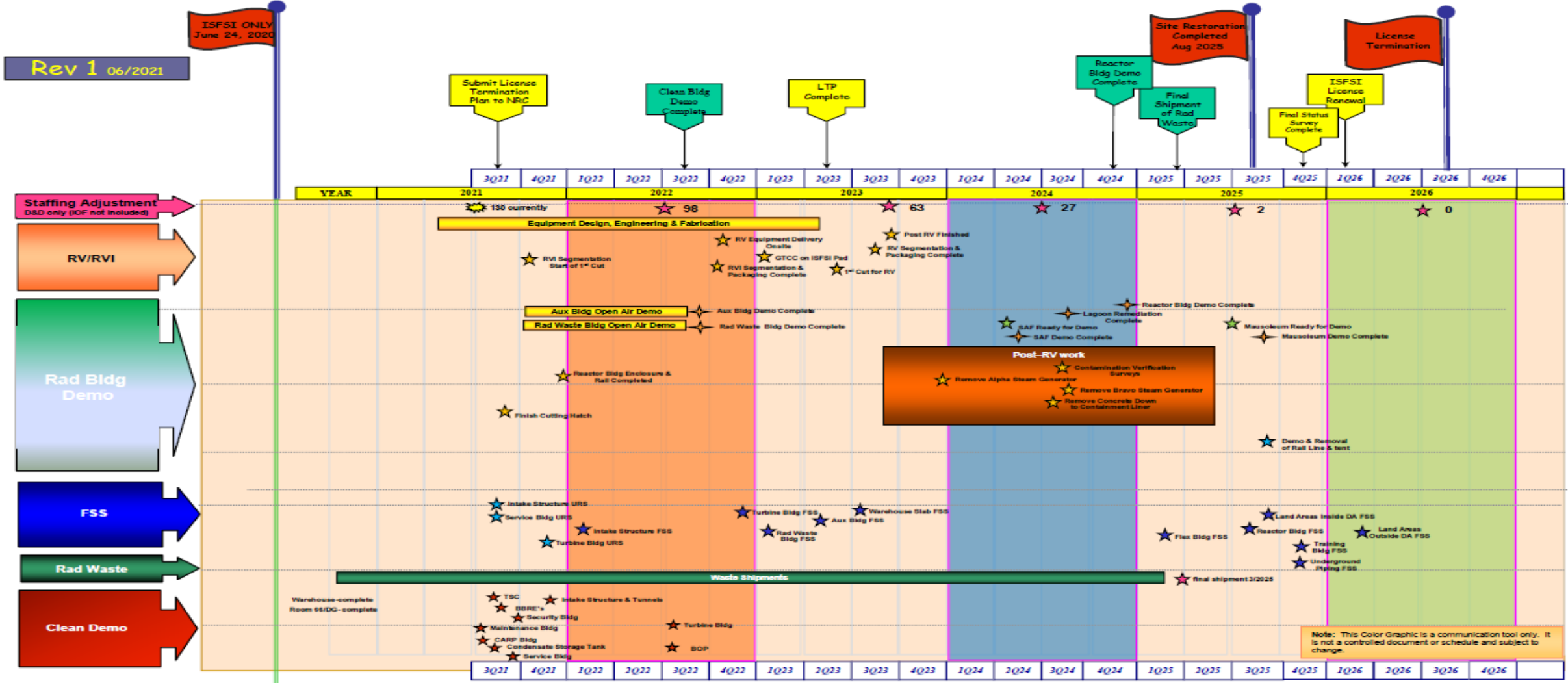


# Agenda

- Major accomplishments
- Future activities preview
- Performance Challenges & Opportunities
- Questions



# Fort Calhoun DECON Timeline



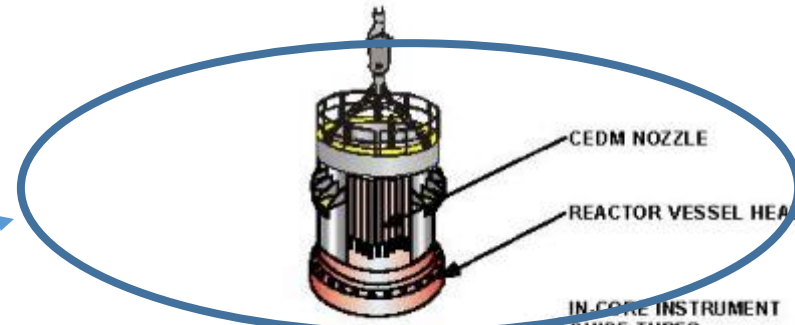
# Future Activities Timeline

- Turbine building demo complete: 3Q2022
- Auxiliary building demo complete: 4Q2022\*
- RVI segmentation complete: 1Q2023
- Reactor vessel segmentation complete: 3Q2023
- Containment equipment removed: 4Q2024
- Containment demo complete: 3Q2025
- Substantially complete: 4Q2025
- Final Status Survey complete: 4Q2025
- License termination: ~4Q2026

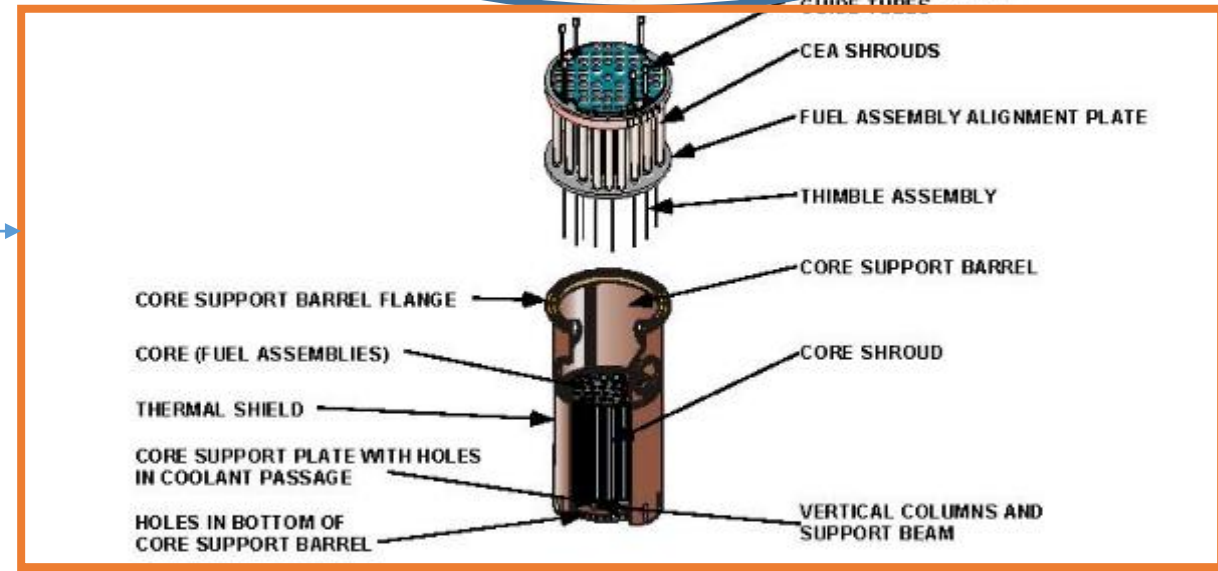
\*Note: date improved over original plan (opportunity to gain margin)

# Segmentation

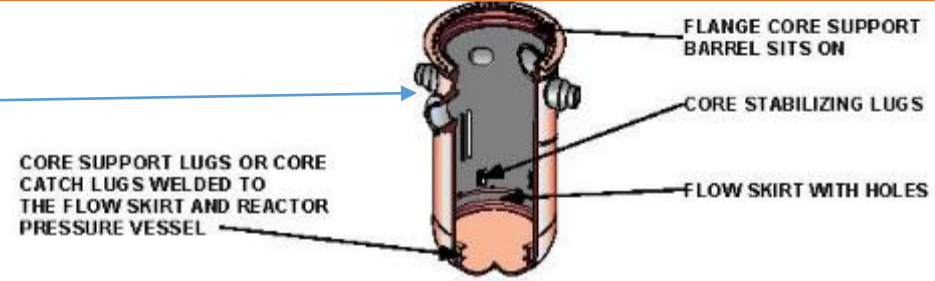
Reactor Head & Seismic Skirt



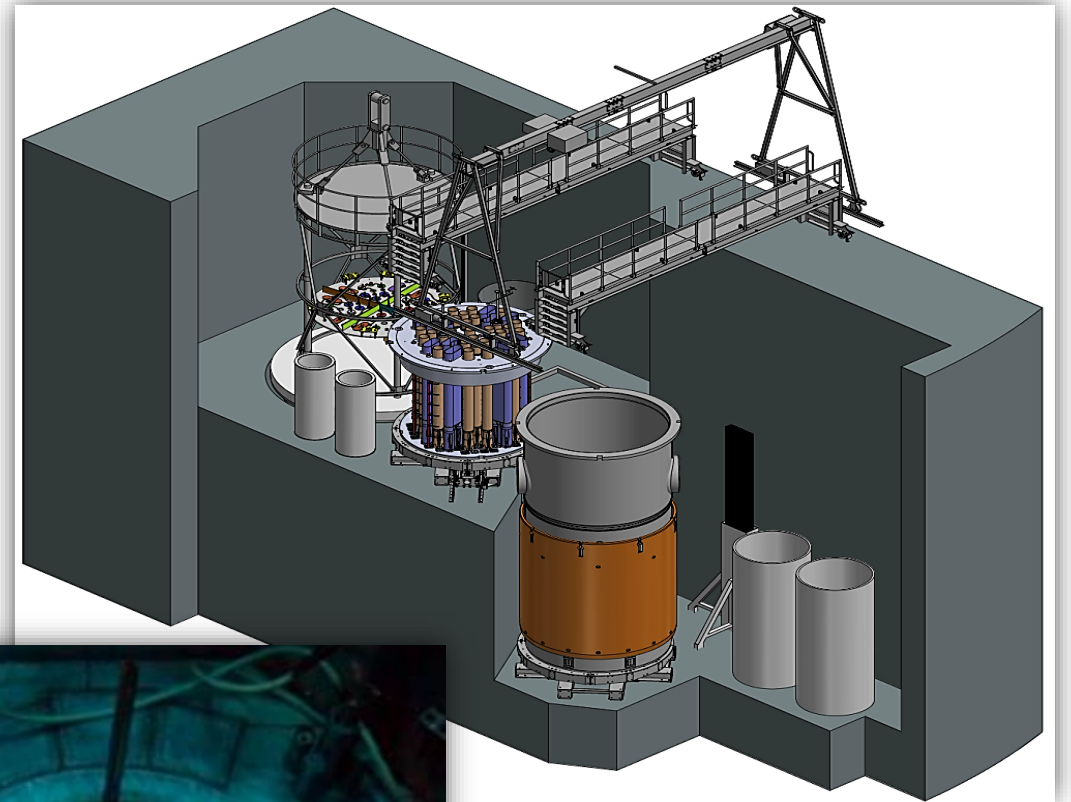
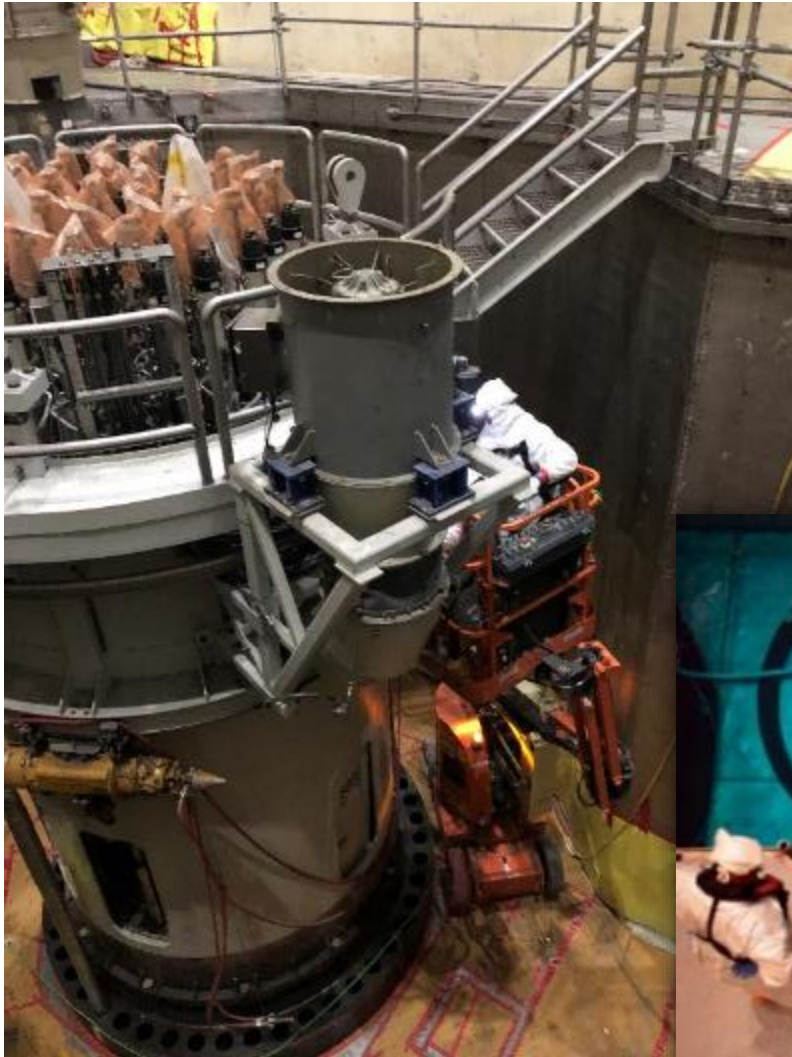
Reactor Vessel Internals



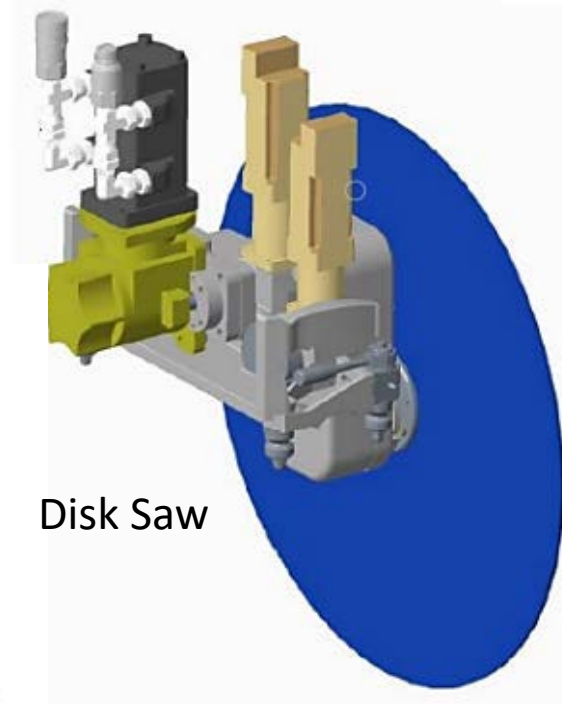
Reactor Vessel



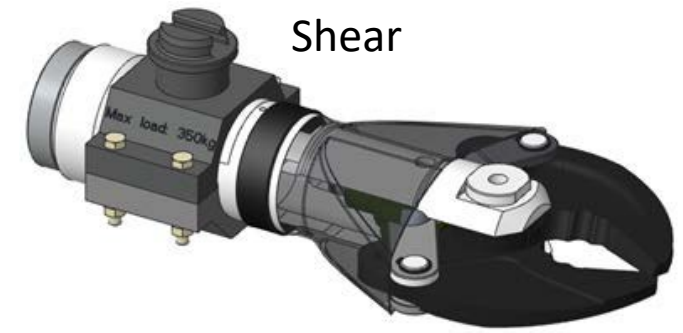
# RVI Segmentation



# RVI Segmentation



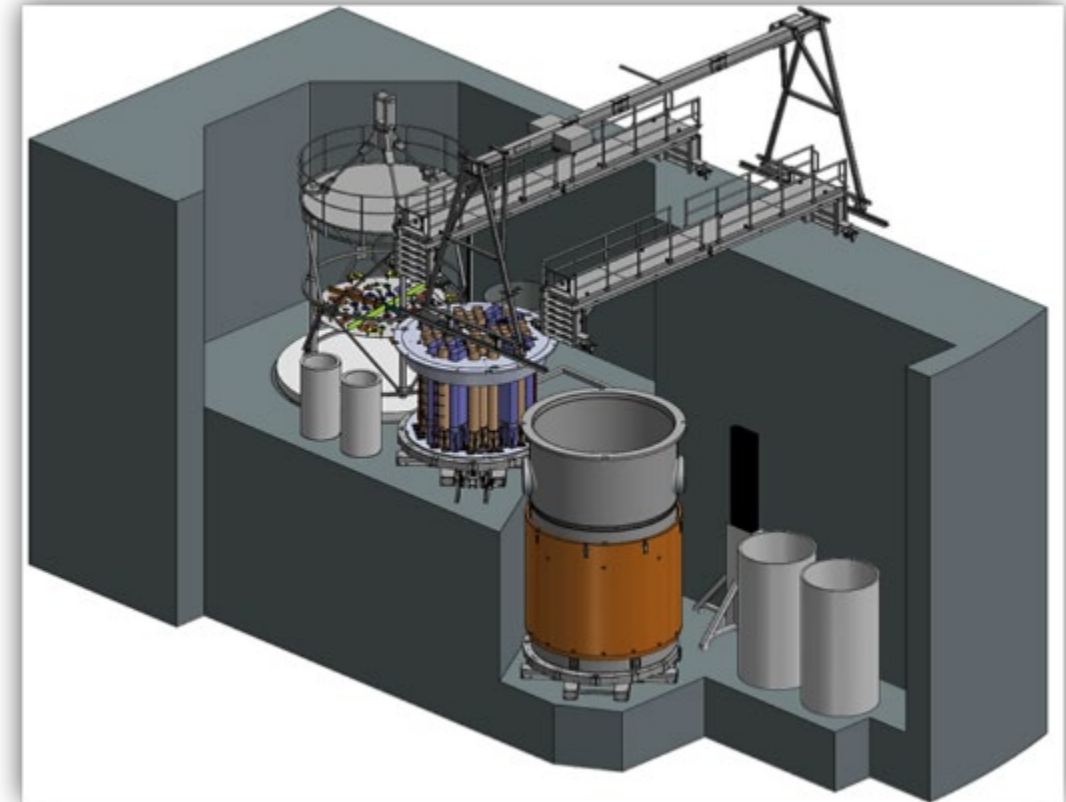
Disk Saw



Shear

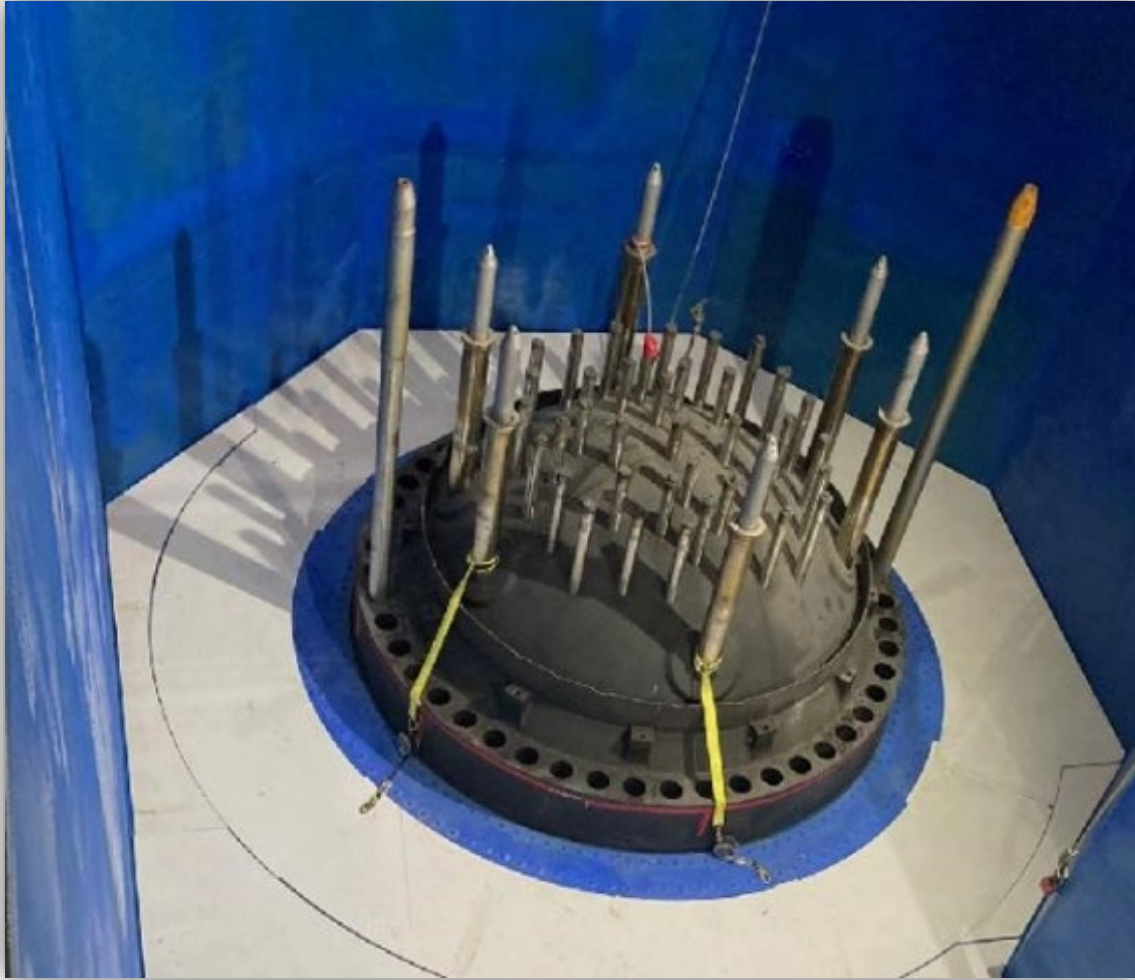


Band Saw &  
Turntable





# RVI Segmentation



# RVI Segmentation

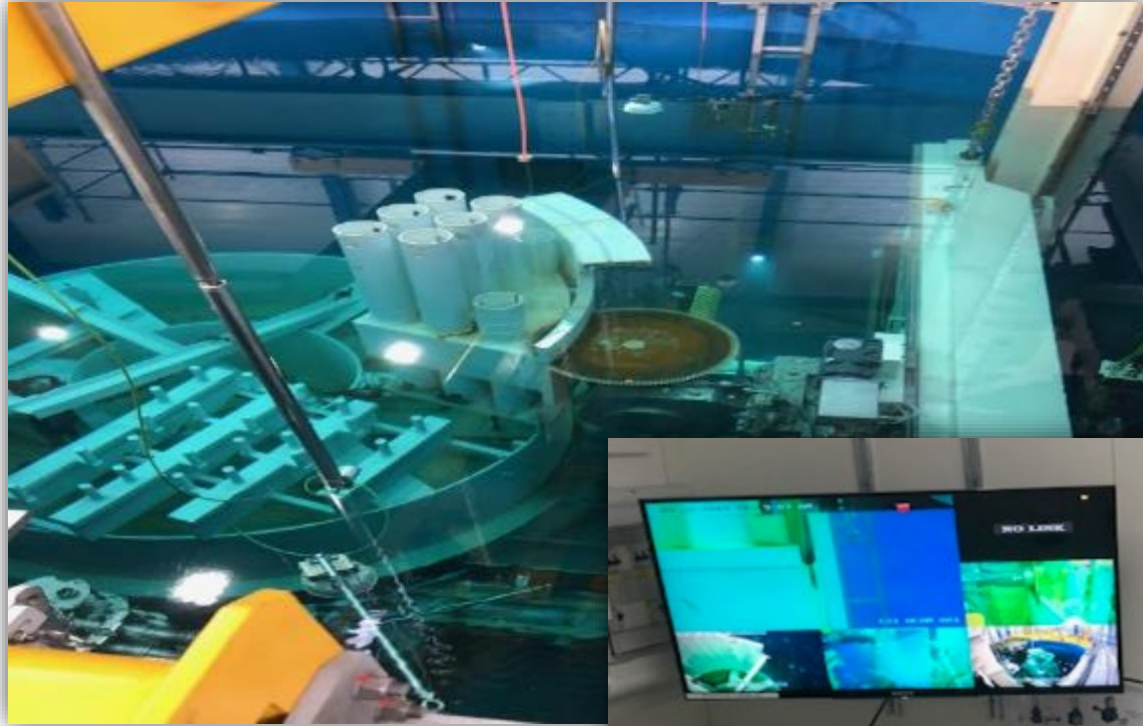
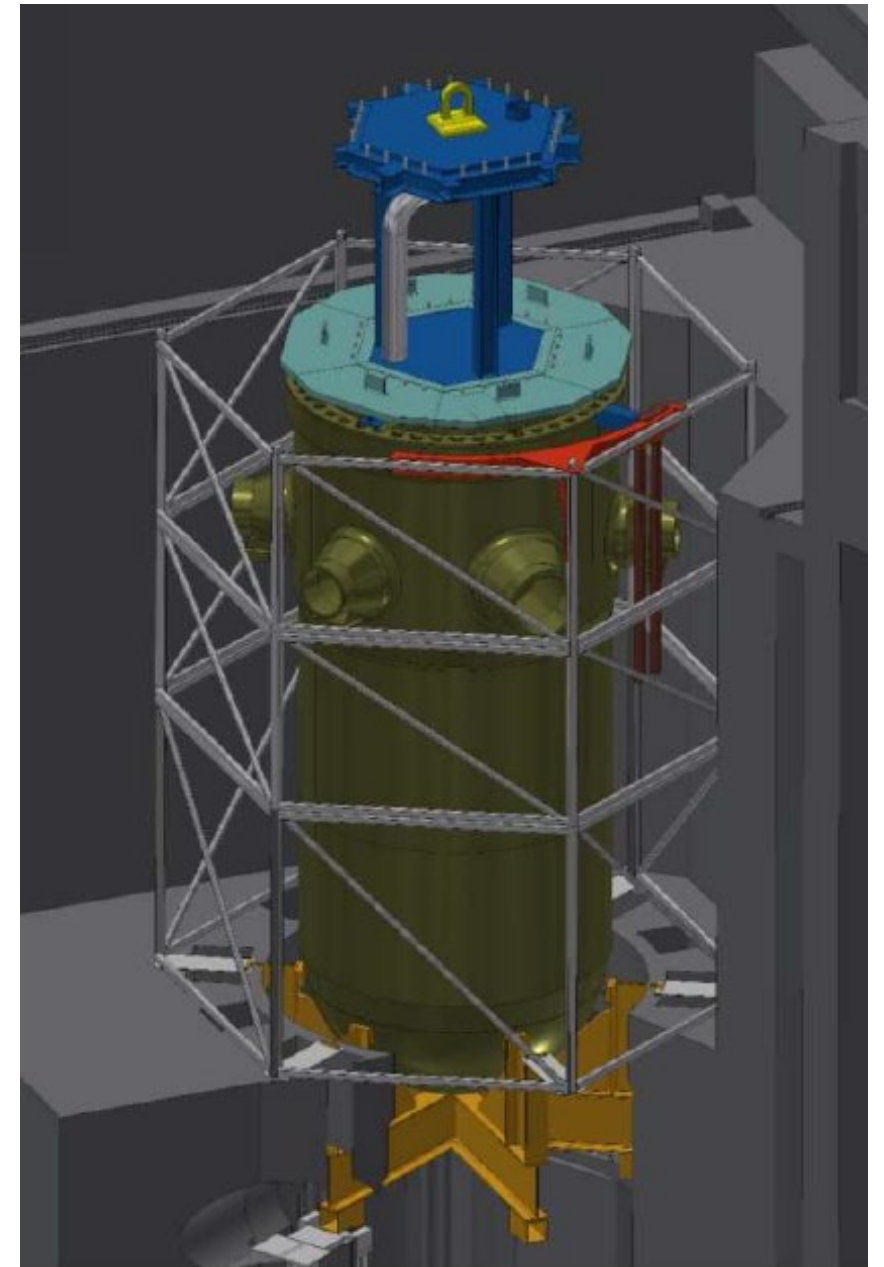
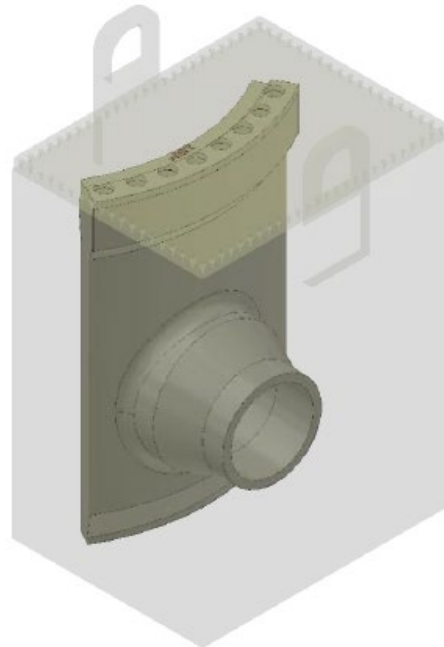
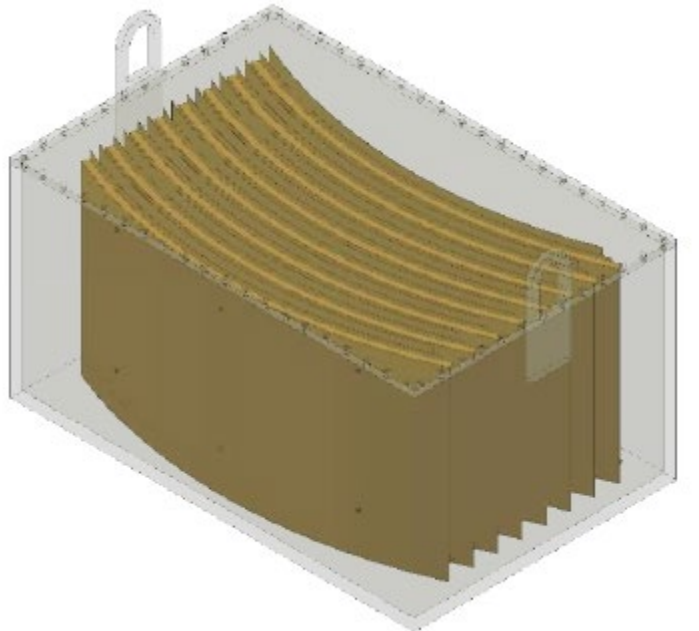
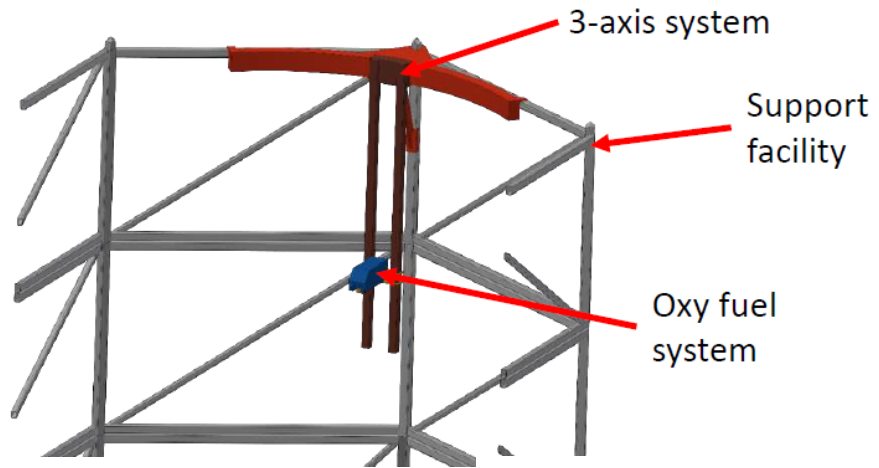


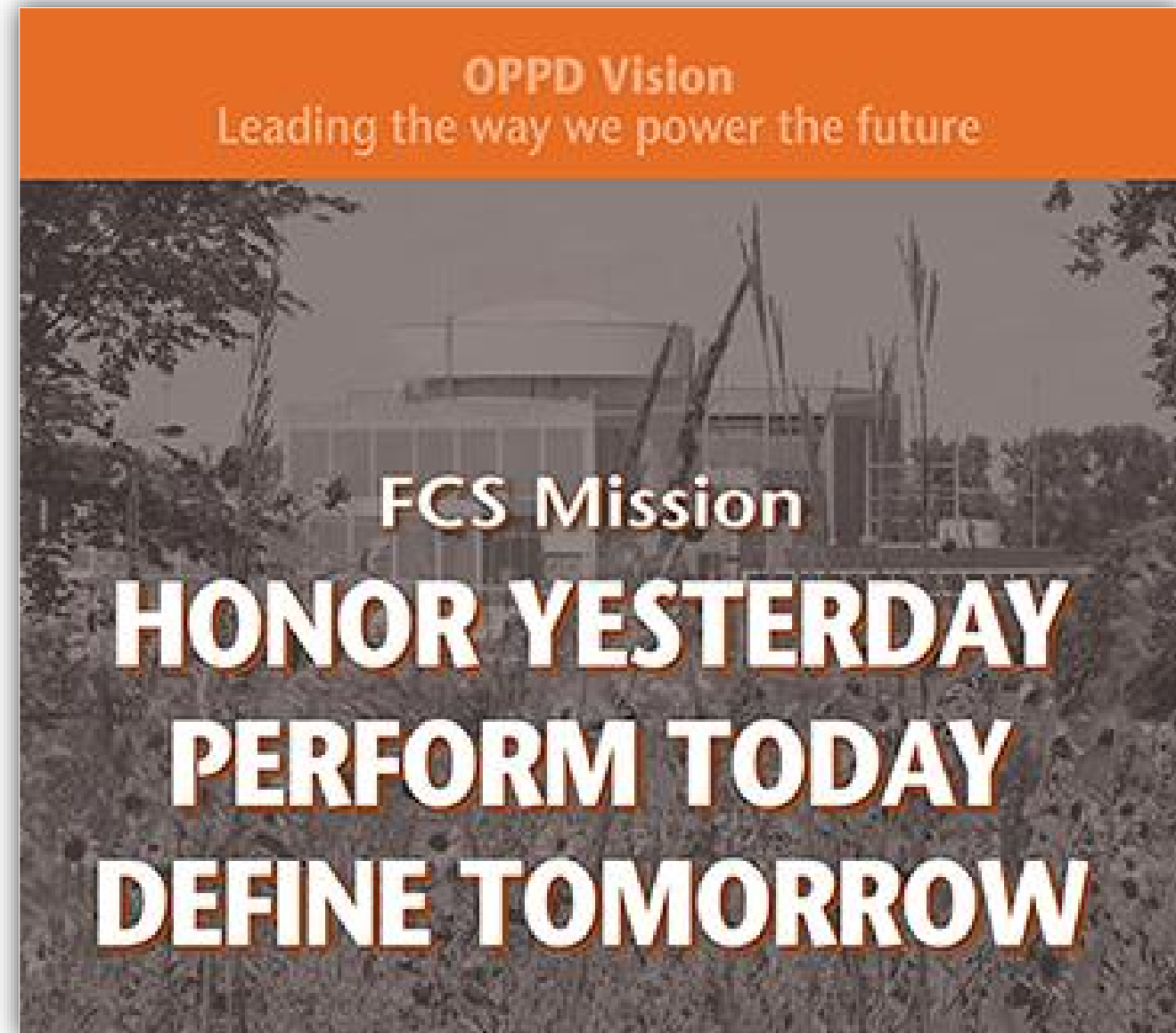
Illustration Only –  
Not the FCS specific system

# RV Segmentation



# Agenda

- Major accomplishments
- Future activities preview
- Performance Challenges & Opportunities
- Questions

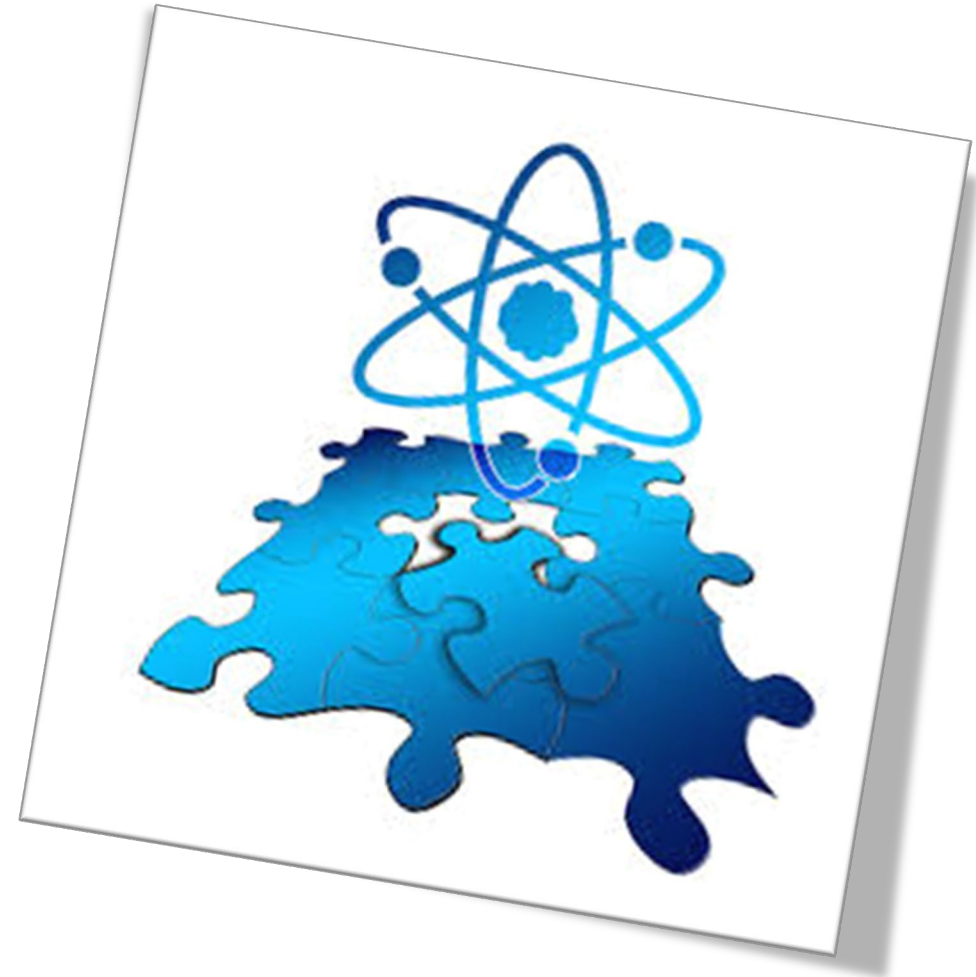


# Performance Challenge

Decommissioning is a complex, dynamic project made up of numerous interrelated & interdependent sub-projects

Ebbs and flows in schedule and cost performance against the original schedule are expected and continue to occur based on these challenges

Not every individual project comes in on-time and on-budget with the initial estimate



# Complexity & Coordination Illustration



# Continuous Improvement Opportunity

- Despite the complex challenges, overall project substantial completion is targeted by the end of 2025, with our financial estimate at completion on track with the planned budget
- Our opportunity is to further refine individual project scopes, schedules, costs, and critical interfaces between projects to maximize safe, efficient deconstruction while continuing to meet environmental and regulatory commitments



Other Questions...





# Board Action

## BOARD OF DIRECTORS

October 19, 2021

### ITEM

SD-7: Environmental Stewardship Monitoring Report

### PURPOSE

To ensure full Board review, discussion and acceptance of SD-7: Environmental Stewardship Monitoring Report.

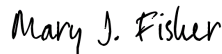
### FACTS

- a. The first set of Board policies was approved by the Board on July 16, 2015. A second set of Board policies was approved by the Board on October 15, 2015.
- b. Each policy was evaluated and assigned to the appropriate Board Committee for oversight of the monitoring process.
- c. The System Management and Nuclear Oversight Committee is responsible for evaluating Board Policy SD-7: Environmental Stewardship.
- d. The System Management and Nuclear Oversight Committee has reviewed the SD-7: Environmental Stewardship Monitoring Report as outlined on Exhibit A, and is recommending that OPPD be found to be sufficiently in compliance with the policy as stated.


### ACTION

The System Management and Nuclear Oversight Committee recommends Board approval of the 2021 SD-7: Environmental Stewardship Monitoring Report.

#### RECOMMENDED:

DocuSigned by:  
  
 C185DBBB12A4BA...  
 Mary J. Fisher  
 Vice President – Energy Production and Nuclear Decommissioning

#### APPROVED FOR BOARD CONSIDERATION:

DocuSigned by:  
  
 AC389FDCE66247E...  
 L. Javier Fernandez  
 President and Chief Executive Officer

Attachments: Exhibit A – Monitoring Report Resolution

# Monitoring Report SD-7 Environmental Stewardship

OPPD Board of Directors – All Committees Meeting  
October 19, 2021

Mary Fisher, Vice President – Energy Production & Nuclear Decommissioning

# SD-7: Where We've Been

## Resolution 6082, October 15, 2015

First issuance as part of Board Policies

## Resolution 6289, November 15, 2018

Major revisions:

- Long term goal: 20% reduction in carbon intensity from 2010 through 2030.
- Strive towards long-term goal of 50% of retail energy sales supplied from renewable energy sources.

## Resolution 6347, November 14, 2019

Major revisions. Revised to form and language of current SD7. Replaced goals of 6289 with net-zero carbon goal.

## Resolution 6434, May 20, 2021

Formally recognizes the scientific consensus that climate change is occurring and that greenhouse gas emissions, including carbon dioxide, from human activity contribute to climate change impacts.

The image shows a stack of documents related to the Omaha Public Power District Board Policy SD-7: Environmental Stewardship. The top document is the current policy, and the bottom document is a proposed revision. The proposed revision includes a table with the following information:

OMAHA PUBLIC POWER DISTRICT Board Policy		Category:	Strategic Direction
Policy No. and Name: SD-7: Environmental Stewardship		Monitoring Method:	System Management and Nuclear Oversight Committee Board Report
Date of Approval: October 15, 2015 November 15, 2018 November 14, 2019 (TBD)		Frequency:	Annually
		Resolution No.:	6082 6289 6347 64xx

Managing its interactions with the environment is essential to OPPD's ability to serve customers, create value for stakeholders, and contribute to the well-being of the communities it serves and its employees. The OPPD Board of Directors recognizes the scientific consensus that climate change is occurring and that greenhouse gas emissions, including carbon dioxide, from human activity contribute to climate change impacts.

Therefore, OPPD shall:

- Operate in an environmentally responsible manner and strive for the continuous improvement of its environmental performance.
- Conduct all of its operations (including operations such as building services and transportation) in a manner that strives for the goal of net zero carbon production by 2050.
- Conduct its business in a manner that meets all environmental regulatory standards, and go beyond compliance where practical.
- Be transparent by measuring and reporting its environmental performance on OPPD's website.
- Engage customers and stakeholders to promote energy conservation and efficiency and minimize environmental impact.
- Advocate and educate local, state and federal governments to protect and advance OPPD's environmental interest.

# SD-7: Environmental Stewardship

Managing interactions with the environment is essential to OPPD's ability to serve customers, create value for stakeholders, and contribute to the well-being of the communities it serves and its employees.

The OPPD Board of Directors recognizes the scientific consensus that climate change is occurring and that greenhouse gas emissions, including carbon dioxide, from human activity contribute to climate change impacts.



*Williams/Fisher*

## **RESOLUTION NO. 6434**

**WHEREAS**, the Board of Directors of Omaha Public Power District establishes policies through strategic directives to Management; and

**WHEREAS**, Strategic Directive 7: Environmental Stewardship (SD-7) has been adopted by the Board of Directors and revised most recently on November 14, 2019, pursuant to Resolution No. 6347; and

**WHEREAS**, consistent with the District's mission to provide affordable, reliable and environmentally sensitive energy services to its customer-owners, the Board of Directors recognizes the scientific consensus that climate change is occurring due to greenhouse gas emissions, including carbon dioxide, from human activity which affect the environment and our customer-owners; and

**WHEREAS**, work is underway at the District that will help address the effects of climate change, including large-scale renewable energy projects, the District's decarbonization strategic initiative, and emissions reductions across the District's generation fleet; and

**WHEREAS**, the Systems Management and Nuclear Oversight Committee of the Board of Directors recommends revision of SD-7 in the form attached hereto as Exhibit A.

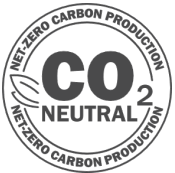
**NOW, THEREFORE, BE IT RESOLVED** by the Board of Directors of the Omaha Public Power District that OPPD Strategic Directive 7: Environmental Stewardship is hereby approved, as amended, in the form attached hereto as Exhibit A.

# SD-7: Environmental Stewardship

Therefore, OPPD shall:



Operate in an environmentally responsible manner and strive for continuous improvement of its environmental performance.



Conduct all operations in a manner that strives for the goal of net zero carbon production by 2050.



Conduct its business in a manner that meets all environmental regulatory standards and go beyond compliance where practical.

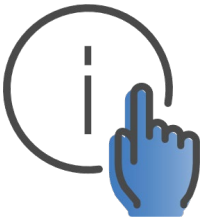
# SD-7: Environmental Stewardship



Be transparent by measuring and reporting environmental performance on OPPD's website.



Engage customers and stakeholders to promote energy conservation and efficiency and minimize environmental impact.



Advocate and educate local, state, and federal governments to protect and promote OPPD's environmental impact.



# Environmental Responsibility & Performance

Operate in an environmentally responsible manner and strive for continuous improvement of its environmental performance.

# OPPD's Vehicle Fleet

- Passenger car fleet is now 100% hybrid or fully electrified
  - 38 hybrid cars
  - 6 all electric cars
  - 4 extended range plug-in hybrids
- 282+ total vehicles that are all electric, hybrid, or flex fuel (~45% of fleet)
- Equipment
  - 45 all electric forklifts, yard carts, and man-lifts
  - 6 plug-in hybrid bucket trucks



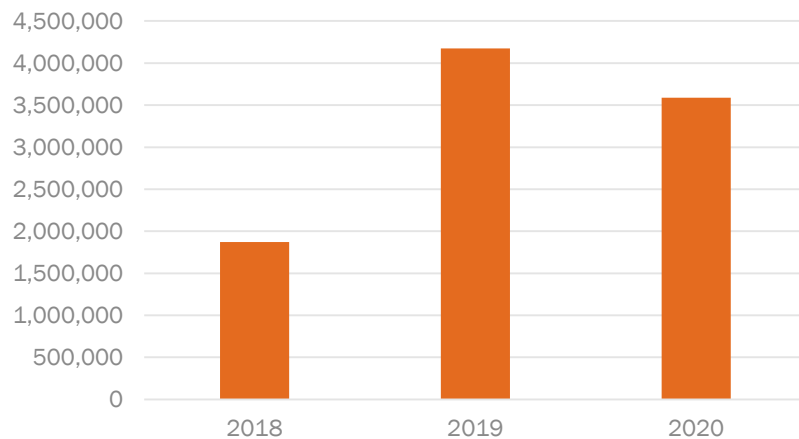


# 2020 Investment Recovery

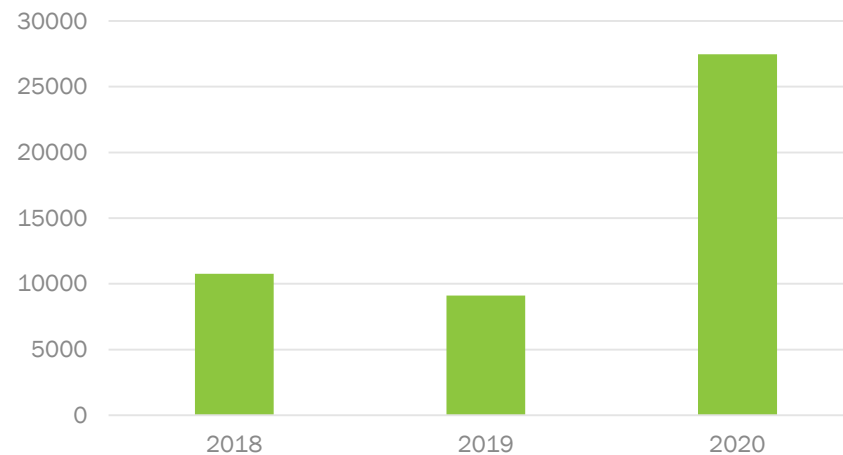
OPPD focuses on finding avenues for recycling:

- **Batteries** – 27,456 lbs.
- **Metal** – 3,587,134 lbs.
- **Oil** – 32,676 gallons
- **Utility Poles** – 800 poles  
(additional utility pole repurposing vendor - 2021)
- **Recycling materials** returned over \$2M back to OPPD.
- ~86% of **fly ash** recycled from NOS and 26% from NCS.
- New **oil recycler**

Pounds of Metal



Pounds of Batteries



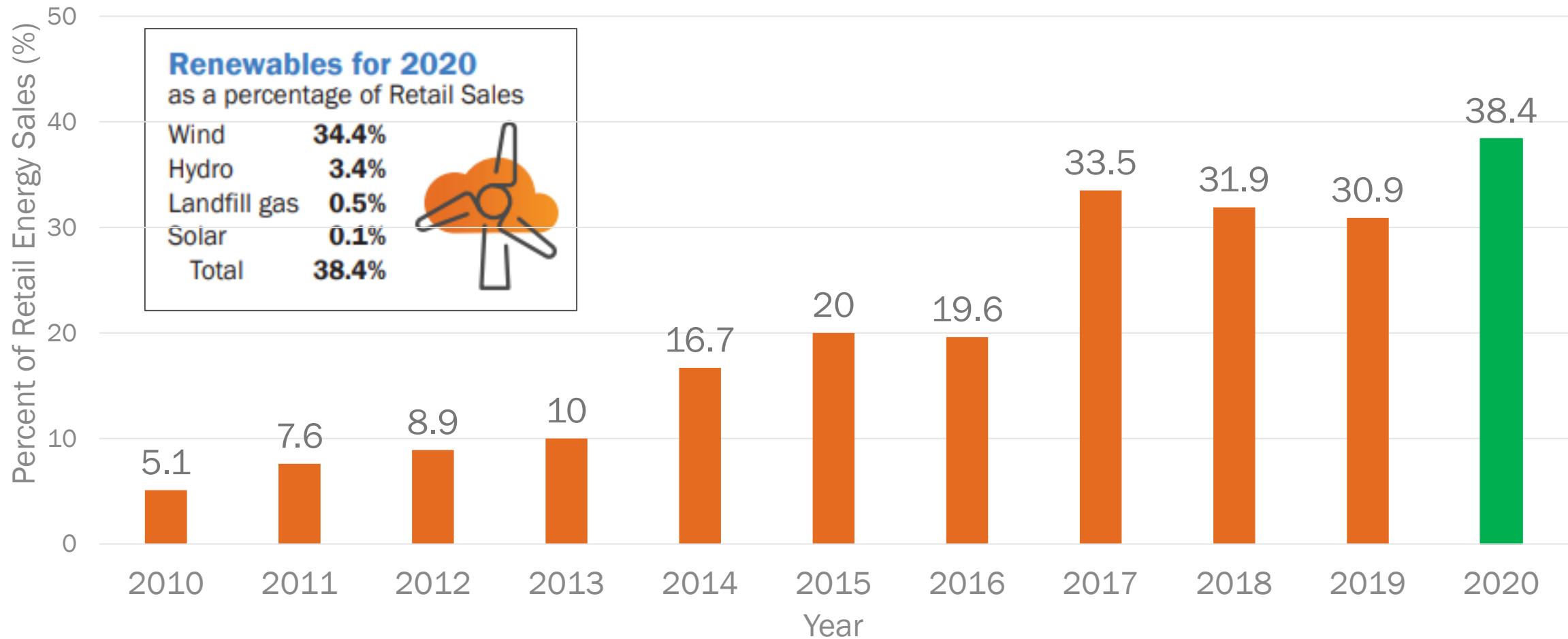
# FCS Focused Efforts

- Pre-demolition sales of over 150,000 lbs. of material: diesel generators, breakers, boiler, etc.
- Over 4,000 gallons of paint, oil and grease sold for reuse avoiding hazmat disposal costs
- Large portion of battery recycling was from the Fort Calhoun battery rooms





# OPPD Renewable Generation Over Time





# OPPD's Renewable Portfolio

 **HYDRO** - 81.3MW

 **WIND FARMS** - 972MW

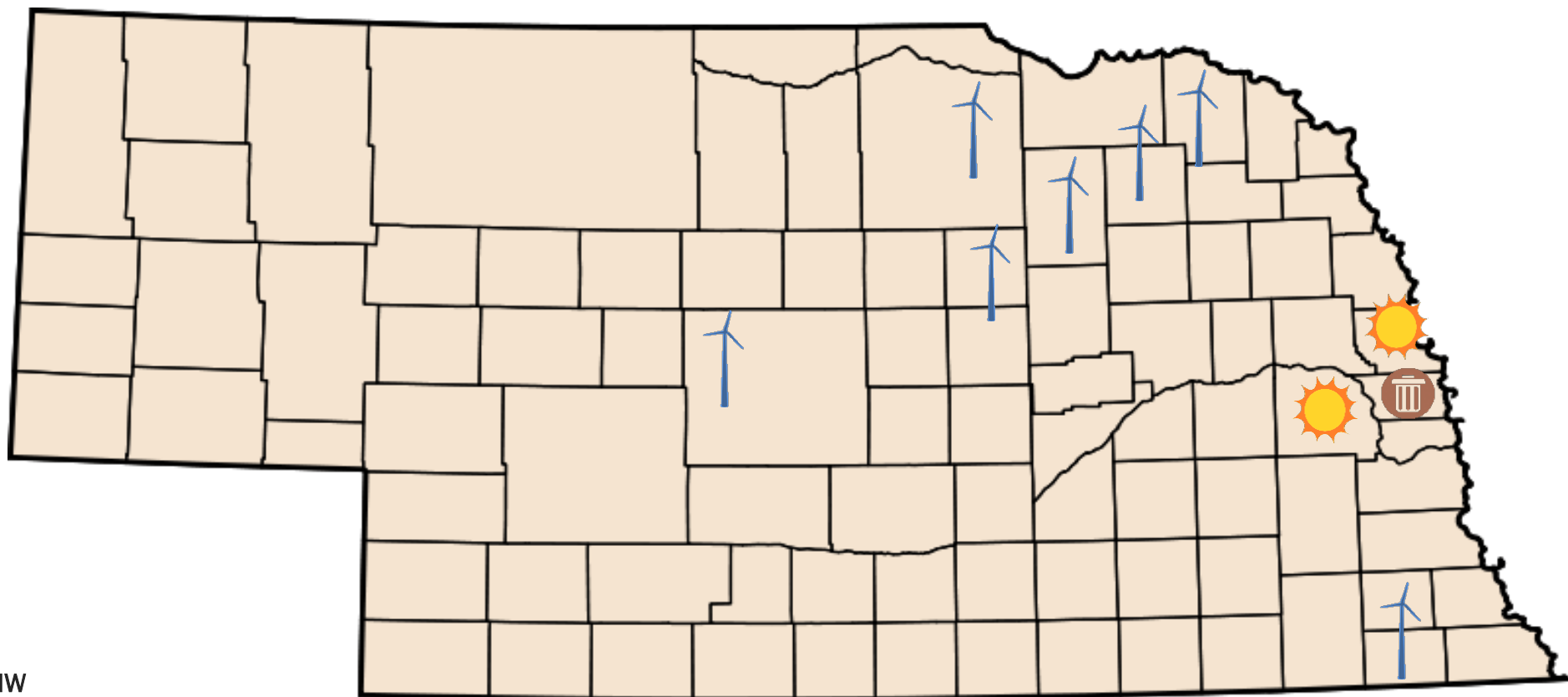
- Ainsworth (10MW)
- Broken Bow I (18MW)
- Broken Bow II (43.9MW)
- Petersburg (40.5MW)
- Elkhorn Ridge (25MW)
- Crofton Bluffs (13.6MW)
- Prairie Breeze (200.6MW)
- Flat Water (60MW)
- Grand Prairie (400MW)
- Sholes (160MW)

 **UTILITY-SCALE SOLAR\*** - 5MW

- Fort Calhoun Solar (5MW)

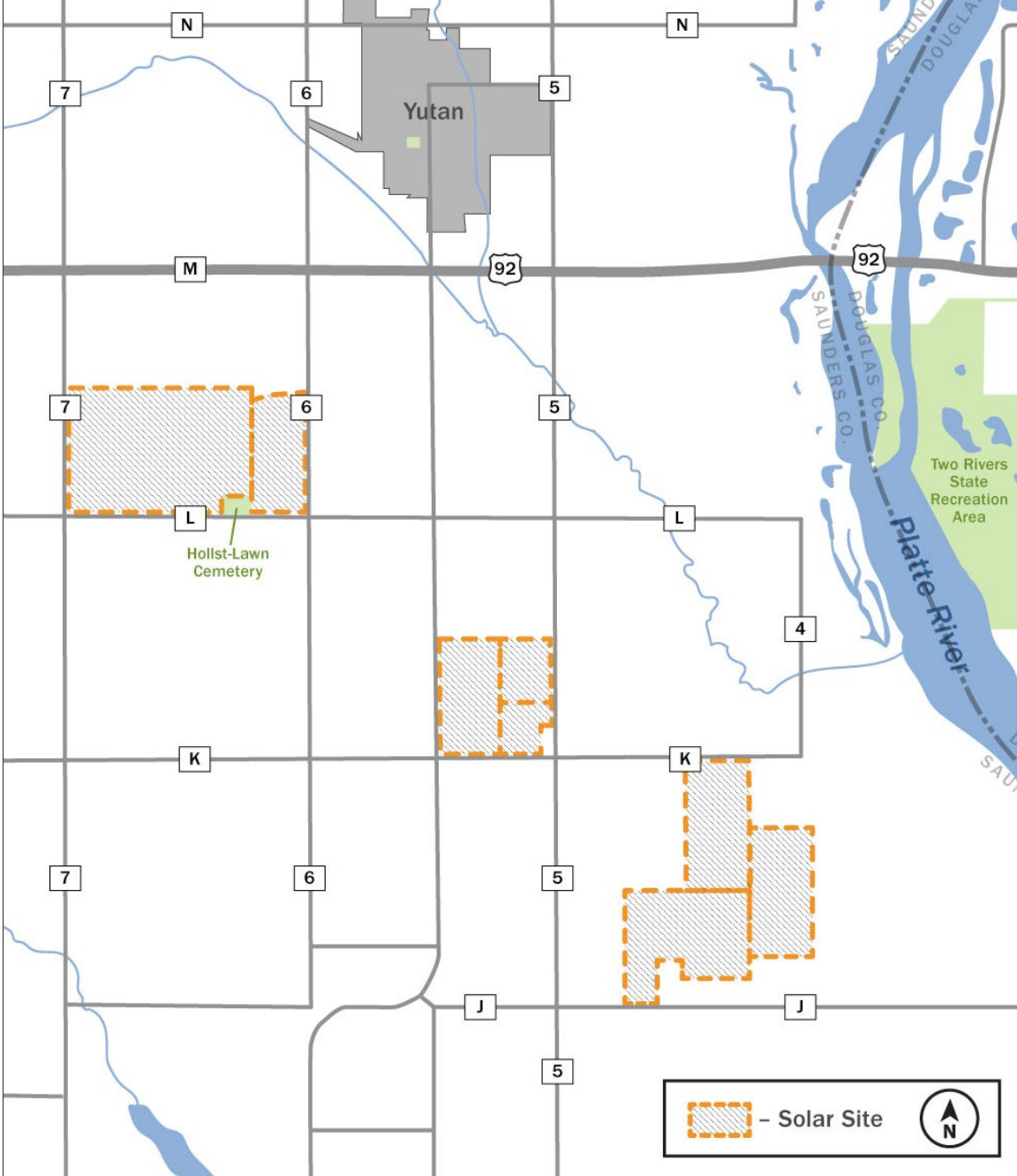
 **LANDFILL GAS** - 6.3MW

- Elk City Station (6.3MW)



**Installed Capacity: 1064.2 MW nameplate**

\*Planned Addition for 2023: Platteview Solar (81MW)



# Power with Purpose Solar Announcement: Platteview Solar



- Size: 81 MWAC
- Location: South of Yutan in Saunders County, NE
- Planned operation date: Spring 2023
- Contract term: 20 years





# BRIGHT Grant & Project Scoping

(Battery Research Innovation Guided by High Potential Technologies)

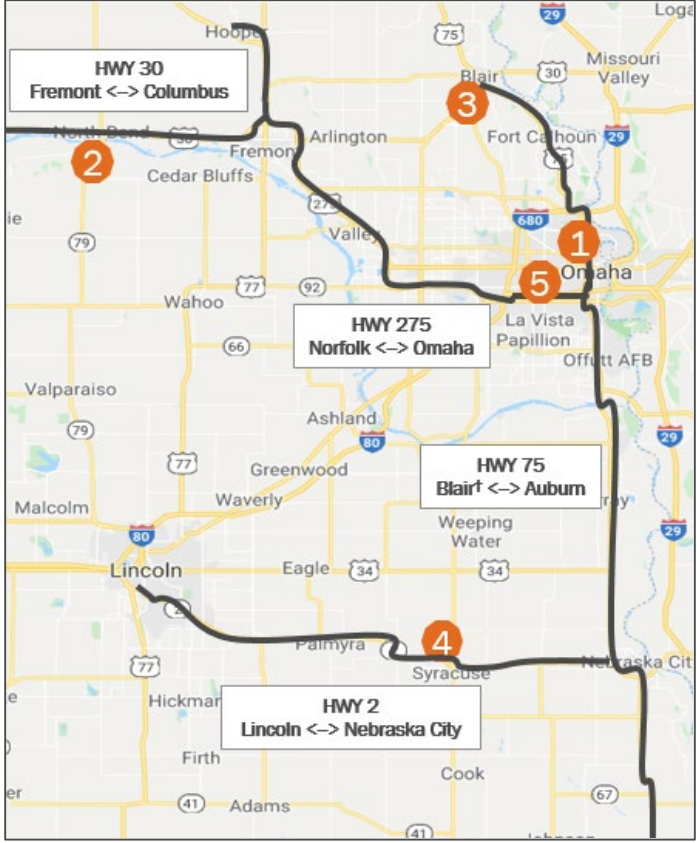
- Nebraska Environmental Trust (NET) Air Quality Category
  - OPPD application submitted September 2019
  - NET funds approved June 2020
  - Grant project funding: \$600,000
- Project to facilitate OPPD technology and operational learning
  - Allows OPPD to learn about interconnection, permitting, engineering, construction, operations, and safety requirements
- Project specifics based on grant application
  - Size: ~1MW
  - Location: OPPD substation in Cass County
  - Technology: not specified



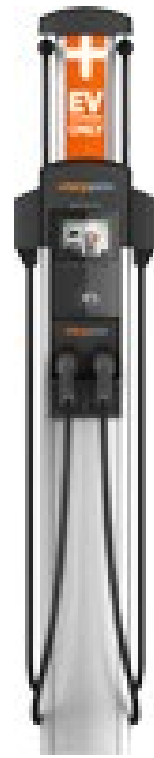


# Electrical Vehicle Programs: NDEE Grant

- This Program was made possible by a grant from the Nebraska Department of the Environment and Energy (NDEE)
- Applied to NDEE for multiple sites
- Each site will receive a Level 2 and DC Fast Charger (DCFC)
- DCFC's require dedicated electric service
- Five sites awarded – all are located on major highway crossings
  1. City of Omaha – 17<sup>th</sup> & Chicago
  2. Casey's – North Bend
  3. Casey's – Blair
  4. Casey's – Syracuse
  5. Cabela's - LaVista



**NEBRASKA**  
 Good Life. Great Resources.  
 DEPT. OF ENVIRONMENT AND ENERGY



Level 2 Charger  
~4-6 hours

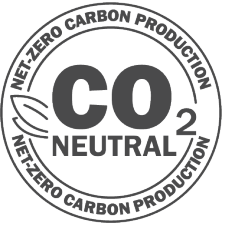


DC Fast Charger  
~1 hour

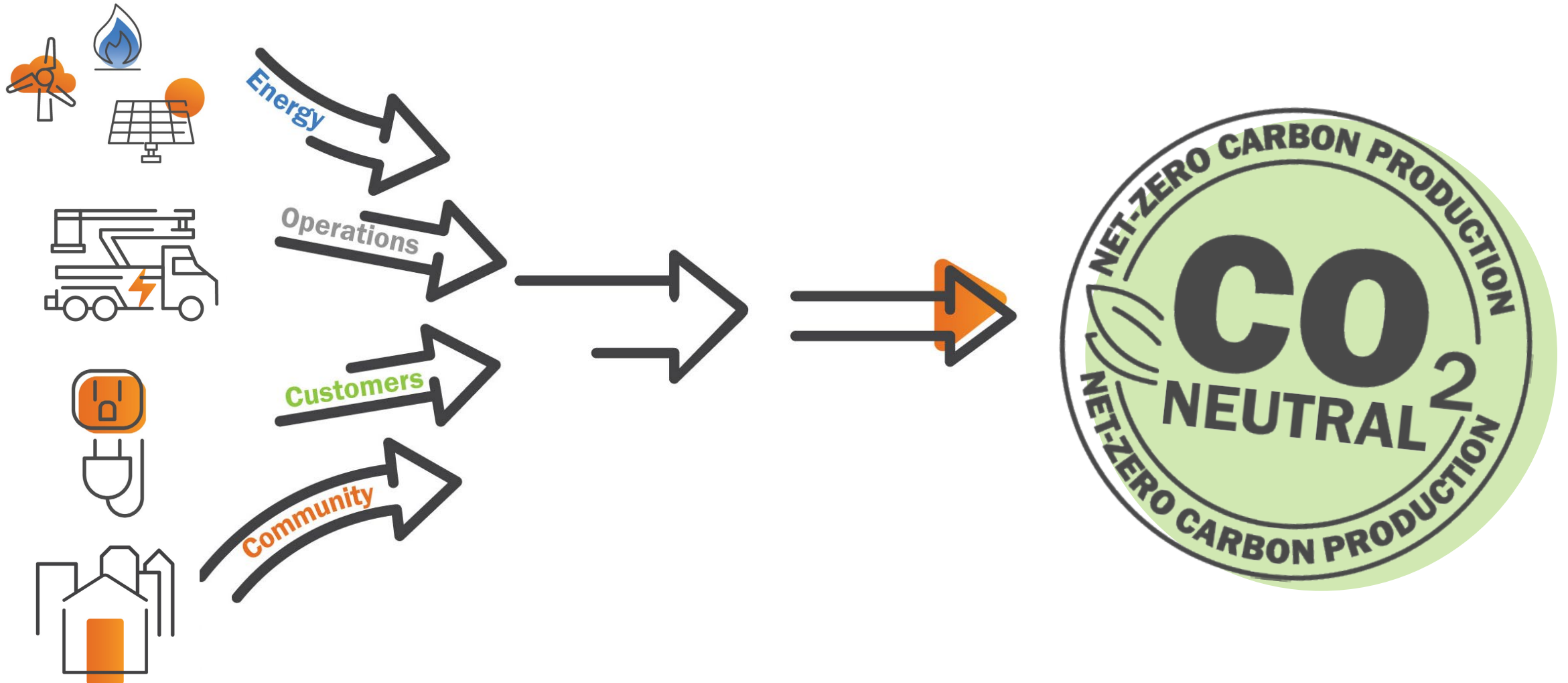
# Net Zero Carbon Production Goal by 2050

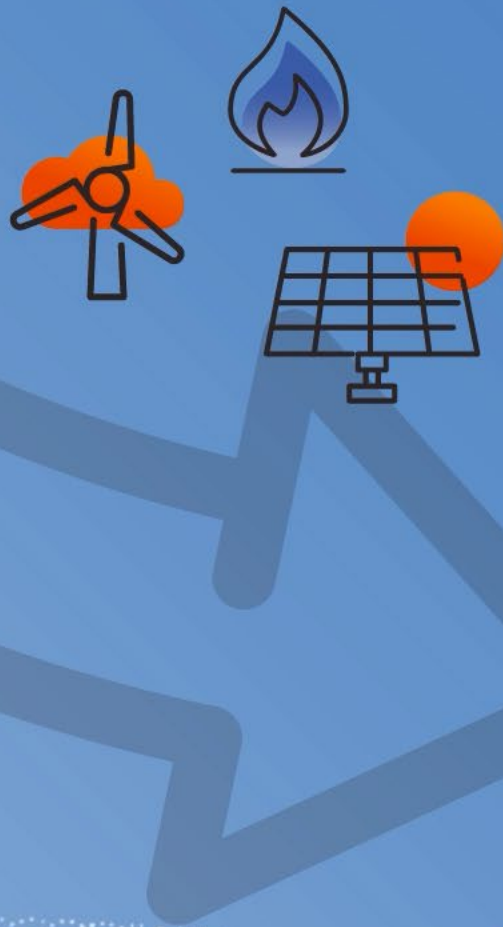
Conduct all operations in a manner that strives for the goal of net zero carbon production by 2050.





# Pathways to Decarbonization





# PATHWAY: ENERGY PORTFOLIO

## Completed Objectives

- Completed multi-sector modeling to establish plausible economy-wide pathways to decarbonization and determine OPPD's potential future electric demand forecast
- Developed a reliability and resiliency analysis framework for utilization in Portfolio Optimization
- Analyzed a universe of potential technologies to support decarbonization. Technologies were then aggregated and screened into a list of 18 candidate technologies to be modeled.



# PATHWAY: **INTERNAL OPERATIONS**

## Completed Objectives

- Developed a standardized carbon accounting framework
- Base year 2018 and 2019 GHG inventories

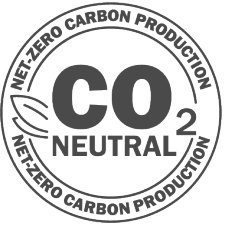


# PATHWAY: **CUSTOMERS**

---

## Completed Objectives

- Developed and piloted repeatable product evaluation framework
- Completed Phase 1 Analysis of 228 concepts covering all aspects of decarbonization
- Completed detailed research and analysis on the 26 top scoring concepts from Phase 1



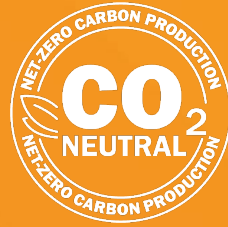


# PATHWAY: **COMMUNITY**

---

## Completed Objectives – Study focused on:

- Understanding community decarbonization
- Identifying and cataloging community-scale decarbonization strategies (CAP catalog)
- Developing an evaluation framework based on GHG reduction potential, OPPD's degree of influence, and co-benefits
- Prioritizing potential decarbonization strategies where OPPD is well positioned to lead change



# PATHWAY: **COMMUNITY**

---

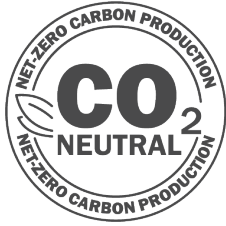
## Completed Objectives

- Identified four areas of opportunity where OPPD is well positioned to lead change:
  1. Advocate for advanced energy codes and green building standards
  2. Accelerate transition to electric vehicles
  3. Support distributed generation
  4. Address the water-energy nexus

# Demand Side Management Portfolio Status

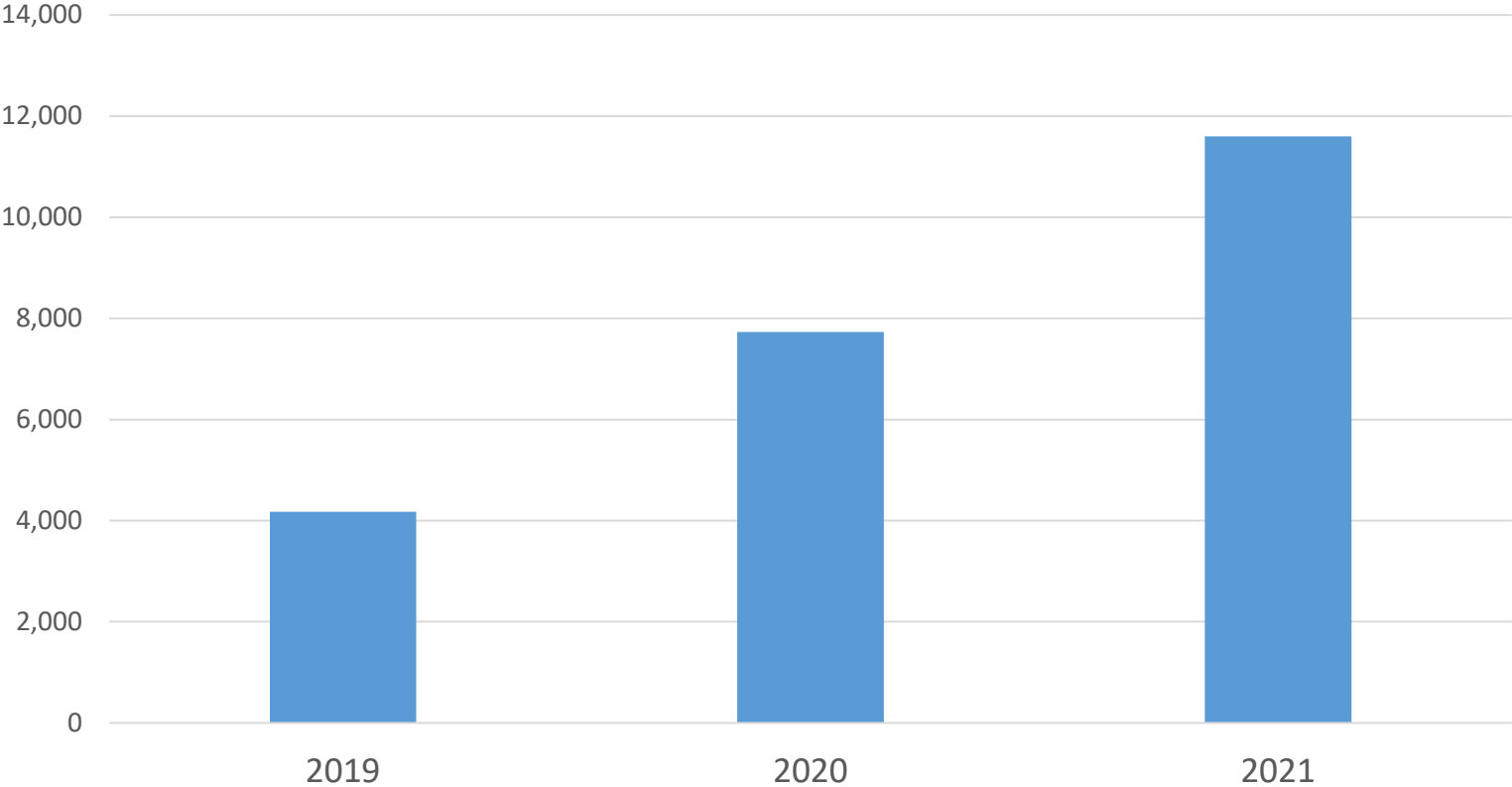


	2019 Actuals	2020 Actuals		2021 Goal	
	MW	MW	MWH	MW	MWH
<b><i>Demand Response</i></b>					
Smart Thermostat Program	6.560	5.244		6.089	
Cool Smart	63.330	64.415		64.650	
Business Interruptible	50.970	50.970		50.910	
<b>Total Demand Response</b>	<b>120.860</b>	<b>120.629</b>		<b>121.649</b>	
<b><i>Energy Efficiency</i></b>					
Smart Thermostat Program					386.17
HVAC Smart	1.415	1.756	1,610.39	1.5	925.50
Certified High-Performance Homes	0.145	0.121	30.49	0.125	348.50
Energy Efficiency Assistance Program (EEAP)	0.002	0.012	104.31	0.01	31.73
Business Prescriptive Rebates	3.679	2.629	8,836.28	4	15,332.00
Business Custom Rebates	0.653	0.241	2,224.36	0.4	2,203.20
Other Programs				0.41	852.59
<b>Total Annual Energy Efficiency</b>	<b>5.894</b>	<b>4.759</b>	<b>12,805.83</b>	<b>6.445</b>	<b>20,079.69</b>
<b>Total Cumulative Energy Efficiency</b>	<b>36.282</b>	<b>41.041</b>		<b>48.226</b>	
<b>Total Annual Cumulative Demand Side Management</b>	<b>157.142</b>	<b>161.67</b>		<b>169.875</b>	



# LED Street Lighting

Annual CO<sub>2</sub> reduction in Tons

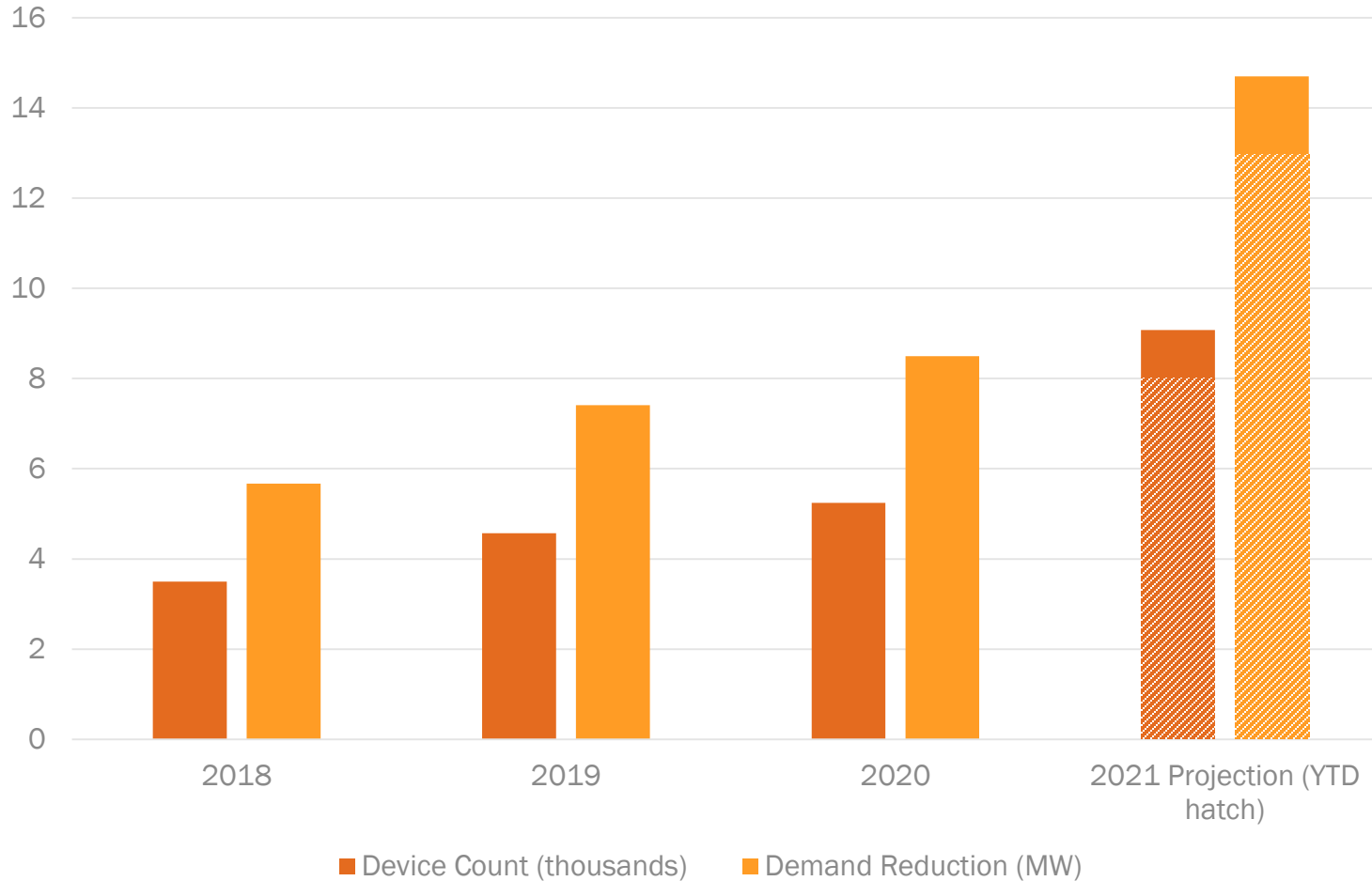
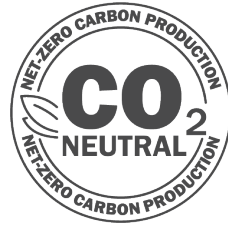


- LED street lighting replacements have created a projected annual energy savings of 23,000 MWH.
- LED street lighting has resulted in a 27.6% reduction in street light maintenance calls reducing the total truck rolls.





# Smart Thermostat Program

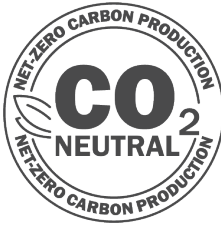


- May 2021 Added additional manufactured devices (Ecobee, Emerson, Honeywell)
- 46% increase in participation since expansion. 2021 YTD = 7,959 devices.
- 4.2MW demand response growth with expansion
- 12.9MW total demand reduction YTD.
- 3566MWh total annual energy efficiency\*
- 2623 tons total CO2 reduction annually\*\*

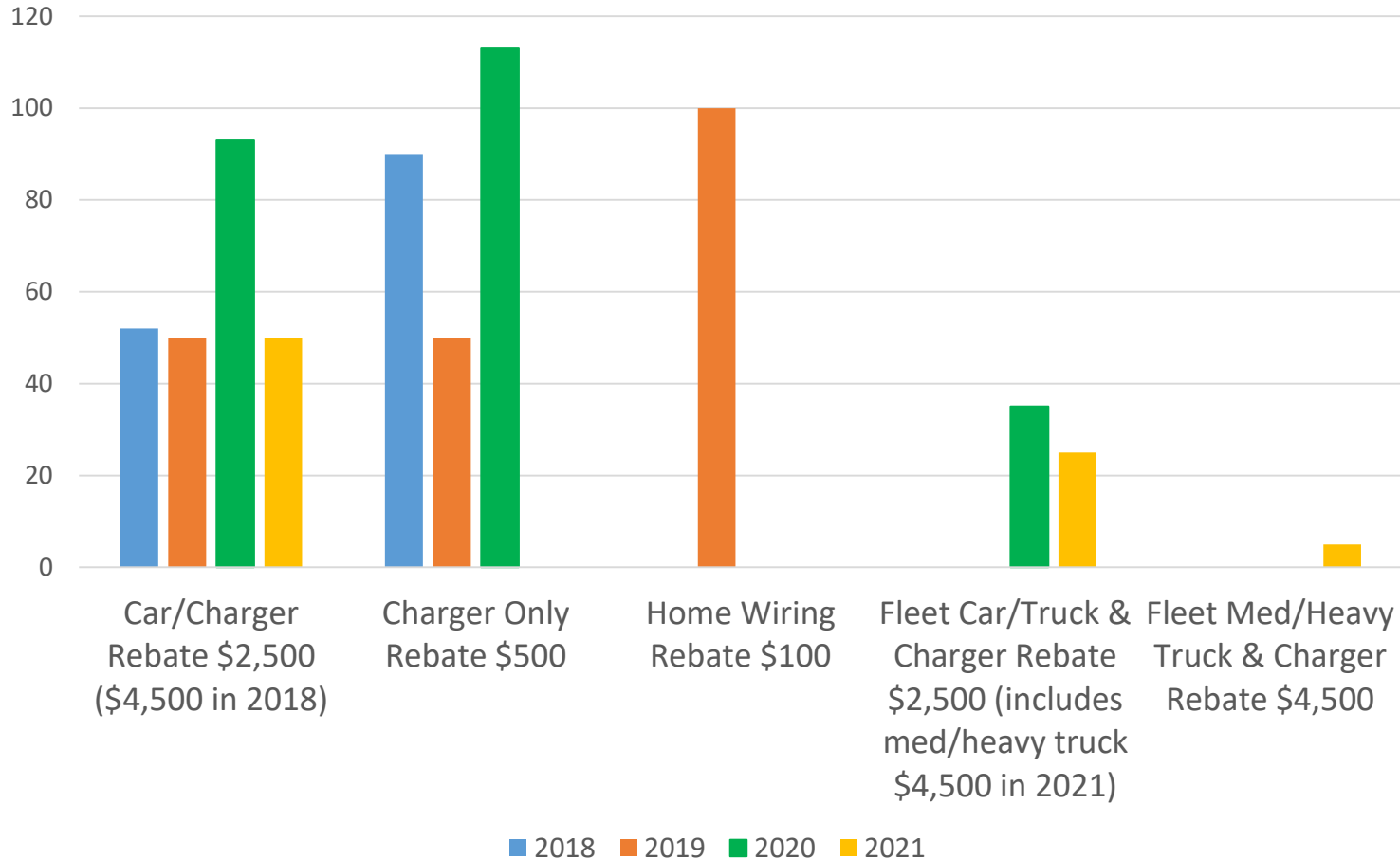
\*Per 2019 DSM Potential Study  
 \*\*Per 2020 Fleet Carbon Intensity Factor



# Electric Vehicle Rebate Program



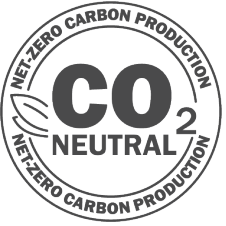
OPPD EV Rebates Available by Year



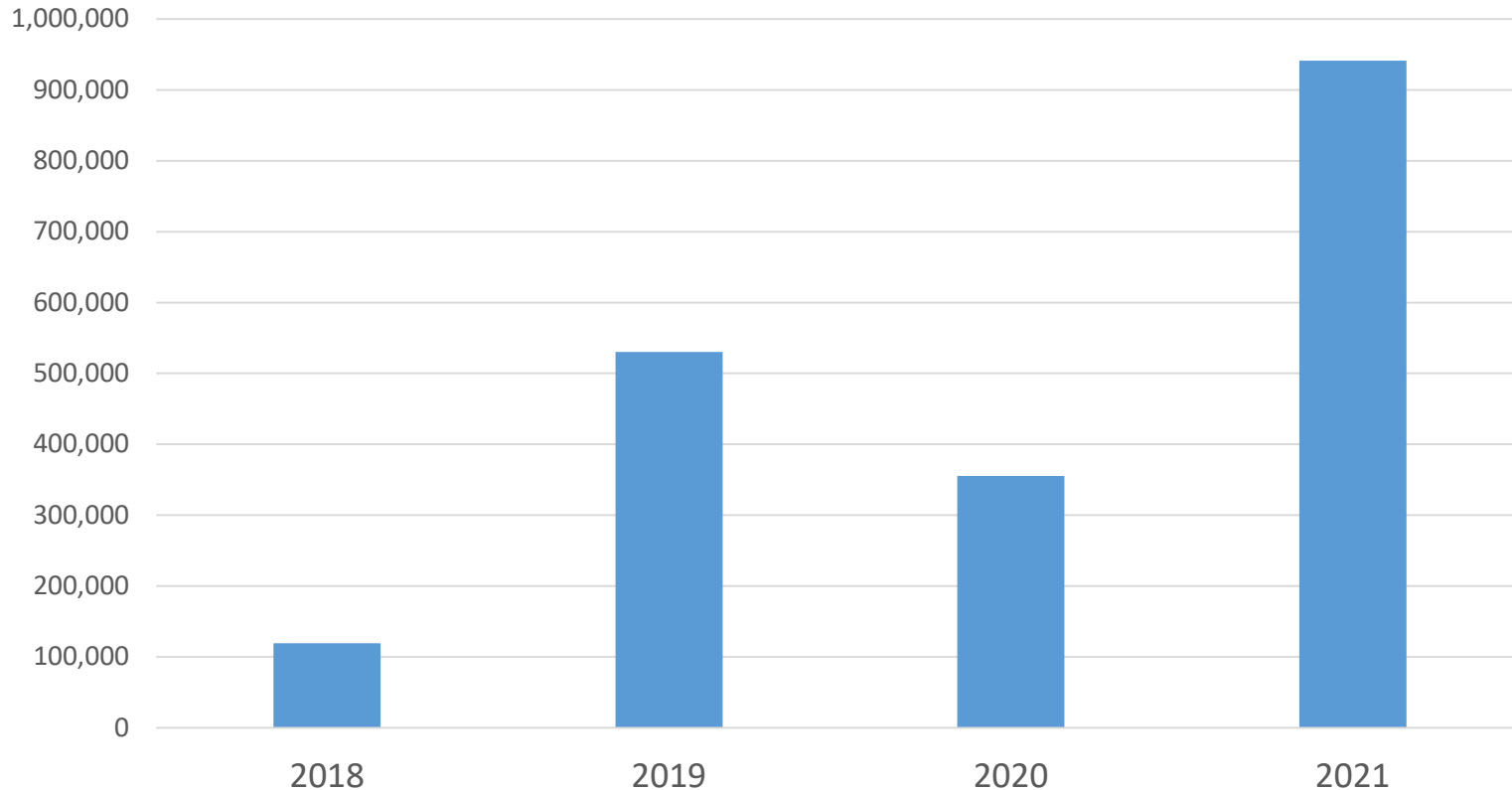
- All available rebates in 2018 and 2019 and 2020 were claimed
- 2021 residential rebate promotions began in August with 50 rebates available–11 rebates in approval process
- New in 2021 different Fleet rebate options including car/light truck and medium/heavy truck rebates with promotion beginning in September



# Electric Vehicles Making an Impact



Green House Gas (GHG) Emissions Saved in lbs\*



\*Emissions estimates supplied by ChargePoint

- Since the rebate program began in 2019, OPPD has helped customers save over 1.8M lb. of GHG emissions.
- That's the equivalent of planting 13,636 trees and letting them grow for 10 years!



# Meet & Exceed Environmental Regulatory Standards

Conduct business in a manner that meets all environmental regulatory standards and go beyond compliance where practical.

# No Violations of Environmental Permits Resulting in Fines or Enforcement Actions



## Standard Compliance

30+ environmental regulated permits held

- Consists of Air, Water, Waste, Natural Resources
- Conducted monthly, quarterly, semi-annual and annual internal inspections.
- Facilitated three virtual NPDES inspections by the NDEE (FCS, NCS, NOS).
- Facilitated multiple City of Omaha and NDEE air inspections (NOS, NCS, CCS, JSS, SCS).

## Beyond Compliance

- Plant wide Applicability Limit (PAL) Permit
- Low Emitter Status
- Near zero opacity excursions
- Complying with stormwater requirements at SCS, CCS, JSS though not required.
- Prairie in Progress
- Avian Protection, working with NGPC to conduct bird surveys



# Low Emitter Status

## Low Emitter Status

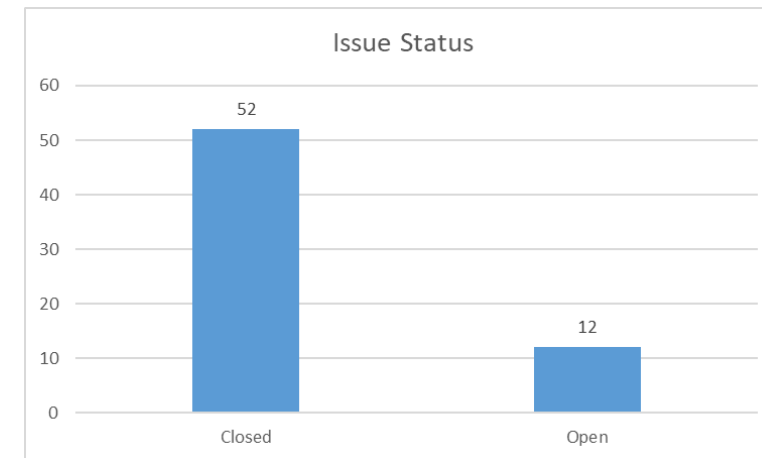
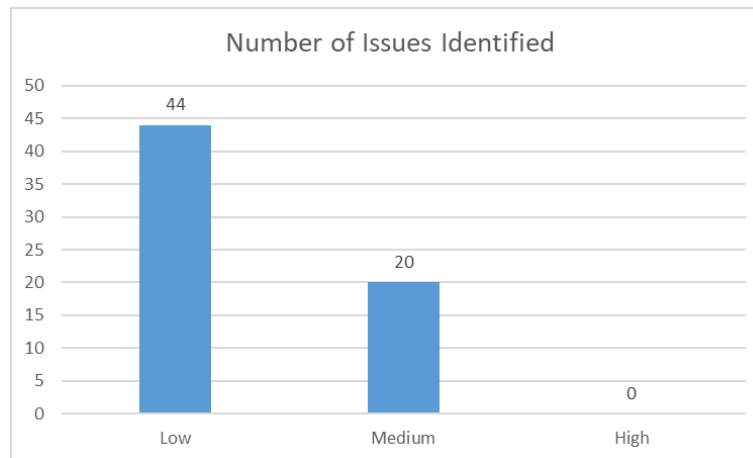
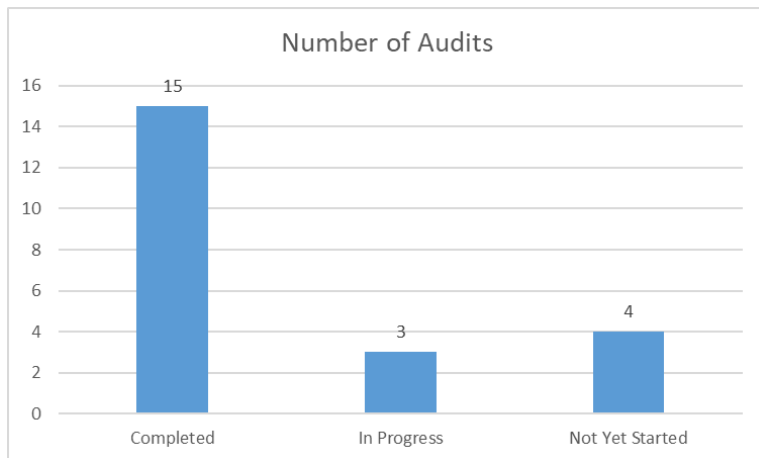
UNIT	PM	HCI	Hg
Nebraska City Unit 1	Obtained 1Q2019 Next Test: 1Q2022	1 of 12 Quarterly tests complete	Not Applicable*
Nebraska City Unit 2	Obtained 1Q2018 Next Test: 1Q2024	SO2 as surrogate	Not Applicable*
North Omaha Unit 4	Obtained 1Q2019 Next Test: 1Q2022	Obtained 3Q 2020 Next Test: 3Q2023	Obtained June 2016 Next Test: June 2022
North Omaha Unit 5	Obtained 1Q2020 Next Test: 1Q2023	Obtained 1Q2019 Next Test: 1Q2022	Obtained June 2016 Next Test: June 2022

\* Continuous monitoring is used to demonstrate compliance

Low Emitter Status is achieved after 12 consecutive quarterly tests at 50% below the Mercury and Air Toxics Standard for that constituent, except for Hg, which requires annual testing.



# Environmental Audit



- Advantages and improvements of moving the environmental audit function to corporate auditing:
  - Helped align the audit function with International Standards for the Professional Practice of Internal Auditing (Standard 1100–*The internal audit activity must be independent, and internal auditors must be objective in performing their work*)
  - Took advantage of existing corporate audit issue tracking and reporting structure (increased transparency and accountability)
    - Monthly reminders sent to issue owners on any open issues
    - Quarterly updates/reports to Senior Management Team
    - Annual presentation/report to the Board of Directors
- OPPD facilities are doing well complying with environmental regulations (i.e., there have been no high-risk issues identified to-date)
- Over 80% of identified issues have been corrected to-date



# Transformer Oil PCB Sampling



- A database of transformer PCB levels is being developed to assist in prioritization of replacement planning efforts.
- Total number of transformers in service territory: 90,770
- Transformers with unknown PCB levels: 21,000
- Work began in early 2020. Inspection 48% complete as of July 29, 2021
- Transformers Inspected: 10,123
- Transformers found 50-499 ppm = 1,217 (12%)
- Transformers found >500 ppm = 13 (0.13%)
- Additional benefits
  - Other maintenance items have been identified and fixed early.







# Osprey Tower Project



- New, 65-foot tower provides Osprey habitat.
- Provided as potential replacement for FCS Meteorological Tower, removed as part of decommissioning.
- FCS tower removed during migratory birds non-nesting season, OPPD provided new habitat by the end of March.
- Osprey returned shortly after nest construction in March.
- Partnering with Nebraska Game and Parks to provide camera and live video feed. Expect to be available by the end of the year.



# Peregrine Falcons at North Omaha



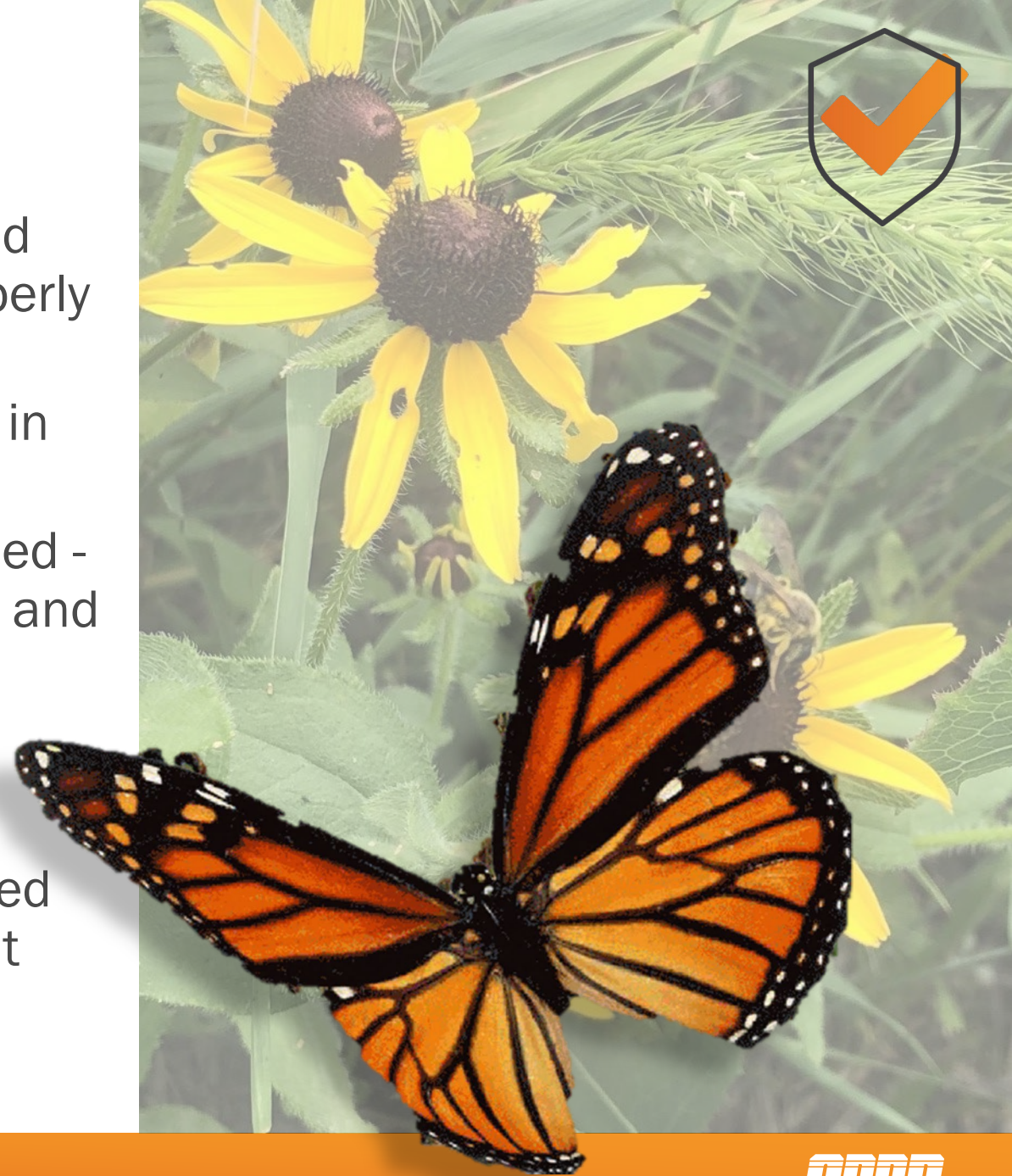
*Flash, Flicker,  
Storm (2020)*



*Volta, Watt, Ohm,  
Ampere (2021)*

# Prairie in Progress (PIP)

- After initial trial on 325 acres, OPPD recognized more intensive program was necessary to properly establish prairie
  - Three sites totaling 50 acres were targeted in 2020
  - New seed mix used, sites tilled and re-seeded - seed mix included 8 grass & sedge species and 38 forb/wildflower species
  - All sites being monitored in growing season for performance
- June Monitoring report from one of the improved sites - 12 species of insects observed, 27 plant species in bloom
- 2021 adding 6 acres on two new sites





# Active Transparency

Be transparent by measuring and reporting environmental performance on OPPD's website.



# OPPD's Environmental Programs & Reports

The screenshot shows the 'ENVIRONMENT' page on the OPPD website. The navigation bar includes links for RESIDENTIAL, BUSINESS, OUTAGES, ENVIRONMENT, NEWS & RESOURCES, ABOUT, and COMMUNITY. A sidebar on the left contains utility links: PAY MY BILL, REPORT AN OUTAGE, OUTAGE INFORMATION, START/STOP/MOVE, and MYACCOUNT. The main content area features a large 'ENVIRONMENT' header with a background image of a person on a construction site. Below this, there are several sections: 'LEADING THE WAY WE POWER THE FUTURE' with a recycling icon and text about OPPD's mission; 'Diverse Fuel Mix' with a list of fuel sources; 'Renewables' with a list of percentages for Wind, Hydro, Landfill Gas, and Solar; 'Electric Vehicles' with a car icon and text about EV integration; 'SOLAR POWER' with a solar panel icon and text about solar research; 'ENERGY EFFICIENCY' with a lightbulb icon and text about energy-saving products; and 'PEREGRINE FALCON LIVE CAM' with a video player and text about the live cam.

The screenshot shows the 'ENVIRONMENTAL PROGRAMS' page on the OPPD website. The navigation bar is the same as the previous page. The main content area features a large 'ENVIRONMENTAL PROGRAMS' header with a background image of a person on a construction site. Below this, there are several sections: 'NATURAL RESOURCE MANAGEMENT' with a 'PRAIRIE PROGRESS' image and text about stewardship; 'CORPORATE RESPONSIBILITY' with a 'PRAIRIE PROGRESS' image and text about government utilities; 'ENERGY EFFICIENCY' with a 'Be wise, weatherize' image and text about energy-efficient products; and 'WE HAVE THE PERFECT SITE FOR YOUR BUSINESS' with a 'LEARN MORE' button. A sidebar on the left contains utility links: PAY MY BILL, REPORT AN OUTAGE, OUTAGE INFORMATION, START/STOP/MOVE, and MYACCOUNT. The main content area also includes a 'Your energy partner' logo and a 'Home > Environment > Environmental Programs' breadcrumb.

The screenshot shows the 'ENVIRONMENTAL REPORTS' page on the OPPD website. The navigation bar is the same as the previous pages. The main content area features a large 'ENVIRONMENTAL REPORTS' header with a background image of a person on a construction site. Below this, there are several sections: 'AVIAN PROTECTION PLAN' with a photo of a person and text about protecting avian populations; 'FLEET EMISSIONS' with a photo of a truck and text about emissions reports; and 'CCR RULE COMPLIANCE DATA & INFORMATION' with a photo of a truck and text about EPA reports. A sidebar on the left contains utility links: PAY MY BILL, REPORT AN OUTAGE, OUTAGE INFORMATION, START/STOP/MOVE, and MYACCOUNT. The main content area also includes a 'Your energy partner' logo and a 'Home > Environment > Environmental Reports' breadcrumb.

# Environmental Input Collected through **OPPDCommunityConnect.Com**



## OPPD Board Feedback: SD-7

From time to time, OPPD's Board of Directors call on customers for feedback on specific topic. This feedback included: SD- 7

[Read more](#)



## OPPD BRIGHT Project

OPPD's first battery storage project and we are excited to share the details with you.

[Read more](#)



## Pathways to Decarbonization

By partnering with customers and communities, OPPD is striving for net-zero carbon production by 2050.

[Read more](#)



## ONLINE WORKSHOPS

## Decarbonization: Energy Portfolio Online Workshops

Recordings of all past workshops and updates are available to view. In addition, a summary video of past

[Read more](#)



## CCR Selection of Remedy for North Omaha Station

Register for the Public Meeting held Sept. 22. Public comment accepted Sept. 8 - Oct. 8.

[Read more](#)



## CCR Selection of Remedy for Nebraska City Station 2

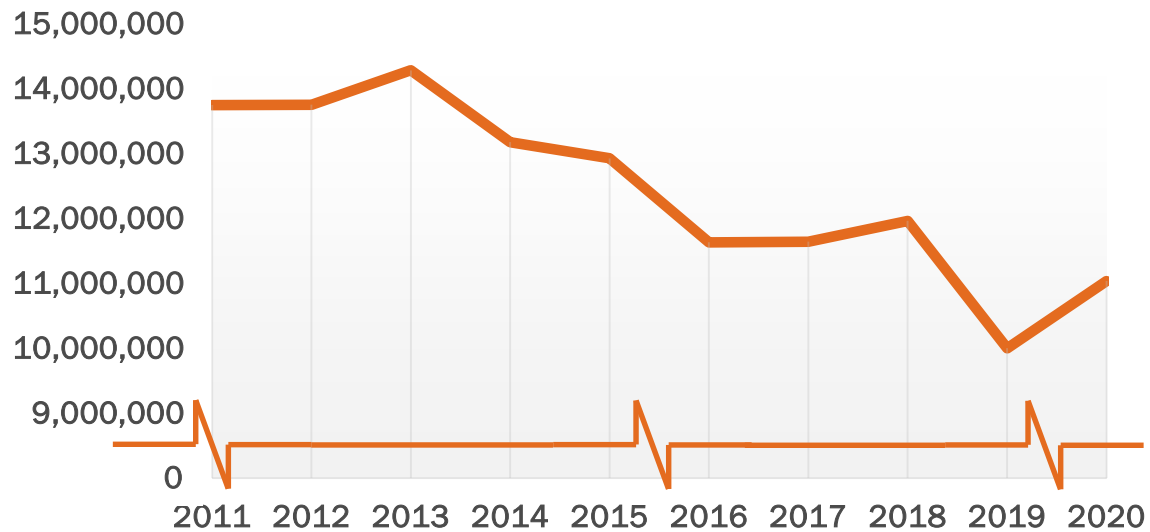
The public meeting was held August 25. You may watch the recording here.

[Read more](#)

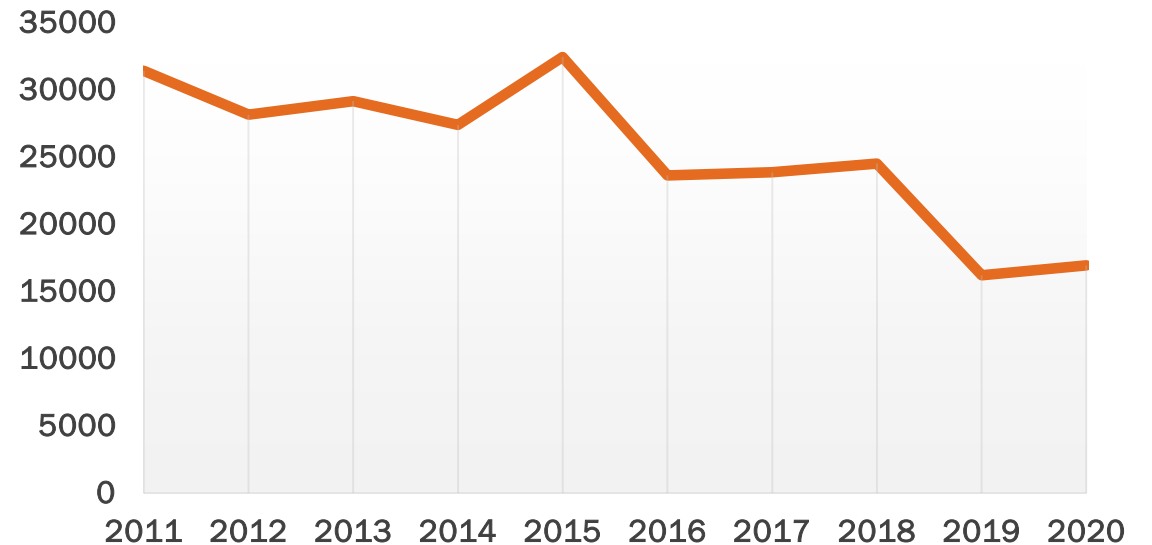
# Annual Emissions



## CO<sub>2</sub> (Tons)



## SO<sub>2</sub> (Tons)



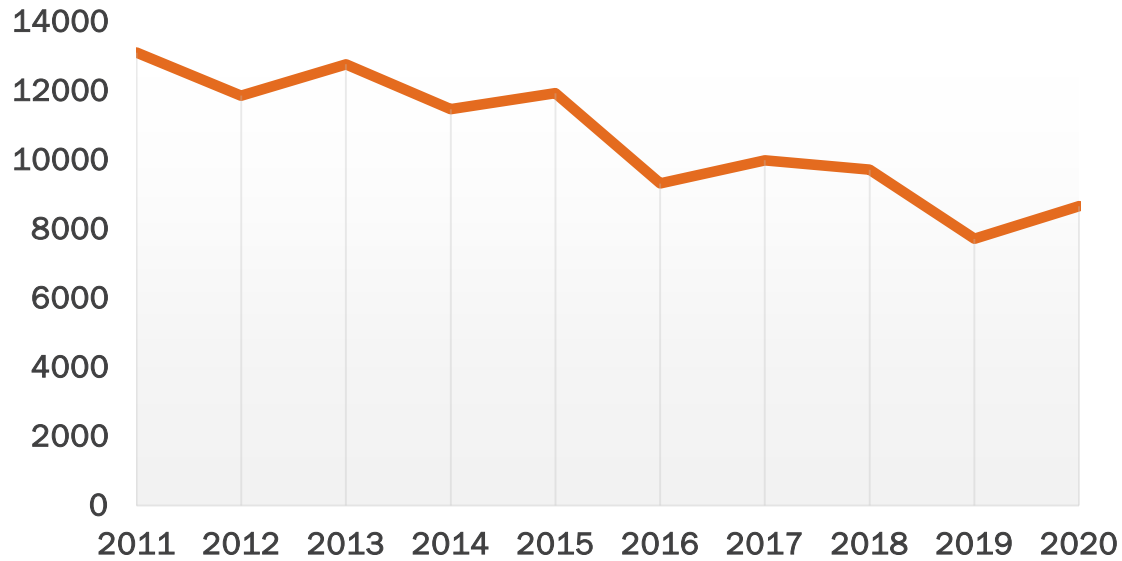
### Notes:

1. 2019 emissions drop due primarily to major unit outages at NCS units.
2. Emission data shown here through 2020. Emission data is updated annually and posted each spring (~February) at <https://www.oppd.com/environment/environmental-reports/fleet-emissions/>.

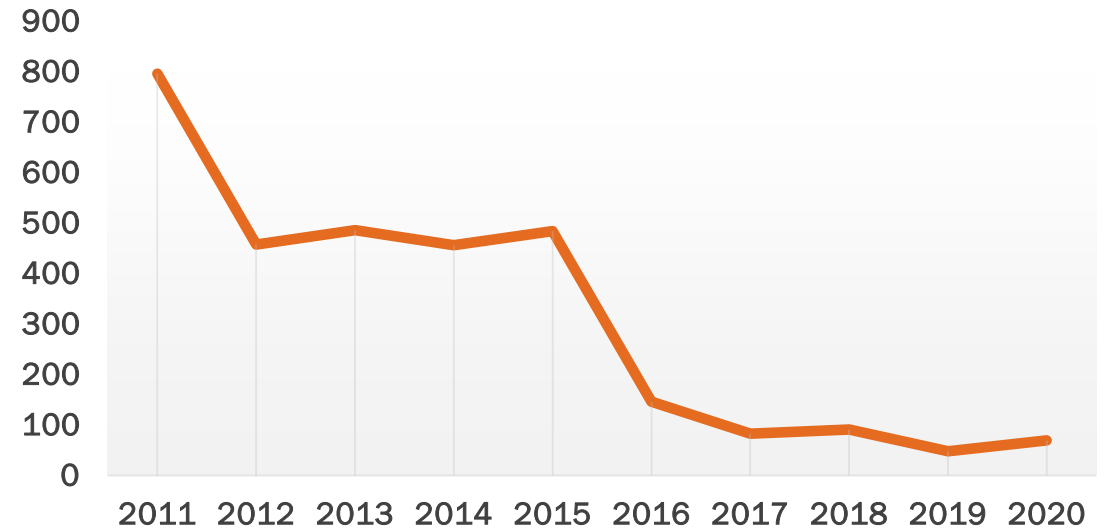
# Annual Emissions



## NOx (Tons)



## Hg (Pounds)



### Notes:

1. 2019 emissions drop due primarily to major unit outages at NCS units.
2. Emission data shown here through 2020. Emission data is updated annually and posted each spring (~February) at <https://www.oppd.com/environment/environmental-reports/fleet-emissions/>.



# Community Solar Dashboard



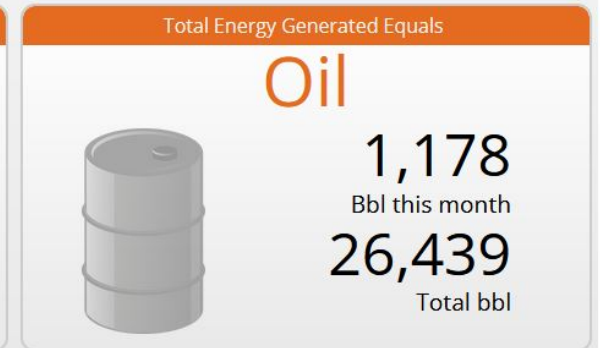
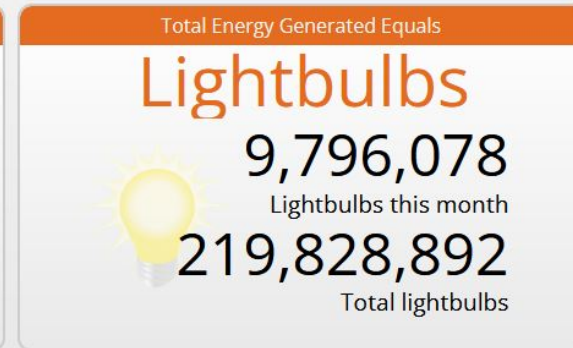
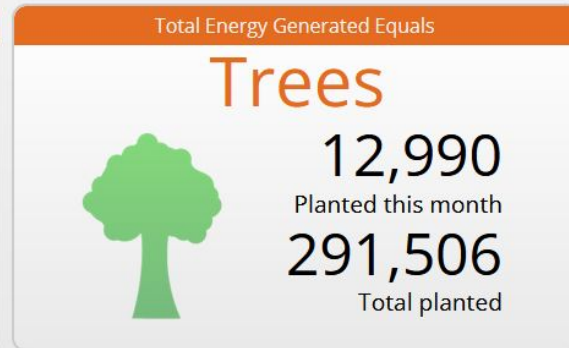
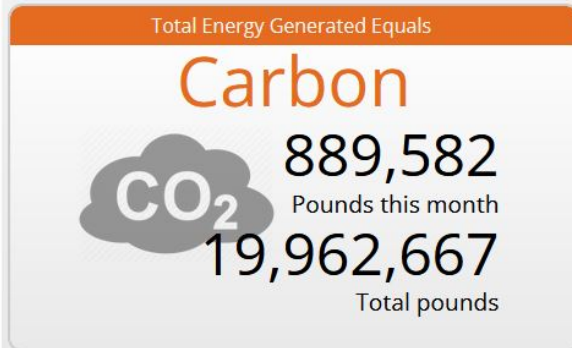
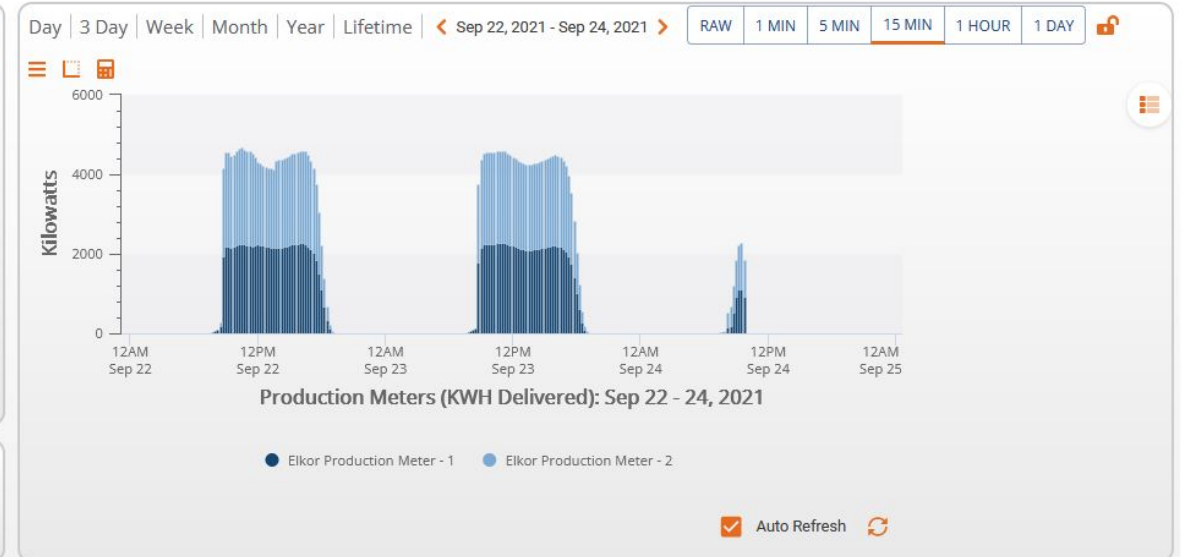
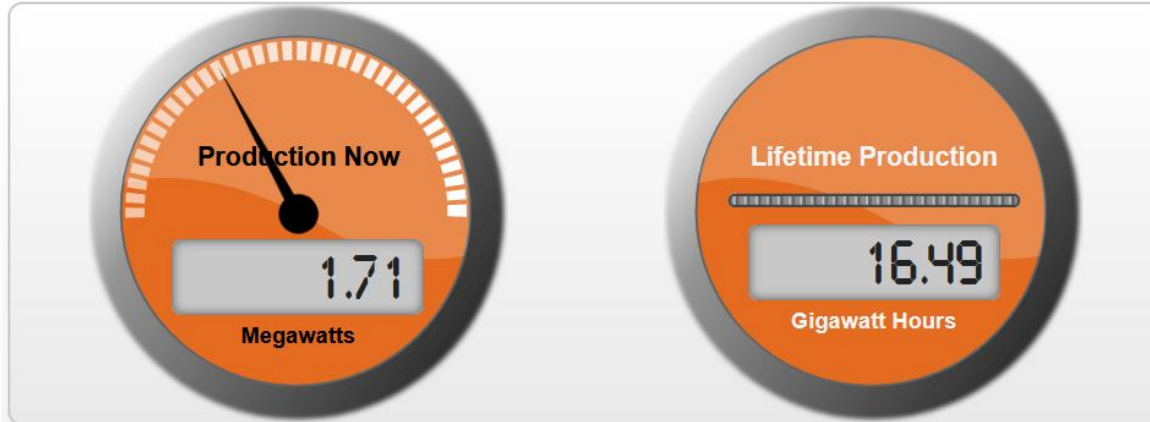
## Community Solar

System Size: 5 MW  
 Generating Since: Dec 16, 2019  
 Last Updated: 9:47AM Sep 24, 2021

Home

Graph

How Solar Works





# Customer & Stakeholder Engagement

Engage customers and stakeholders to promote energy conservation and efficiency and minimize environmental impact.

## ENERGY EFFICIENCY

- ENERGY-SAVINGS FLOOR PLAN
- ENERGY-EFFICIENCY TIPS
- VIDEO LIBRARY
- USAGE CALCULATOR
- WATT DETECTOR
- ENERGY ADVISOR



**A PLAN TO CONSERVE ENERGY AND LOWER UTILITY BILLS CAN START ANYWHERE, ANYTIME**  
 As your trusted energy partner, OPPD wants to empower you to take control of your energy use. This interactive floor plan lets you to choose where you would like to start your journey toward a more energy-efficient way of living -- and a lower electricity bill.

**Attic, Garage and Insulation**  
 Wondering how to save money on electricity bills? It starts with insulation throughout your home -- especially in the attic. Insulation is measured by R-value. The higher the value, the better the insulation is at preventing the flow of heat from space to space. Follow these tips for conserving energy and watch this video to learn more.

1. Blow-in, loose-fit insulation is best for attics. The insulation should pile up high enough to cover the tops of the ceiling joists (on the "floor" of the attic) plus a few inches.
2. Polyethylene- or neoprene-foam pipe sleeves are commonly used to insulate the cold and hot water pipes coming off the water heater. This can reduce the loss of convective heat through the hot and cold pipes near the tank.
3. Be sure to insulate rim joists using batt or rigid foam board insulation.
4. Insulate the attic hatch by using batt insulation and by adding weatherstripping where the hatch meets the frame.
5. Install weatherstripping on windows and exterior doors, including the door to an attached garage.
6. Consider installing plastic window covering on drafty windows.
7. Apply caulk to band joists and rim joists (the area that goes around the top perimeter of your basement) and other structural component gaps.
8. Install outlet and switch plate foam gasket seals for outlet and switch panels on exterior walls to help slow the flow of heat from those openings in the walls.

**Bedroom**  
 Your home consumes energy around the clock. Learn how to save on the electric bill even when you're sleeping.

1. Fans cool people, not rooms. Consider raising the temperature of the thermostat in the summer and using a fan to help cool you off as you sleep.
2. In the colder months, a ceiling fan spinning clockwise and on low can help distribute warm air more evenly in a room that may otherwise have cold spots.
3. Blackout curtains can not only help you sleep better, they can also help block the heat from the sun in the summer, keeping your bedroom cooler.
4. Close any doors that attach to the bedroom such as a closet or bathroom. This reduces the size of the space needed for heating or cooling.
5. In summer, stay cooler with breathable linens, then, in the winter, switch to a heavier style of linens and comforter. Any opportunity to cool off or warm up before touching the thermostat is a movement towards saving energy.
6. Electronic devices such as computers, monitors and even televisions can add heat to your bedroom causing a potentially uncomfortable temperature. Consider removing any electronic devices from your bedroom to help maintain the temperature.

# Energy Efficiency Webpages & Presentations



## New Webpages

- Annual updates to the information: new tips, updated tips, more cost-oriented tips
- ~64,000 site visits in 2020 (41% → interactive house)
- New Phantom Load video
- 3,440 views on EE videos



## Presentations

- Six Presentations to 220 customers (four in-person, two virtual)
- Presented for: Lewis & Clark Junior High science students, FHAS Post-Purchase Workshop, Bellevue Elementary

### Agenda

- Efficiency vs. Conservation
- Insulation
- Lights
- HVAC
- Resources
- Income-Qualified EE Pilot



# Celebrating 500 Customer-Owned Generation Interconnection Applications

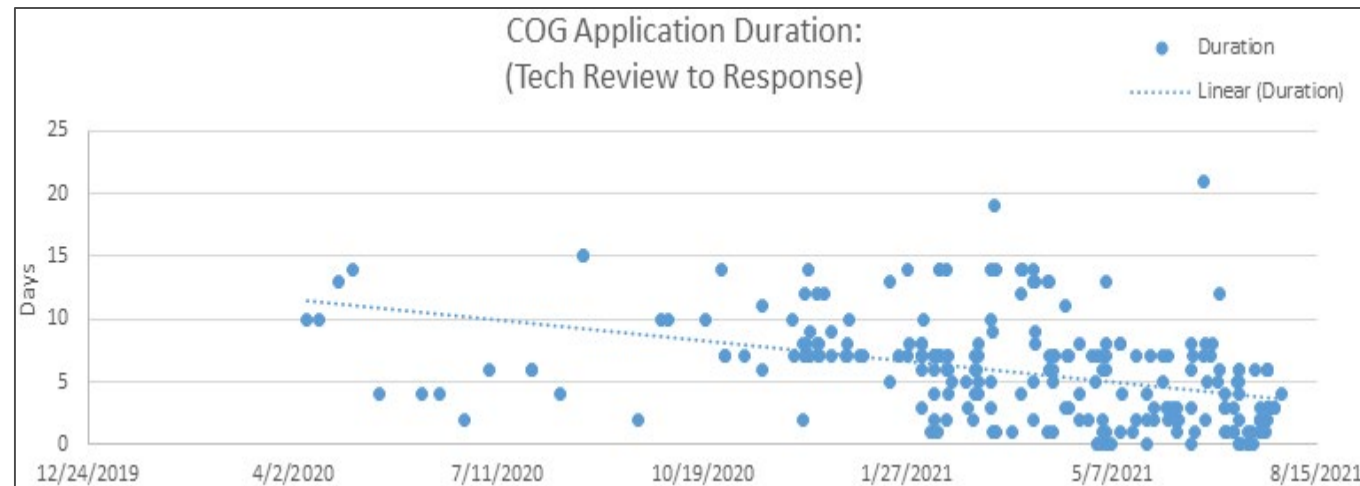


[OPPD.com/COG](http://OPPD.com/COG)

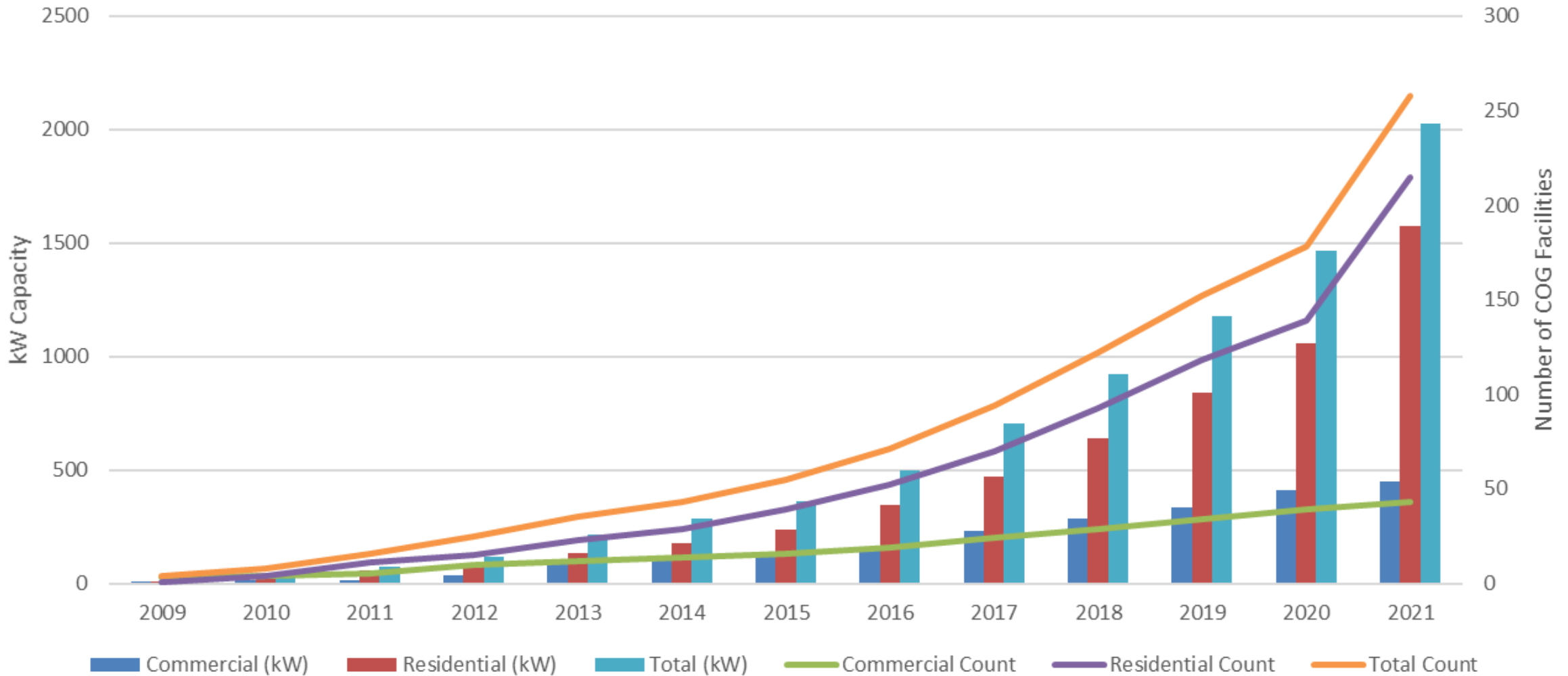
# Customer-Owned Generation Increases



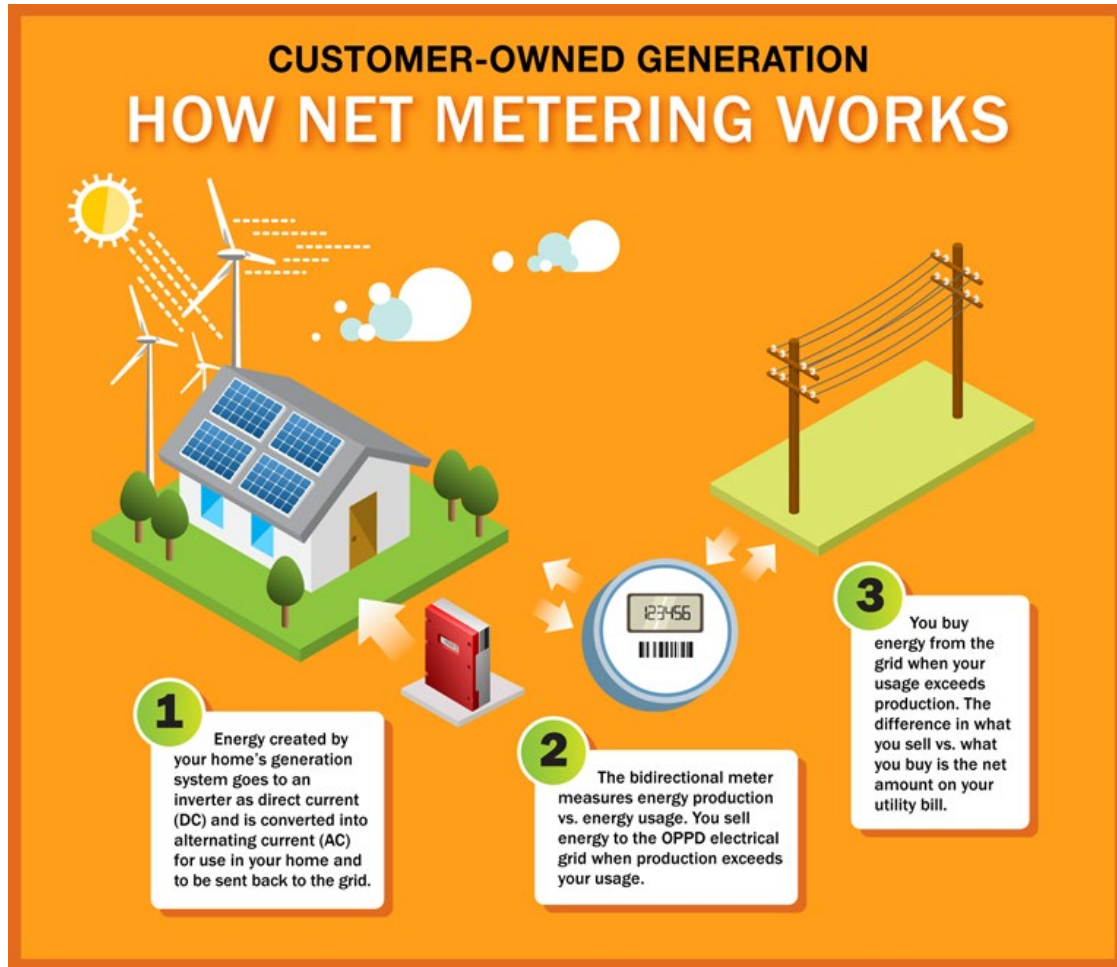
- OPPD received 500th application
- 500% Year over year Increase in applications
- 350 vs 59 applications
- 203 solar systems now online
- (157 Residential / 46 Commercial)
- 3,265 kW AC solar capacity
- Targeted marketing to educate customers



# Growth in Customer-Owned Generation (25 kW or Less)



# Net Metering Changes (Schedule 483)



## What Changed:

- Clarified size basis on 25 kW limit to be AC nameplate capacity.
- Increased size limit from 25 kW to 100 kW

## Benefits:

- Increased options for customers
- Decreased load during periods of strong solar generation
- Increased levels of local renewable energy in support of environmental goals

# Alternative Energy Technology Customer Education



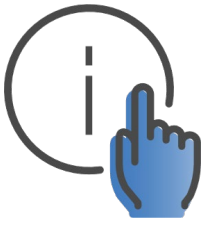
## Virtual and In-Person Presentations

- Careers in Energy
- Alternative Energy 101
- Battery Storage Overview
- Power with Purpose Solar
- Community Solar

## Presentations to:

- Nebraska Wind & Solar Conference
- Methodist Hospital
- Institute of Electrical and Electronics Engineers (IEEE)
- Society of Engineers
- Optimist Club
- Nebraskans for Solar

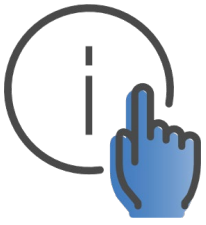




# Educate, Protect & Promote

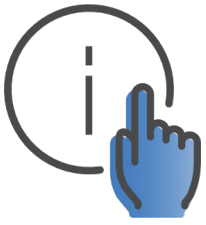
Advocate and educate local, state, and federal governments to protect and promote OPPD's environmental impact.





# Education Initiatives

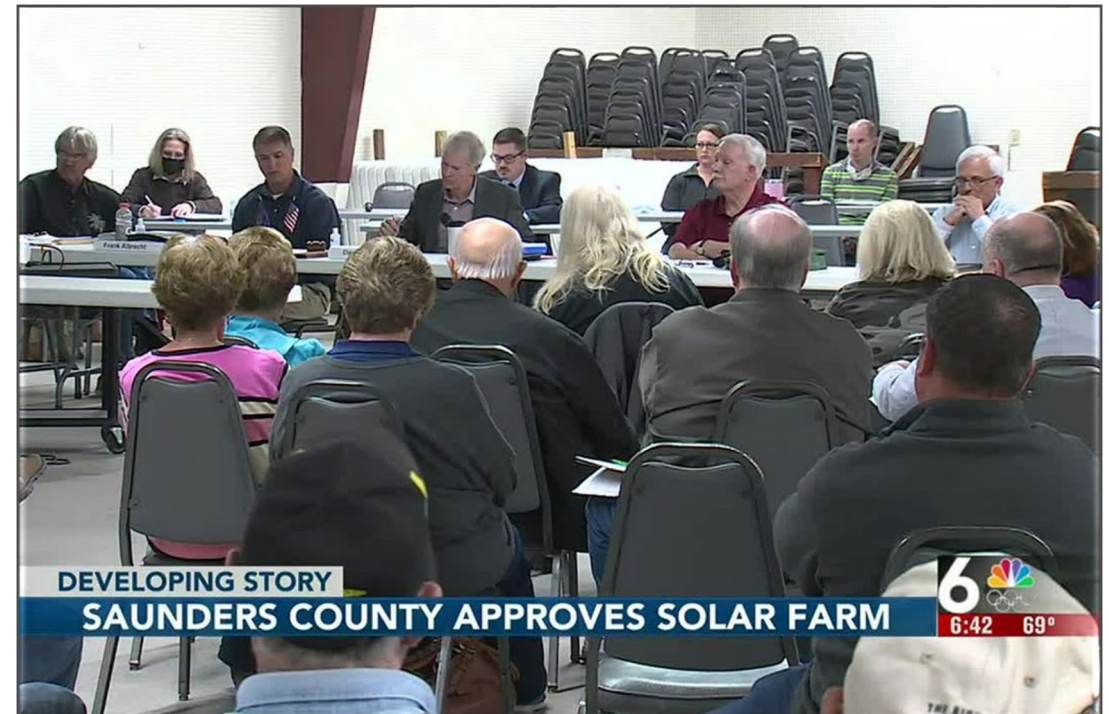
- Provided letters and **testimony to support operational environment for solar** in various jurisdictions:
  - Papillion
  - Springfield
  - Gretna
  - Bellevue
  - Burt County
  - Cass County
  - Sarpy County
  - Saunders County
  - Washington County
- Promoted **speaker's bureau education to policymakers on renewable energy topics** including sustainability and environmental plans:
  - Electric Vehicles
  - Decarbonization Plan
  - Solar
  - OPPD's Strategic Initiatives
  - Battery Storage
  - Renewable Energy Portfolio
  - Grant Opportunities
  - BRIGHT Project
- Attended AltEn (Mead, NE) **meetings to assess downstream political impacts on Platteview Solar Project.**
- Attended **Ft. Calhoun** town hall to discuss **Community Solar installation** and provide updates on repairs.
- Through **Metro Smart Cities Initiative, support the City of Omaha Climate Action Plan** development.



# Education Initiatives

- **Solar zoning regulation presentations** to various elected officials and community leaders:
  - Sarpy County Commissioners
  - Sarpy County Wastewater Agency Representatives (Mayors of five Sarpy Cities)
  - City Administrators (Bellevue, La Vista, Papillion, Springfield, Gretna)
  - Gretna City Council members
  - Springfield Planning Commissioners
  - Springfield City Councilmembers
  - Bellevue City Council
  - Bellevue Planning Commission
  - Burt County Planning Commission
  - Burt County Board of Supervisors
  - Washington County Board of Supervisors
  - Dodge County Board of Supervisors

- Platteview Solar team presenting **“Shining a Light on Solar”** at **Nebraska Planning Zoning Conference**, September 2021



# Recommendation

The System Management Committee has reviewed and accepted this Monitoring Report for SD-7 and recommends that the Board find OPPD to be sufficiently in compliance with Board Policy SD-7.



Williams/Fisher

**DRAFT**  
**RESOLUTION NO. 64xx**

**WHEREAS**, the Board of Directors has determined it is in the best interest of the District, its employees, and its customer-owners to establish written policies that describe and document OPPD's corporate governance principles and procedures; and

**WHEREAS**, each policy was evaluated and assigned to the appropriate Board Committee for oversight of the monitoring process; and

**WHEREAS**, the Board's System Management and Nuclear Oversight Committee (the "Committee") is responsible for evaluating Board Policy SD-7: Environmental Stewardship on an annual basis. The Committee has reviewed the 2021 SD-7: Environmental Stewardship Monitoring Report and finds OPPD to be sufficiently in compliance with the policy as stated.

**NOW, THEREFORE, BE IT RESOLVED** that the Board of Directors of Omaha Public Power District accepts the 2021 SD-7: Environmental Stewardship Monitoring Report, in the form as set forth on Exhibit A attached hereto and made a part hereof, and finds OPPD to be sufficiently in compliance with the policy as stated.



## Pre-Committee Agenda

### PUBLIC INFORMATION PRE-COMMITTEE MEETING WEBEX VIDEOCONFERENCE

Tuesday, October 12, 2021 4:00 – 5:15 P.M.

1. Legislative and Regulatory Update (20 min)
  - a. Objective: Provide brief update on federal and state legislative and regulatory activities
2. SD-13: Stakeholder Outreach and Engagement Monitoring Report (30 min)
  - a. Objective: Provide brief update on monitoring report
3. Green Power Program Update (10 min)
  - a. Objective: Provide brief update on Green Power Program
4. Confirmation of Board Work Plan – Public Information Committee Items (10 min)
  - a. Objective: Discuss Public Information Committee items on the Board work plan
5. Summary of Committee Direction (5 min)
  - a. Objective: Executive leadership team liaison(s) to summarize direction provided by the committee



# Reporting Item

## BOARD OF DIRECTORS

October 19, 2021

### ITEM

Customer Trends Update *[Note: Not presented due to time. Update posted on oppd.com.]*

### PURPOSE

To provide a quarterly update on customer trends and energy assistance

### FACTS

1. The Board requested that management provide regular reports on the progress of customer programs and trends.
2. Customer accounts receivable balances have normalized in 2021.
3. Management will provide an update on aged debt and related trends as of September 30, 2021.

### RECOMMENDED:

DocuSigned by:

*Juli A. Comstock*

2D585D99131647A...

Juli A. Comstock

Vice President – Customer Service

### APPROVED FOR REPORTING TO BOARD:

DocuSigned by:

*L. Javier Fernandez*

AC399FDCE56247E...

L. Javier Fernandez

President and Chief Executive Officer

JAC:rak



# Customer Trends Quarterly Update

as of September 30, 2021

All Committee Meeting October 19, 2021



Continuing to monitor and adjust OPPD's solutions as our customers' needs are changing.



## Summary of Q3 Customer First Solutions

- Maintain flexible bill payment options to help customers financially
- Automatically waive collection & reconnect fees on first field visit in 2021
- Empower customer service representatives to waive up to 3 late payment charges for a customer in a 12-month period
  - Additional fees may be waived upon approval and customer request (e.g. late payments, return check fees, collection & reconnect fees, etc..)
- Suspend assessing additional deposits due to field collection visits
- Small Mid Business customers will continue to receive personalized collection efforts prior to disconnection
- Continue personalized field visits and outreach to ensure impacted customers are aware of their options (via Connecting with Customers effort)



## Energy Assistance

- OPPD received \$735,569 for Cooling Supplemental benefits for 4,896 customers in September



## Promotional/Marketing Campaign

- OPPD continues to partner with school districts to provide families financial and energy assistance options



## Next Steps

- Monitor current pandemic trends for possible adjustment of Customer First Solutions to determine what customer solutions will carry into 2022

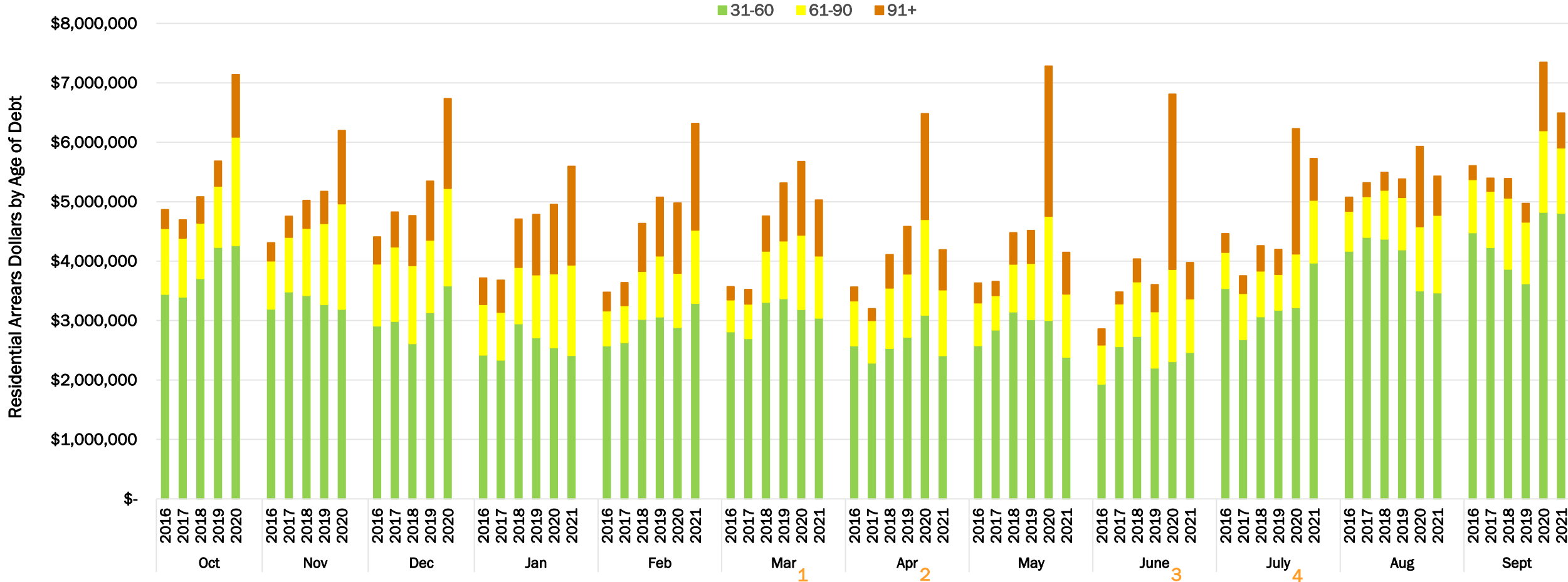


# Summary of Aged Debt

	Residential			Commercial & Industrial		
	September 2021	September 2020	% Change	September 2021	September 2020	% Change
% of Accounts Current	89.7%	89.6%	0.1% ↑	92.9%	92.5%	1.2% ↑
% of Accounts in Arrears	10.3%	10.4%	-1.0% ↓	7.1%	7.5%	-14.7% ↓
Total Aged Debt > 30 days (in millions)	\$6.5	\$7.3	-11.6% ↓	\$1.8	\$2.6	-32.6% ↓
Total Aged Debt 91+ Days (in millions)	\$0.6	\$1.1	-48.8% ↓	\$0.2	\$0.3	-22.2% ↓
Total Service Agreement Count > 30 Days (in thousands)	38.0	39.6	-4.0% ↓	2.0	2.2	-10.1% ↓
Total Service Agreement Count > 91+ Days (in thousands)	5.3	5.8	-8.3% ↓	0.3	0.5	-30.3% ↓

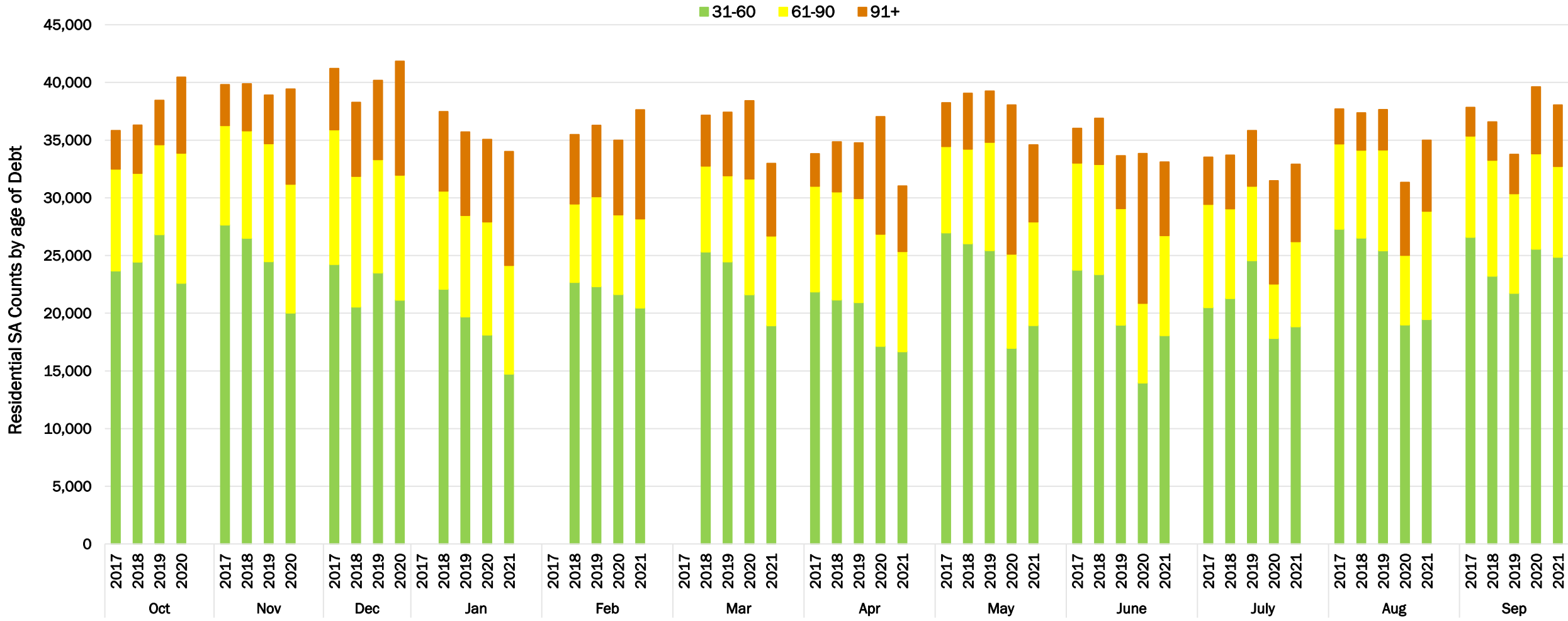
LIHEAP Only Accounts	September 2021	September 2020	% Change
% of Accounts Current	83%	83%	0%
% of Accounts in Arrears	17%	17%	0%
Total Aged Debt > 30 days (in millions)	\$0.5	\$0.6	-16.9% ↓
Total Aged Debt 91+ Days (in millions)	\$0.05	\$0.1	-62.1% ↓
Total Service Agreement Count > 30 Days (in thousands)	2.4	2.3	6.3% ↑
Total Service Agreement Count > 91+ Days (in thousands)	0.4	0.6	-23.8% ↓

# Residential Arrears Dollars by Age of Debt Active Accounts



- 1 Announced suspension of disconnects for non-payment due to COVID-19
- 2 Announced suspension of Late Payment Charges
- 3 Announced reinstatement of Late Payment Charges and disconnects for non-payment beginning in July
- 4 Resumed assessment of Late Payment Charges and disconnects for non-payment

# Residential Counts by Age of Debt Active Accounts



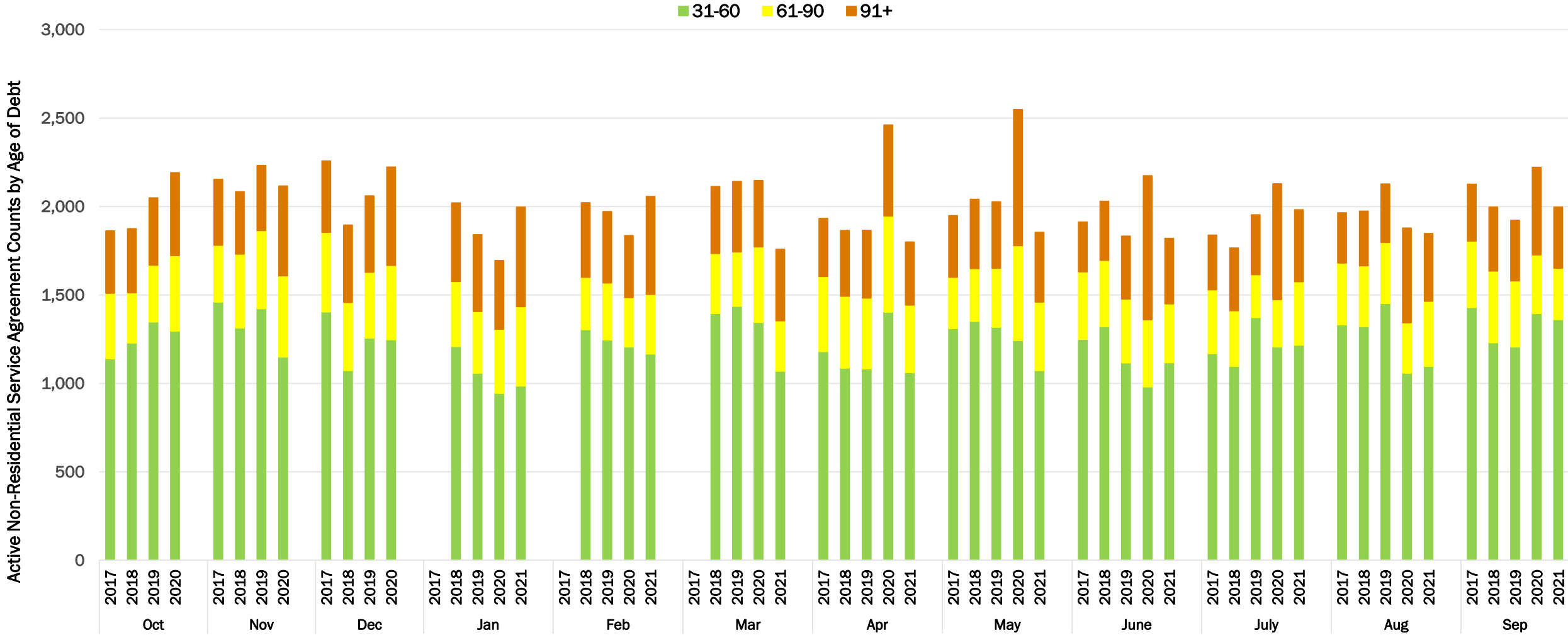
\*Jan. - March 2017 data not available

# Commercial & Industrial Arrears Dollars by Age of Debt Active Accounts



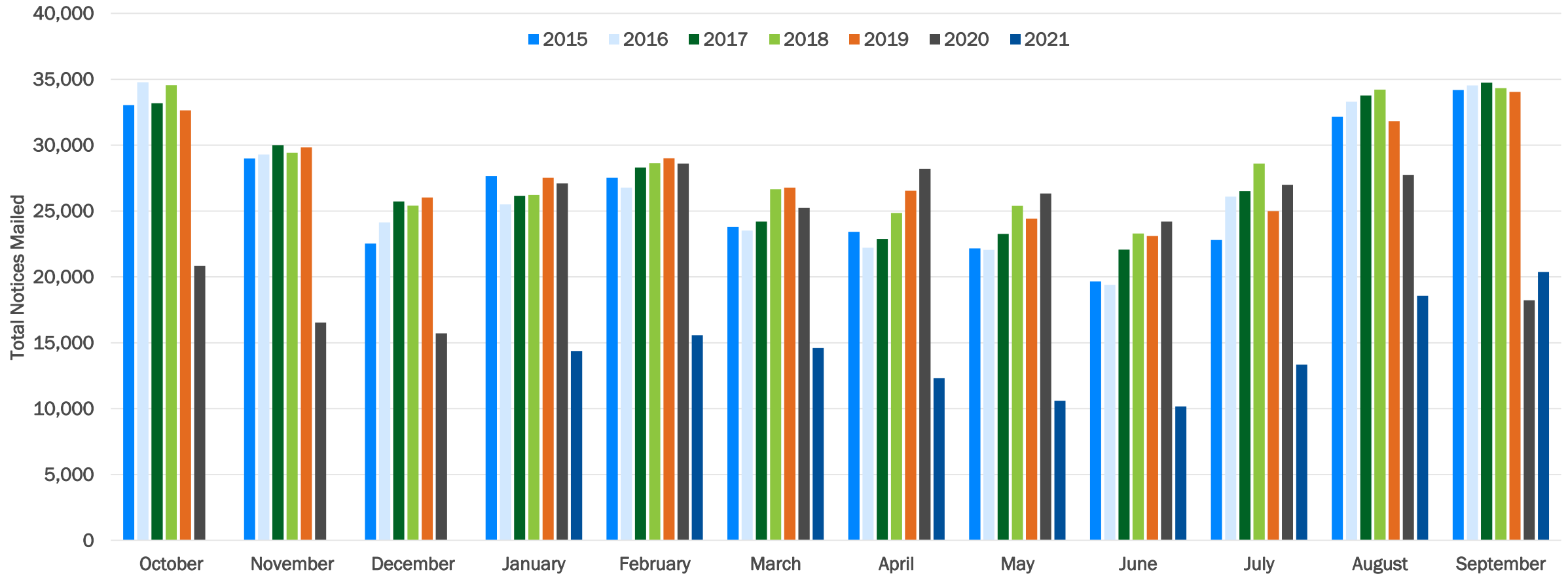
- 1 Announced suspension of disconnects for non-payment due to COVID-19
- 2 Announced suspension of Late Payment Charges
- 3 Announced reinstatement of Late Payment Charges and disconnects for non-payment beginning in July
- 4 Resumed assessment of Late Payment Charges and disconnects for non-payment

# Commercial & Industrial Counts by Age of Debt Active Accounts



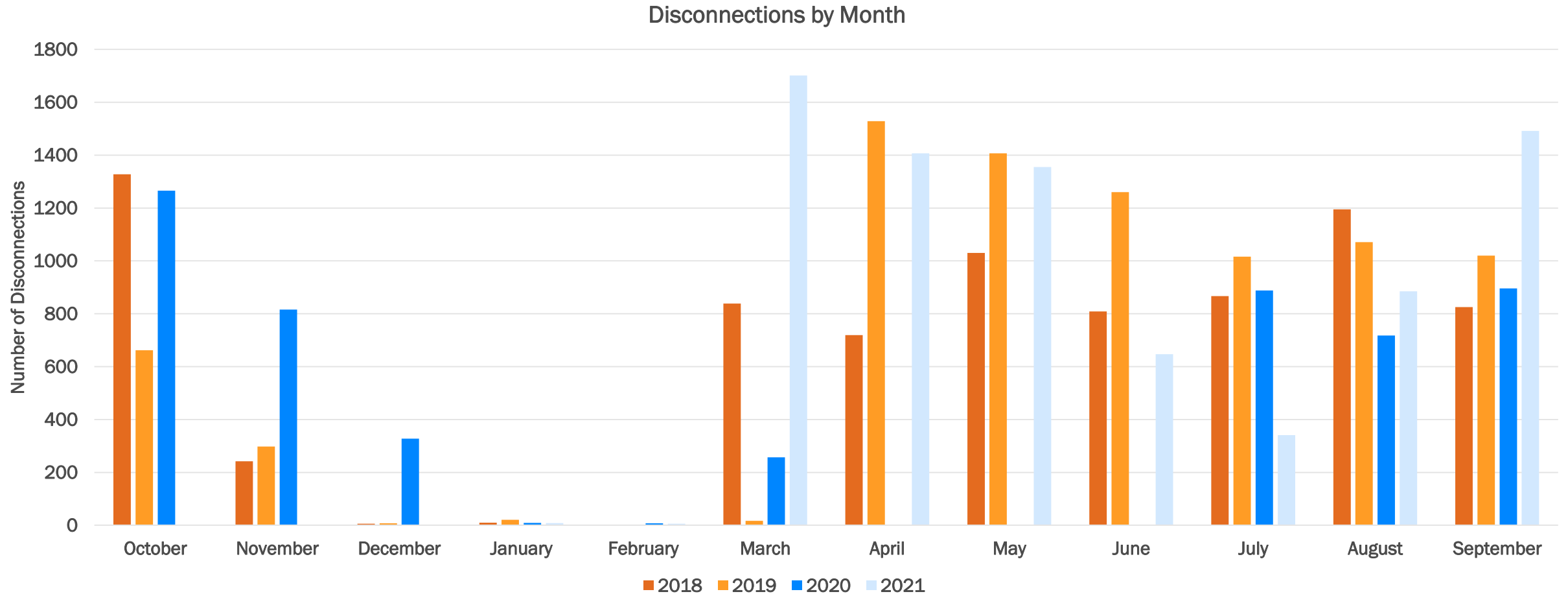
\*Jan. - March 2017 data not available

# Disconnect Notices Issued



Note: Historically, a Disconnect Notice was issued to a customer at the time of billing if the past due amount was > \$100 and the customer has not demonstrated a good payment history. During the latter portion of March thru June 2020 a past due reminder letter replaced the Disconnect Notice since disconnects for non-payment were suspended during this time. The values during this period represent accounts that received a letter in lieu of a Disconnect Notice. Effective 8/25/2020, the threshold of the notice was set to > \$200 which will decrease the number of Disconnect Notices generated from that point forward.

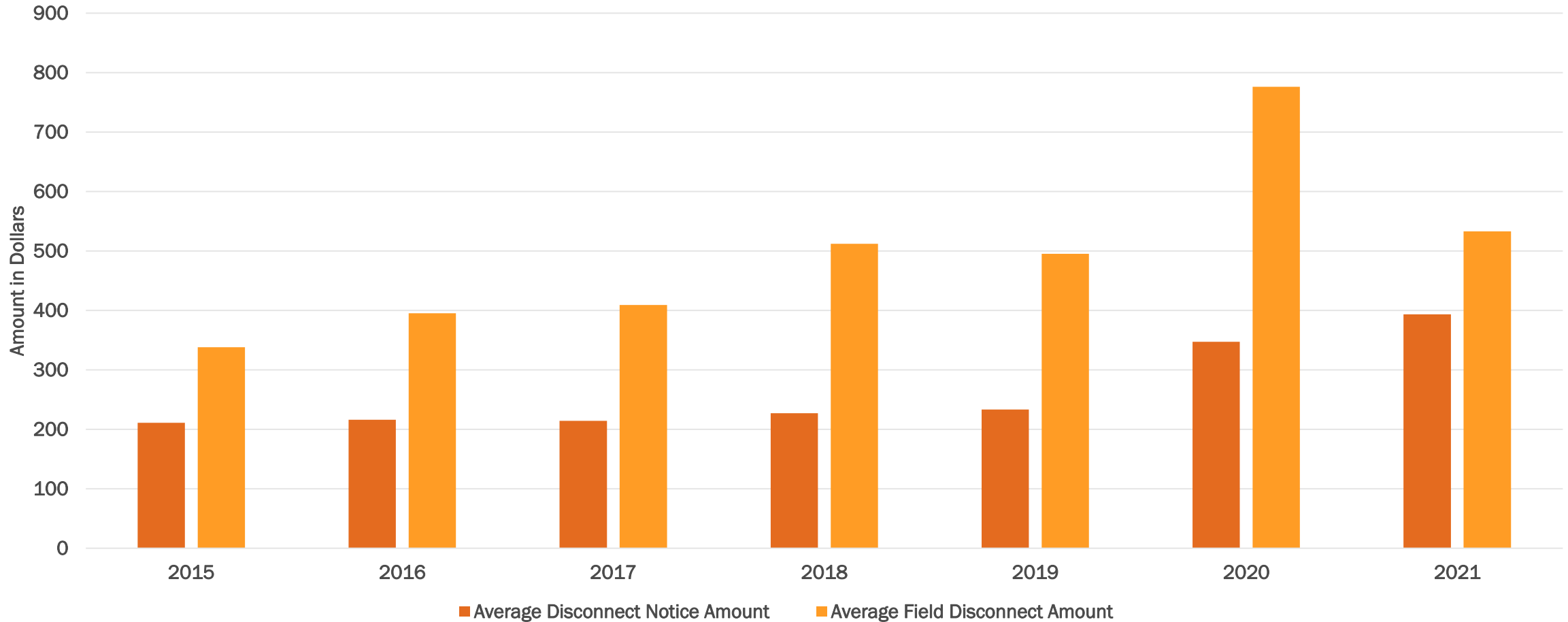
# Disconnections for Non-Payment by Month



In 2020 Disconnections for non-payment were suspended from early March to mid-July due to COVID-19.

# Average Disconnect Notice Amount vs Average Field Collection Amount

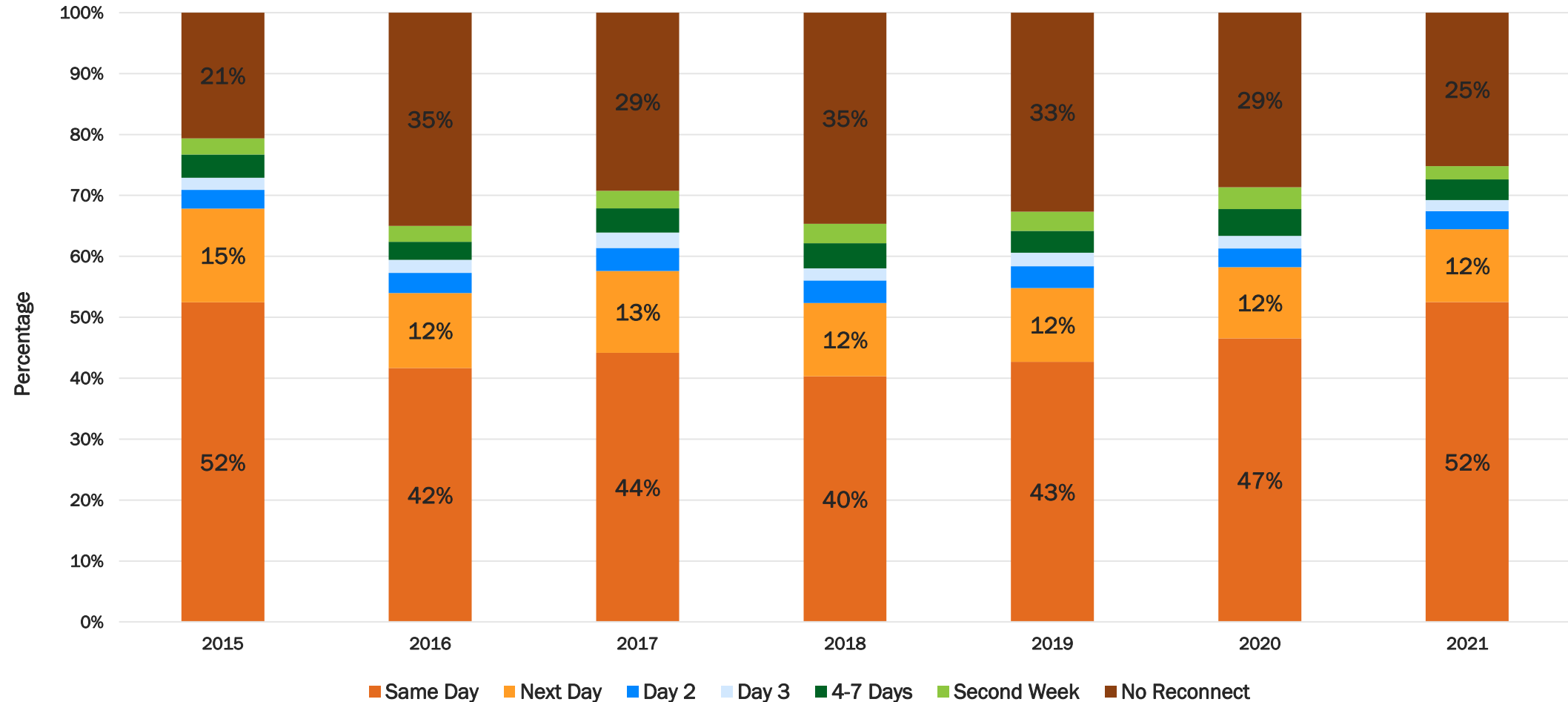
Average Disconnect Notice Amount vs Average Field Collection Amount



Note: OPPD prioritizes field collection and disconnection activities to the highest and riskiest debt which is reflected with the higher dollar value for orders sent to the field for collections/disconnection for non-payment vs the average disconnect notice amount.



# Timing of Reconnections after Disconnect for Non-Pay



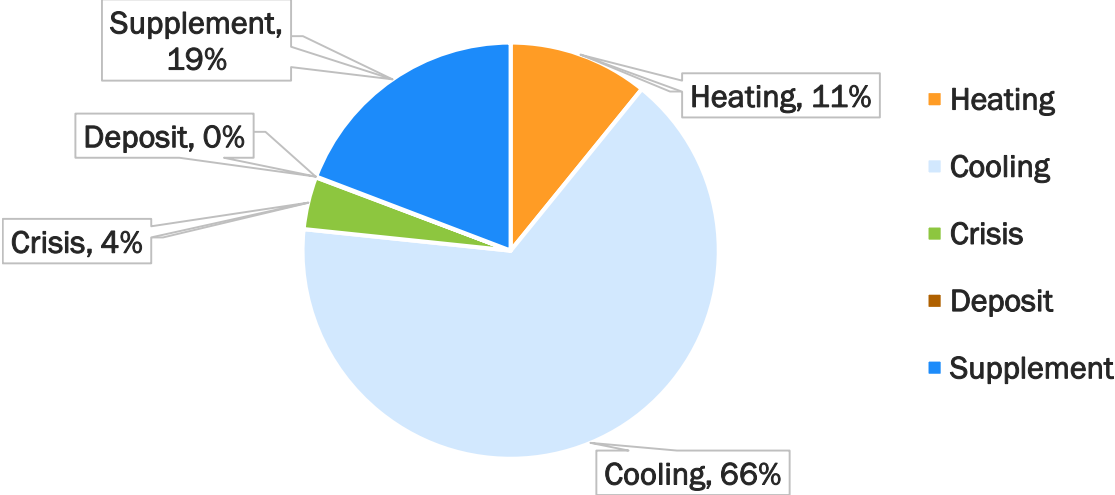
\*2021 Data is YTD

# Energy Assistance September 2021 YTD

Funding Source	September 2021 YTD	Average Benefit	Distinct Accounts	# of Payments	2020 Year End Total
Energy Assistance Program	\$209,550	\$313	669	669	\$377,571
COVID Relief Programs	\$1,635,315	\$363	3,795	4,419	\$1,641,914
LIHEAP	\$3,680,798	\$346	6,235	10,629	\$5,846,198
Other Agencies Assistance	\$2,090,422	\$304	5,509	6,871	\$1,489,902
<b>Total</b>	<b>\$7,616,085*</b>	<b>\$337</b>	<b>13,307</b>	<b>22,588</b>	<b>\$9,355,585</b>

\*YTD 2020, OPPD had received a total of \$5,959,691 in Energy Assistance Payments

## LIHEAP Distribution



Douglas County COVID-19 Utility Assistance Program	5/31/2021
Completed Applications*#	3,246
Approved Applications^	2,000
Average benefit	\$500
<b>Total Dollars Granted</b>	<b>\$1,000,000</b>

\*Total applications completed for the program.  
 #Electronic applications processed when program closed on 5/7/2021.  
 ^Customers approved for the Douglas County COVID-19 Utility Assistance Program.



# Reporting Item

## BOARD OF DIRECTORS

October 19, 2021

### ITEM

Legislative and Regulatory Update

### PURPOSE

To provide an update on 2021 state and federal legislative matters and regulatory matters

### FACTS

- a. Nebraska’s 107th Legislature began on January 6, 2021 and ended on May 27, 2021.
- b. The Special Session of the Nebraska Legislature for redistricting began on September 13, 2021 and ended on September 30, 2021.
- c. The 117<sup>th</sup> Congress began on January 3, 2021 and is expected to end January 3, 2023.


### ACTION

Reporting item

#### RECOMMENDED:

DocuSigned by:  
  
 46058A9ADE8A409...  
 Lisa A. Olson  
 Vice President – Public Affairs

#### APPROVED FOR REPORTING TO BOARD:

DocuSigned by:  
  
 AC399FDCE56247E...  
 L. Javier Fernandez  
 President and Chief Executive Officer

Attachment: State and Federal Legislative Update



# Government Affairs & Energy Regulation Update 10/19/2021

Tim O'Brien, Director – Economic Development & External Relations

Joe Lang – Energy Regulation

# Agenda

- Nebraska Power Review Board Meeting from Oct 15, 2021 - Debrief
- Nebraska Legislature Update
  - Legislative Resolution 136
  - 2021 Special Session
- Federal Update
- Q&A
- Appendix with Local, State and Federal Government Affairs Update

# Energy Regulation Update



# Regional and Neb. Power Review Board Activity

## Recent Activity

- Feb – Polar Vortex, SPP controlled outages
- Aug – Utility, SPP, PRB meeting with Ricketts
- Sep – PRB meetings with OPPD, NPPD, LES
- Oct –
  - PRB sent draft legislation
  - Coordination w Neb Power Association (NPA)
  - PRB meeting on 10/15/21

# Nebraska Power Review Board (PRB) Background

## PRB Primary Regulation Purpose

- Electric utility service territories
- Construction/acquisition of generation and transmission facilities

## Legislative History

- 2016 LB 824 – Exempted privately developed renewable gen facilities from PRB approval
  - Notice to PRB required



# Nebraska Power Review Board - Draft Legislation

## Generation Retirements

- Applicable to gen in excess of 10 MWs
- Electric supplier must provide PRB written notice prior to final decision
- PRB may hold a hearing in its discretion
- PRB shall make its recommendation whether decommissioning is in the best interests of the
  - Electric supplier, or
  - Electric customers

# Nebraska Power Review Board - Draft Legislation

## Power Purchase Agreements

- Approval required before an electric supplier enters or attempts to enter into a PPA
- Applicable to
  - PPAs for rights to electric energy
  - For a term greater than 1 yr

# State Legislative Update



# Legislative Resolution 136

- *Interim study to examine and evaluate the causes, costs, and impacts of rolling electrical power outages during the extreme weather events of February 2021*
- LR 136 hearing scheduled – Oct 29, 2021 @ 1:00 (notified on Oct 6)
  - Open to the Public, Invited Testimony Only
  - Board Chairs are invited to testify on behalf of utilities
- OPPD is coordinating with the Nebraska Power Association

# 2021 Special Session

- Convened on September 13<sup>th</sup> - Sine Die September 30<sup>th</sup>
- The Committee held hearings in the 3 congressional districts
- After much debate, the maps were redesigned from the original version  
Below are the links to the maps
  - Congress - LB1
    - [http://news.legislature.ne.gov/red/files/2021/09/CONG21-39002\\_SIGNED.pdf](http://news.legislature.ne.gov/red/files/2021/09/CONG21-39002_SIGNED.pdf)
    - [http://news.legislature.ne.gov/red/files/2021/09/CONG21-39002-1\\_SIGNED.pdf](http://news.legislature.ne.gov/red/files/2021/09/CONG21-39002-1_SIGNED.pdf)
    - [http://news.legislature.ne.gov/red/files/2021/09/CONG21-39002-2\\_SIGNED.pdf](http://news.legislature.ne.gov/red/files/2021/09/CONG21-39002-2_SIGNED.pdf)
    - [http://news.legislature.ne.gov/red/files/2021/09/CONG21-39002-3\\_SIGNED.pdf](http://news.legislature.ne.gov/red/files/2021/09/CONG21-39002-3_SIGNED.pdf)
  - Nebraska Legislature - LB3
    - [http://news.legislature.ne.gov/red/files/2021/09/LEG21-39006\\_signed.pdf](http://news.legislature.ne.gov/red/files/2021/09/LEG21-39006_signed.pdf)
    - <http://news.legislature.ne.gov/red/adopted-plan/leg21-39006-map-book/>

# Federal Legislative Update



# Federal Update Summary

- Bipartisan infrastructure package, debt ceiling, and budget reconciliation packages is the focus
  - The bipartisan \$1.2 trillion, infrastructure package (H.R. 3684) passed Senate 69-30 on August 10<sup>th</sup>. Still waiting for a floor vote in the House.
  - House approved a \$480 billion debt ceiling increase to avoid a breach of the nation's borrowing limit until at least Dec. 3, when government funding is also set to expire.
  - House Committees markup for \$3.5 trillion budget reconciliation completed. Senate still negotiating on top-line number and policies to be included.
  - OPPD engaged with American Public Power Association and Large Public Power Council; NE Congressional Delegation; Committee staff; and other Members of Congress on the Committees of Jurisdiction.
  - Closely monitoring the Clean Electricity Payment Program (CEPP), Investment Tax Credits/Production Tax Credits (with direct payment), restoration of advanced refunding, EV incentives and many others
  - ***New deadline for vote in the House is October 31<sup>st</sup>***
- 8,436 bills introduced in the 117<sup>th</sup> Congress as of October 7<sup>th</sup>

SOURCE Congress.gov, Politico, Whitehouse.gov

# Appendix



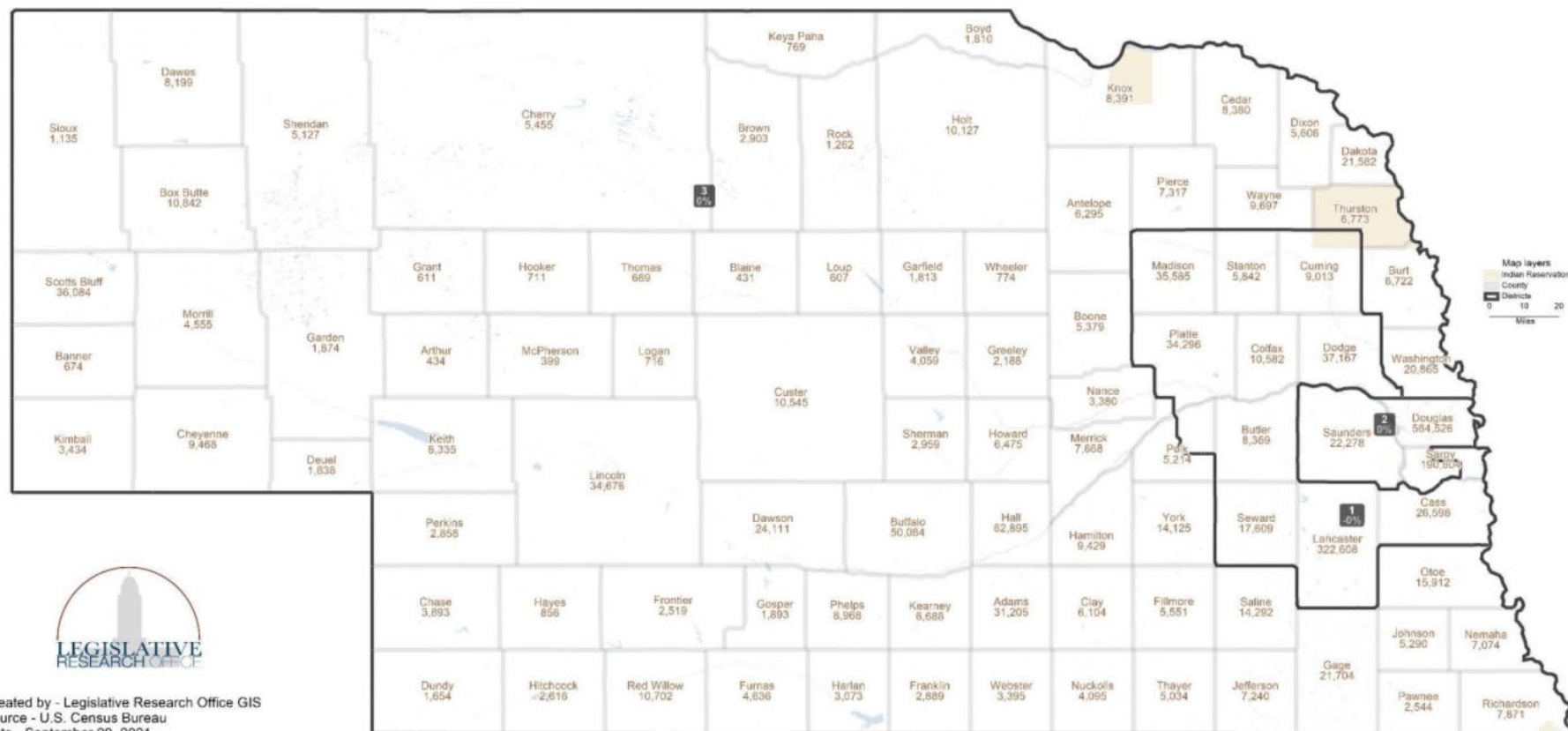


# State Legislative Update



# Congress- LB1

United States House of Representatives - LB1 - Final Reading (2021)  
CONG21-39002



Created by - Legislative Research Office GIS  
 Source - U.S. Census Bureau  
 Date - September 29, 2021  
 CONG21-39002

©2021 CALIPER



# 2021 Legislative Resolutions - Interim Studies

LR & Current Status	Summary
LR 23 Erdman	Interim study to examine the progress of natural resources districts in fulfilling their originally intended purpose. Includes a study of flood control
	<i>5/20/21 Referred to Natural Resources Committee</i>
LR 34 Slama	Interim study to examine the structure and funding of the Nebraska Environmental Trust. OPPD has received \$600,000 for battery storage, butterfly and EV charging station grants over the years
	<i>5/20/21 Referred to Natural Resources Committee</i>
LR 83 M. Hansen	Interim study to examine the gubernatorial appointment process of members to boards, commissions and similar entities
	<i>5/20/21 Referred to Executive Board, 10/20/21 Hearing scheduled</i>
LR 102 Wishart	Provide the Legislature take steps to combat the climate and ecological crisis
	<i>4/22/21 Referred to Natural Resources Committee</i>
LR 106 Kolterman	Interim Study to monitor underfunded defined benefit plans administered by political subdivisions as required by 13-2402.
	<i>5/20/21 Referred to Nebraska Retirement Systems Committee. 11/5/21 Hearing scheduled</i>

# 2021 Legislative Resolutions - Interim Studies

LR & Current Status	Summary
LR 136 Brewer	Interim Study to examine and evaluate the causes, costs, and impacts of rolling electrical power outages during the extreme weather events of February 2021
	<i>5/20/21 Referred to Natural Resources Committee, 10/29/21 hearing scheduled</i>
LR 147 J. Cavanaugh	Interim study to examine the transfer of state-owned property to local political subdivisions
	<i>5/20/21 Referred to Transportation and Telecommunications Committee</i>
LR 170 McKinney	Interim study to examine the potential impact that innovation hubs could have in Nebraska
	<i>5/20/21 Referred to Business and Labor Committee. 8/11/21 hearing held</i>
LR 178 Wishart	Interim study to solicit input from Nebraskans regarding funds from the federal American Rescue Plan act of 2021
	<i>5/20/21 Referred to Appropriations Committee, 10/5/21 hearing held</i>
LR 179 M. Cavanaugh	Interim study to examine funding mechanisms in the American Rescue Plan Act of 2021
	<i>5/20/21 Referred to Appropriations Committee, 10/5/21 hearing held</i>

# 2021 Legislative Resolutions - Interim Studies

LR & Current Status	Summary
LR 193 De Boer	Interim study to examine broadband mapping and broadband speed testing in Nebraska
	<i>5/20/21 Referred to Transportation and Telecommunications Committee</i>
LR 199 Slama	Interim study to examine the creation of rural economic development program
	<i>5/20/21 Referred to Banking, Commerce and Insurance Committee</i>
LR 202 HHS Committee	Interim study to examine federal legislation regarding COVID-19 pandemic assistance
	<i>5/20/21 Referred to HHS Committee</i>
LR 211 Lowe	Interim study to examine issues related to adopting construction codes
	<i>5/20/21 Referred to Urban Affairs Committee, Hearing held 8/6/21</i>
LR 234 Friesen	Interim study to examine issues related to the regulation and taxation of electric vehicles
	<i>5/20/21 Referred to Transportation and Telecommunication Committee</i>
LR 246 NR Committee	Interim study to examine issues within the jurisdiction of the Natural Resources Committee
	<i>5/26/21 Referred to Natural Resources Committee</i>

# Local Legislative Update



# Local Legislation/Events

- Bellevue City Council passed solar regulations on October 5. OPPD was asked to provide expert testimony and guidance on the creation of the regulations.
- Since July, OPPD SMEs presented pathways for Douglas County to achieve energy efficiency and sustainability through:
  - Incorporating EVs into Douglas County’s fleet;
  - Building optimization & energy efficiency;
  - Supporting distributed generation; and
  - Addressing the water-energy nexus



# Local Legislation/Events

- Fourteen people applied to fill the vacancy in District 1 of the Douglas County Board from Mike Boyle's passing. The Appointment Committee will hold two upcoming meetings on that selection on Oct. 13 & 22.

# Federal Legislative Update



# Breakdown of Democrats' \$3.5 trillion budget resolution to the American Jobs Plan



Overview of the budget resolution



Current arguments and forecast for the bills

## OVERVIEW OF SENATE DEMOCRATS' RESOLUTION

Senate Majority Leader Schumer (D-NY) released reconciliation instructions for Senate committees to draft the details of the spending bill. The resolution currently allocates the following funds to each committee:

- Health, Education, Labor, and Pensions: **\$726 billion**
- Banking: **\$332 billion**
- Energy: **\$198 billion**
- Agriculture: **\$135 billion**
- Judiciary: **\$107 billion**
- Commerce: **\$83 billion**
- Environment and Public Works: **\$67 billion**
- Homeland Security: **\$37 billion**
- Small Business: **\$25 billion**
- Indian Affairs: **\$20.5 billion**
- Veterans Affairs: **\$18 billion**
- Finance: **~\$1 billion**

Within the resolution, committees submitted draft legislation by September 15<sup>th</sup>

Concerns exist about the resolution's inability to raise the debt ceiling, but Democrats aim to pay for the plan through corporate and individual tax reform and increased IRS enforcement of existing rates. Senators Warren (D-MA) and King (I-ME) are also prepared to introduce a 7% tax on corporate profits over \$100 million, expecting to raise \$700 billion from 1,300 companies



# Board Action

## BOARD OF DIRECTORS

October 19, 2021

### ITEM

SD-13: Stakeholder Outreach and Engagement Monitoring Report

### PURPOSE

To ensure full Board review, discussion and acceptance of SD-13: Stakeholder Outreach and Engagement Monitoring Report.

### FACTS

- a. The first set of Board policies was approved by the Board on July 16, 2015. A second set of Board policies was approved by the Board on October 15, 2015.
- b. Each policy was evaluated and assigned to the appropriate Board Committee for oversight of the monitoring process.
- c. The Public Information Committee is responsible for evaluating Board Policy SD-13: Stakeholder Outreach and Engagement.
- d. The Public Information Committee has reviewed the SD-13: Stakeholder Outreach and Engagement Monitoring Report, as outlined on Exhibit A, and is recommending that OPPD be found to be sufficiently in compliance with the policy as stated.


### ACTION

The Public Information Committee recommends Board approval of the 2021 SD-13: Stakeholder Outreach and Engagement Monitoring Report.

#### RECOMMENDED:

DocuSigned by:  
  
 46058A9ADE8A409  
 \_\_\_\_\_  
 Lisa A. Olson  
 Vice President – Public Affairs

#### APPROVED FOR BOARD CONSIDERATION:

DocuSigned by:  
  
 AC399FDCE56247E...  
 \_\_\_\_\_  
 L. Javier Fernandez  
 President and Chief Executive Officer

LAO:mfh

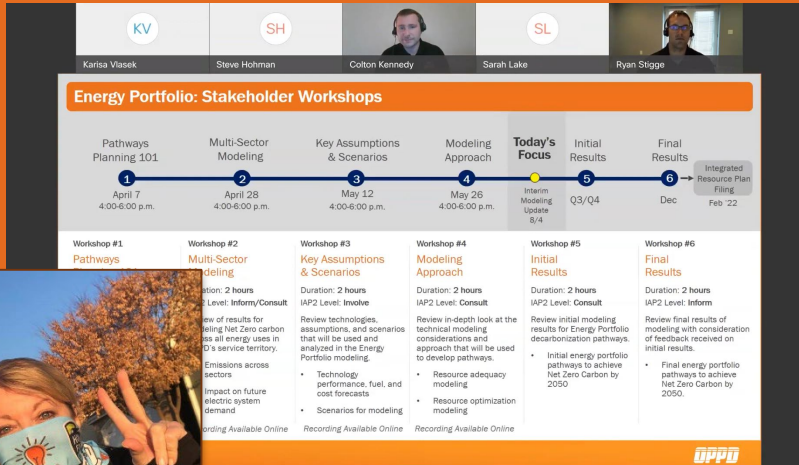
Attachments:  
Exhibit A – Monitoring Report  
Resolution

# Monitoring Report: SD13: Stakeholder Outreach & Engagement Public Information Committee

October 19, 2021

Lisa Olson, Vice President – Public Affairs

# Another historic year and it accelerated our growth



**ONLINE WORKSHOPS**

**Decarbonization: Energy Portfolio Online Workshops**

Recordings of all past workshops and updates are available to view. In addition, a summary video of past workshops is also available.

[Read more](#)



**“Power with Purpose” Community Meeting**  
South 168<sup>th</sup> Street & Fairview Road  
Tuesday, Sept. 29, 2020  
6-7 p.m.

Thank you for joining us!  
We look forward to sharing more information with you and answering your questions during the Q & A period.

*Please note this meeting will be recorded and posted later at [OPPDPCommunityConnect.com](http://OPPDPCommunityConnect.com).*

# SD-13: Stakeholder Outreach & Engagement

As a publicly owned utility, OPPD is committed to engaging its customers, the community and other stakeholders.\* OPPD shall:



- **Use an integrated, clear and transparent engagement process that:**
  - Provides meaningful ways for customer-owners to participate and provide feedback.
  - Is representative of the interested and impacted customer-owner segments that OPPD serves.



- **Share context with customer-owners around key decisions.**



- **Continuously evaluate and improve its outreach and engagement processes.**

# OPPD's outreach work has rapidly intensified in volume and complexity, and our approach has matured along the way

## 2016

- 1. Integrated Resource Planning
- 2. Generation Options – Fort Calhoun

## 2017

- 1. Community Solar
- 2. Sarpy & La Vista Transmission Projects

## 2018

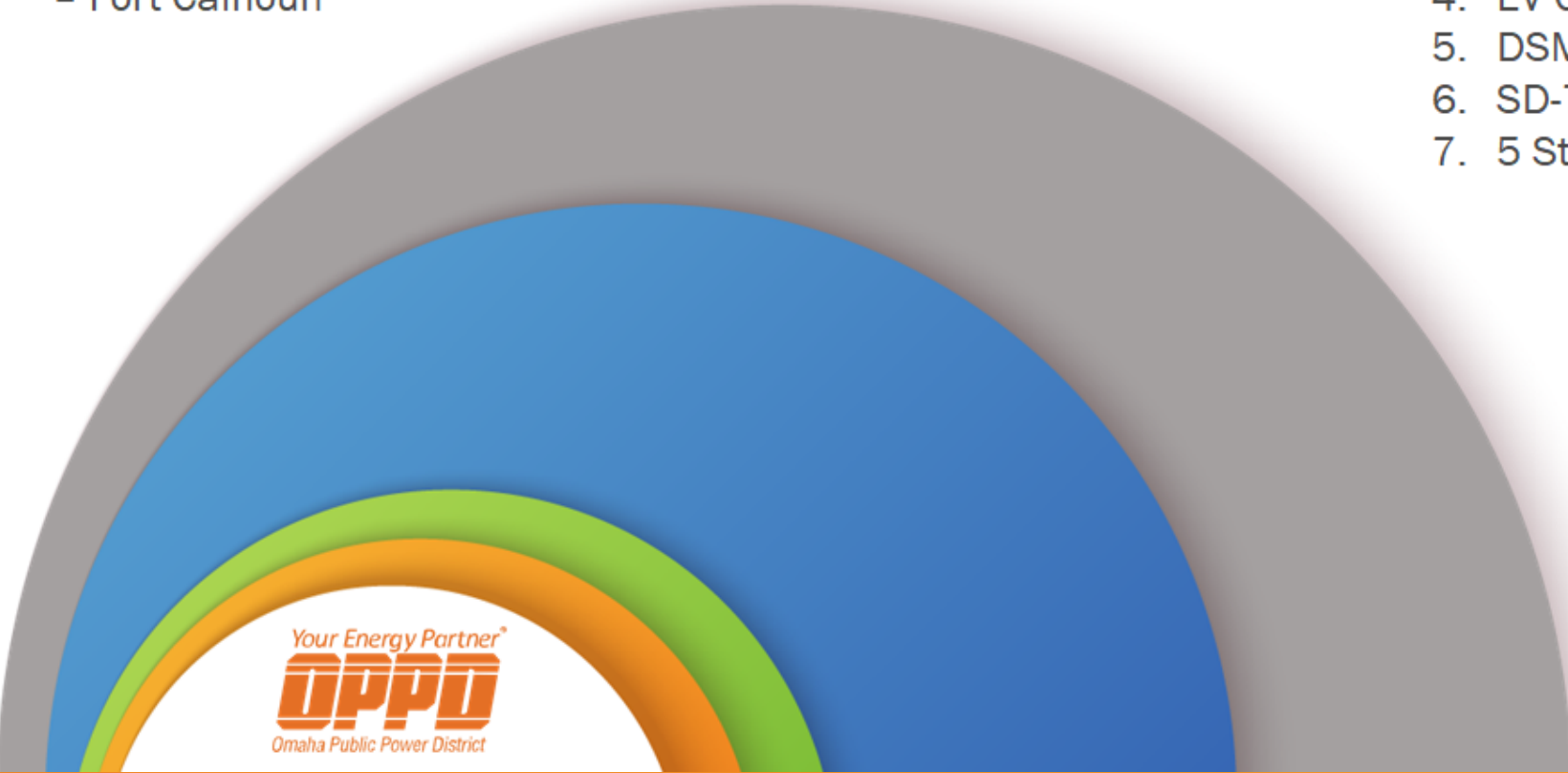
- 1. Community Solar
- 2. SD-7 Revisions

## 2019

- 1. VW Settlement
- 2. Power with Purpose
- 3. LED Streetlights
- 4. EV Outreach
- 5. DSM Potentiality
- 6. SD-7 Revisions
- 7. 5 Strategic Initiatives Launched

## 2020

- 1. Power with Purpose
- 2. Southwest Sarpy Transmission
- 3. State of the utility
- 4. Powering the Future 2050
- 5. Pathways to Decarbonization
- 6. BNSF Arbor Line
- 7. Green Power

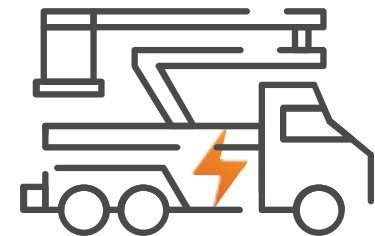
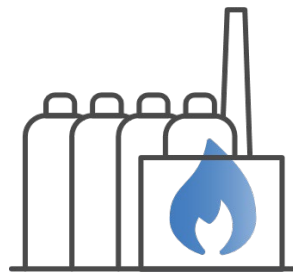
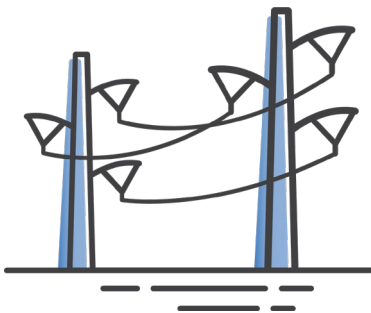




# 2021 outreach included many large-scale initiatives

Initiatives, projects & continued areas of focus since our last report

- Power with Purpose
- Southwest Sarpy Transmission Project
- Powering the Future to 2050
- Pathways to Decarbonization – Energy Portfolio, Community and Customer Pathways
- Customer Engagement for the Future
- BRIGHT Battery Storage Project
- Integrated Resource Plan
- CEO Transition
- Green Power
- Emergency Response – Polar Vortex, Windstorm

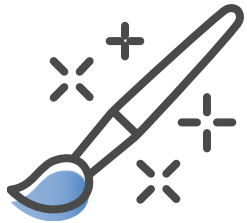


# The Art and Science of Stakeholder Outreach

## SD-13 requires we use both intuition and measurement

**Art** is intuitive, imprecise and subjective

- **Trusted relationships, creative approaches**
- SD13 provides stakeholders a voice in the process
- No two stakeholders are alike, and outreach is not one-size-fits-all
- OPPD flexes to meet stakeholders where they are
- OPPD has built trusted relationships and cultivated a culture of stakeholder collaboration



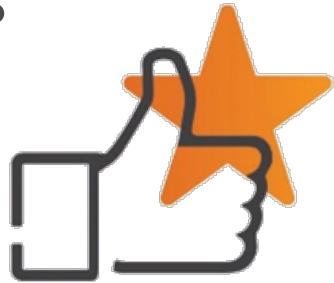
**Science** is researched, measured and objective

- **Measurement, continual improvement, new tools**
- Proven approaches – like IAP2 – help us align with industry standards
- Benchmarking and research are used to identify gaps and best practices
- Measuring results helps us make real-time adjustments to broaden our reach

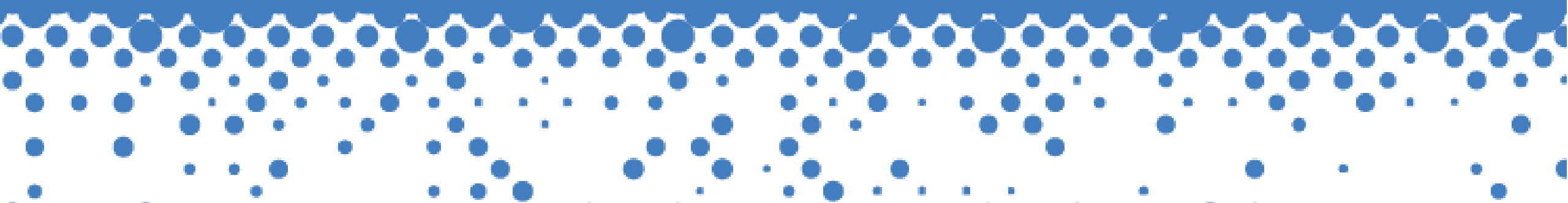


# As a result, we measure success in many ways.

- Success is supporting OPPD's Strategic Directives, Strategic Initiatives and other business objectives to deliver an outcome where stakeholder engagement is critical
- Success may look different from one individual or group to the next, and even from one project to the next
- Success doesn't always mean agreement or consent
  - ✓ Were stakeholders engaged in meaningful ways?
  - ✓ Were they informed using multiple methods?
  - ✓ Even if stakeholder didn't agree with the decision, were they satisfied with the process?
  - ✓ Do they understand how and why decisions were made?
  - ✓ Did we listen and make accommodations where we could throughout the process?



Integrated, Clear,  
Transparent  
Engagement



# A quick review of our approach: the International Association of Public Participation (IAP2) Spectrum

- Consistent and transparent
- Important to recognize these are levels, not steps
- Alignment with other public participation practitioners
- OPPD part of local group that spearheaded Nebraska IAP2 Chapter

	 <b>INFORM</b>	 <b>CONSULT</b>	 <b>INVOLVE</b>	 <b>COLLABORATE</b>	 <b>EMPOWER</b>
<b>PUBLIC PARTICIPATION GOAL</b>	To provide the public with balanced and objective information to assist them in understanding the problem, alternatives, opportunities and/or solutions.	To obtain public feedback on analysis, alternatives and/or decisions.	To work directly with the public throughout the process to ensure that public concerns and aspirations are consistently understood and considered.	To partner with the public in each aspect of the decision including the development of alternatives and the identification of the preferred solution.	To place final decision making in the hands of the public.
<b>PROMISE TO THE PUBLIC</b>	We will keep you informed.	We will keep you informed, listen to and acknowledge concerns and aspirations, and provide feedback on how public input influenced the decision.	We will work with you to ensure that your concerns and aspirations are directly reflected in the alternatives developed and provide feedback on how public input influenced the decision.	We will look to you for advice and innovation in formulating solutions and incorporate your advice and recommendations into the decisions to the maximum extent possible.	We will implement what you decide.

# IAP2 helps us define objectives for large projects, but outreach is also an ongoing relationship – connecting with the communities we serve

## Objective:

- To inform and consult from 1:1 meetings to large gatherings
- Build relationships, build trust and make connections
- Manage and foster relationships through calls, meetings and handshakes
- Communicate and gather feedback

## Outcome:

- Partnerships with community leaders and elected officials
- Helps define customized, customer outreach efforts
- Fosters connection and advocacy in the communities we serve



# Growing meaningful ways for customer-owners to participate and provide feedback.

Objective: Be the first and best source of information

# OPPDCommunityConnect.com launched in July 2020 and continues to grow.

## Objective:

To lead the way and be the first and best source of information; increase opportunities for engagement and improve reporting

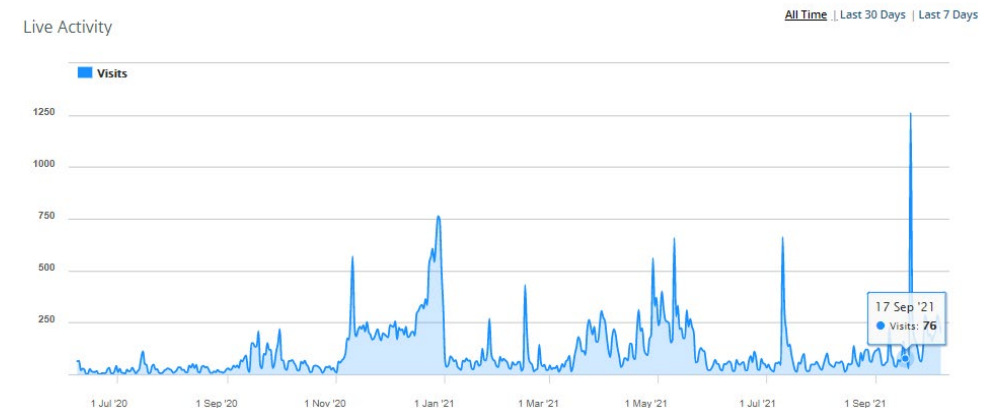
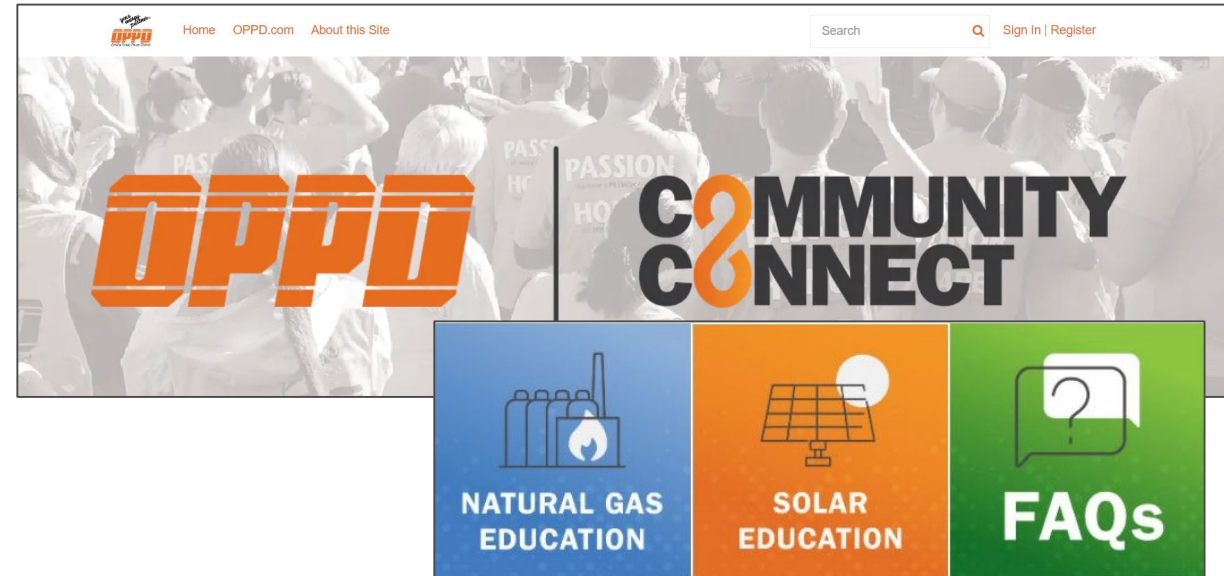
## Statistics:

### Projects

- Power with Purpose, Pathways to Decarbonization, transmission projects, feedback on SDs and CEO transition, Powering the Future to 2050, BRIGHT project, etc.

### Visitors

- 47,000 between July 2020 thru August 2021
- 468 have registered to engage on the site





# Stakeholder Facing Outreach & Communications

*Provide opportunities for stakeholders to engage "where they are"*



# Our digital presence is maturing, which supports outreach efforts.



Websites



Sentiment



Social Media

## ***THE WIRE***

Jan. 1 through Sept. 25  
(compared to same period in 2020)

**Users:** 114,453 (up 157%)  
**Page views:** 186,077 (up 47%)  
**Unique page views:** 170,128 (up 119%)  
**New visitors:** 76% (up 13%)

## **Storm & Outage Center**

Jan. 1 through Sept. 25  
(compared to same period in 2020)

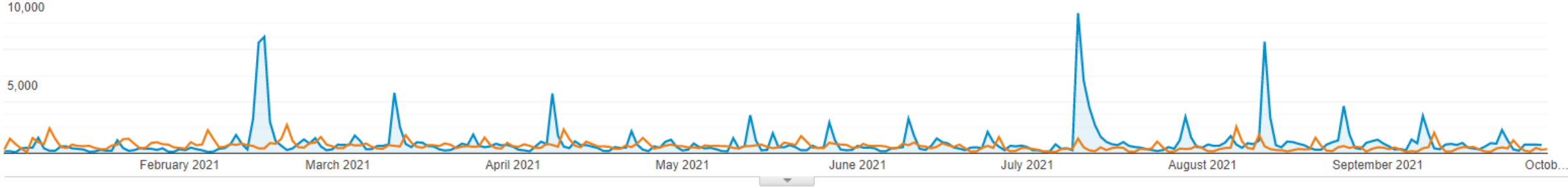
**Users:** 402,727 (up 225%)  
**Page views:** 2,383,270 (up 299%)  
**Unique page views:** 1,155,132 (up 339%)  
**New visitors:** 73.6% (down 5%)

\* **Data note:** The extreme weather events of 2021 (Feb. and July) greatly impacted these numbers

# The Wire continues to grow its reach and viewership...

Jan 1, 2021 - Sep 30, 2021: ● Pageviews

Jan 1, 2020 - Sep 30, 2020: ● Pageviews



Sessions

**135.57%**

150,484 vs 63,881



Users

**157.31%**

115,890 vs 45,039



Pageviews

**47.66%**

188,479 vs 127,646



# ...As does our Storm & Outage Center

Jan 1, 2021 - Sep 30, 2021: ● Users

Jan 1, 2020 - Sep 30, 2020: ● Users



Sessions

**343.15%**

993,748 vs 224,248



Users

**220.03%**

421,476 vs 131,699



Pageviews

**294.57%**

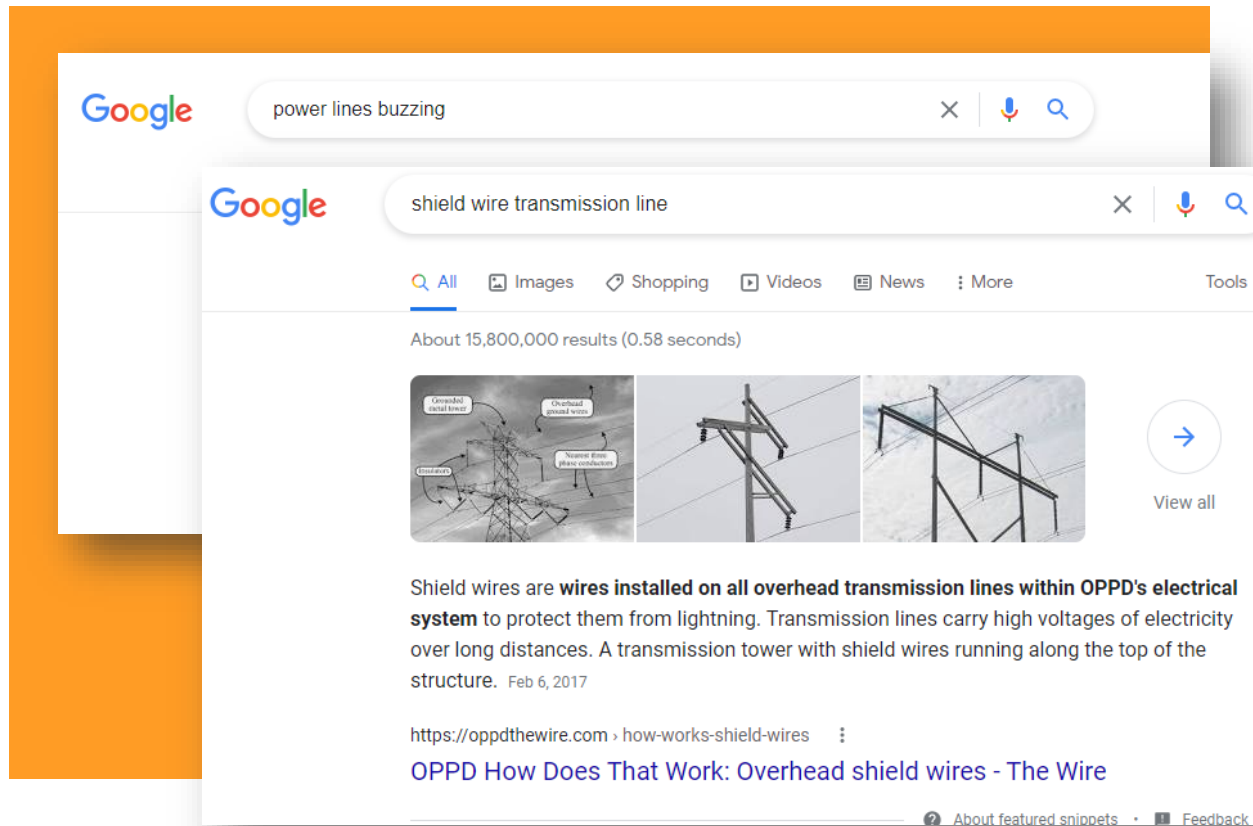
2,387,551 vs 605,105



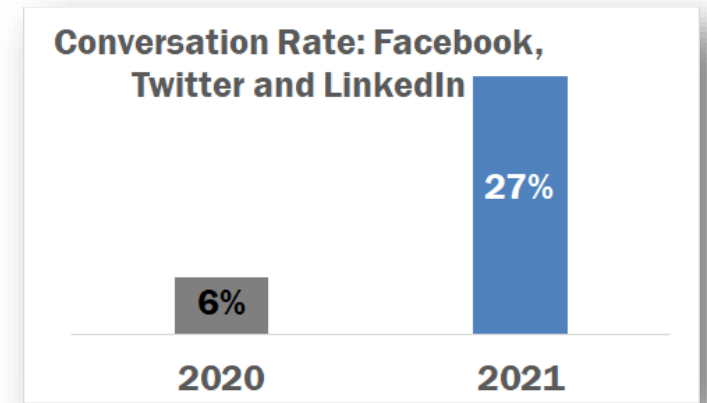
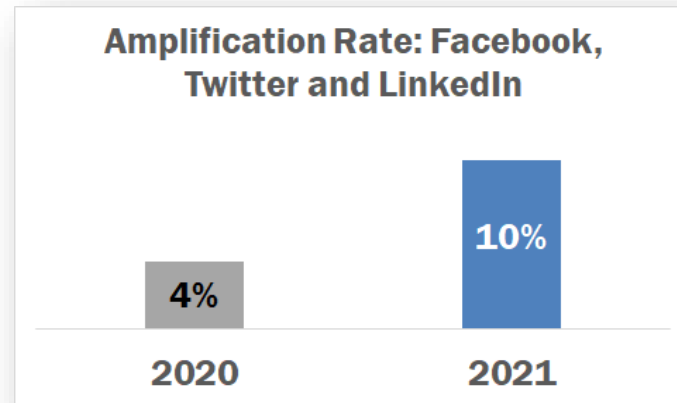
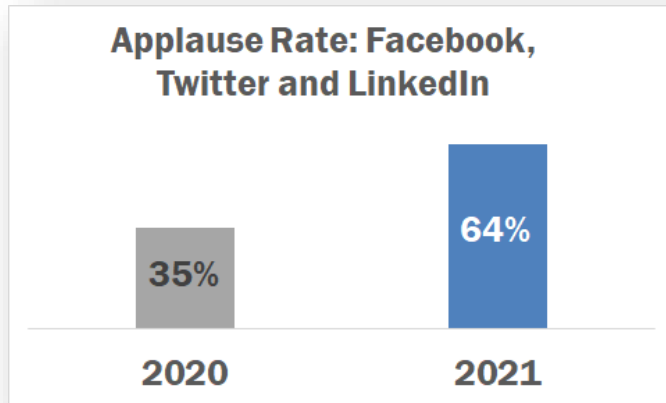
# We're the first and best source of information on Google for key educational topics.

The Wire consistently ranks in Google Top 5 search results for topics like:

- "Shield wire transmission line" and "overhead shield wire"
- "How do smart power strips work"
- "Ice on power lines" and other ice and power lines-related queries
- "How to use a hot stick"
- "Power lines buzzing"/"why do power lines buzz"
- "Difference between power lines"



# For social media, we measure not just sentiment, but overall engagement across multiple channels, and we're improving.



Applause rate represents the ratio of positive reactions to followers



Amplification rate represents the ratio of shares and retweets to followers



Conversation rate represents the ratio of comments and mentions to followers

# Customers are highly engaged in our industry leading Power Panel and are offering invaluable insights

Since 2014, we've maintained a nearly 5,000 customer membership on our Power Panel. We continually recruit and aim for representation across geography and a number of demographics.

Our studies grow in sophistication. In 2020 and 2021 we've used the panel for:

- Block Rates Live Chat Sessions
- Stakeholder Outreach Preference Study
- OPPD Bill and Website Evaluations
- OPPD State of the Utility Comm Study
- Power With Purpose – Land Resource Perceptions Study
- Decarbonization Customer Pathways Work
- CEO finalist virtual meet-and-greet communication and transition survey
- OPPD Reliability Improvements Website Evaluation
- Various Product Development & Marketing studies

The screenshot shows the OPPD Power Panel website. At the top, the text "OPPD POWER PANEL" is displayed in orange and black, with a circuit-like graphic to the right. The OPPD logo, featuring the text "Your energy partner" above "OPPD" and "Omaha Public Power District" below, is in the top right corner. The main content area is divided into three sections: a large image of wind turbines on a grassy hill, a "WELCOME" message, and a "MEMBER SIGN IN" form. The "WELCOME" message reads: "While you may not think about OPPD each time you flip on the switch, we're thinking about you and want to know what's on your mind. The OPPD Power Panel is a place for you to share your thoughts on energy-related issues, so we can better serve you. Thank you for participating!". The "MEMBER SIGN IN" form includes input fields for "Email" and "Password", a "Remember me" checkbox, a "SIGN IN" button, and a "Forgot password?" link. At the bottom, a dark footer contains links for "PRIVACY POLICY", "TERMS OF USE", and "TECHNICAL SUPPORT", along with the text "Powered by VISIONCRITICAL" and the OPPD logo.

Share Context with  
Customer-Owners for Key  
Decisions.

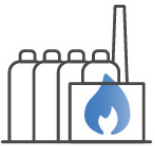




# Stakeholder Outreach – Long term examples of multi-year initiatives with many projects within each

## 2+ Years of Engagement

### Power with Purpose



Two natural gas sites



Gas pipeline outreach



Multiple solar sites



Routing and siting public involvement for all transmission and distribution efforts

### Pathways to Decarbonization



Energy portfolio pathway



Customer pathway



Community pathway

# Stakeholder Outreach – Less than 1 year examples

## Other Extended Engagement

- **Board of Directors Support**
  - CEO transition
  - SD7 feedback
- **Strategic Initiatives**
  - Powering the Future 2050
  - Customer Engagement for the Future
- **Other**
  - Coal Combustion Residual (CCR)  
Selection of Remedy public meetings
  - Product support (EV outreach)



# Real Time Update – Sarpy County Transmission Project

First in-person and virtual public hearing on 10/5/2021

## Project Timeline & Engagement

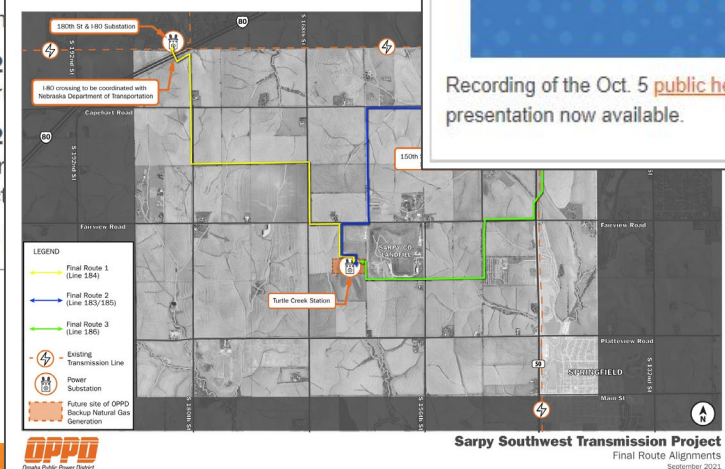
### What We've Done

- ✓ **November 2020 – February 2021**  
Phase 1: Identify Study Area and Environmental Constraints
- ✓ **January 26, 2021**  
Phase 1: Online Public Meeting
- ✓ **February 2021 – March 2021**  
Phase 2: Route Segment Analysis
- ✓ **March 30, 2021**  
Phase 2: Online Public Meeting
- ✓ **April 2021 – May 2021**  
Phase 3: Route Alternative Analysis
- ✓ **May 2021**  
Final Route Announcement

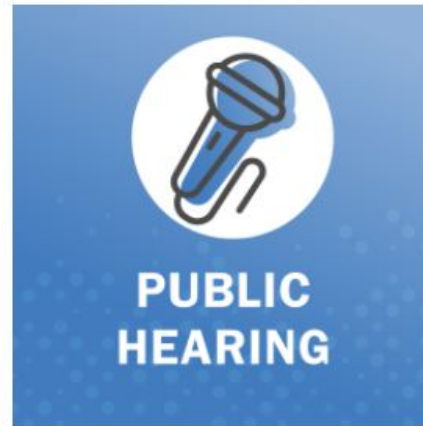
### Where We're Going\*

- **May 2021 – January 2022**  
Engineering/Design/Right-of-Way Activities
- **October 5, 2021**  
Public Hearing
- **October 2021 – October 2022**  
Procurement
- **November 2021 – March 2022**  
Easement
- **May 2022**  
Construction
- **May 2023**  
Project Completion

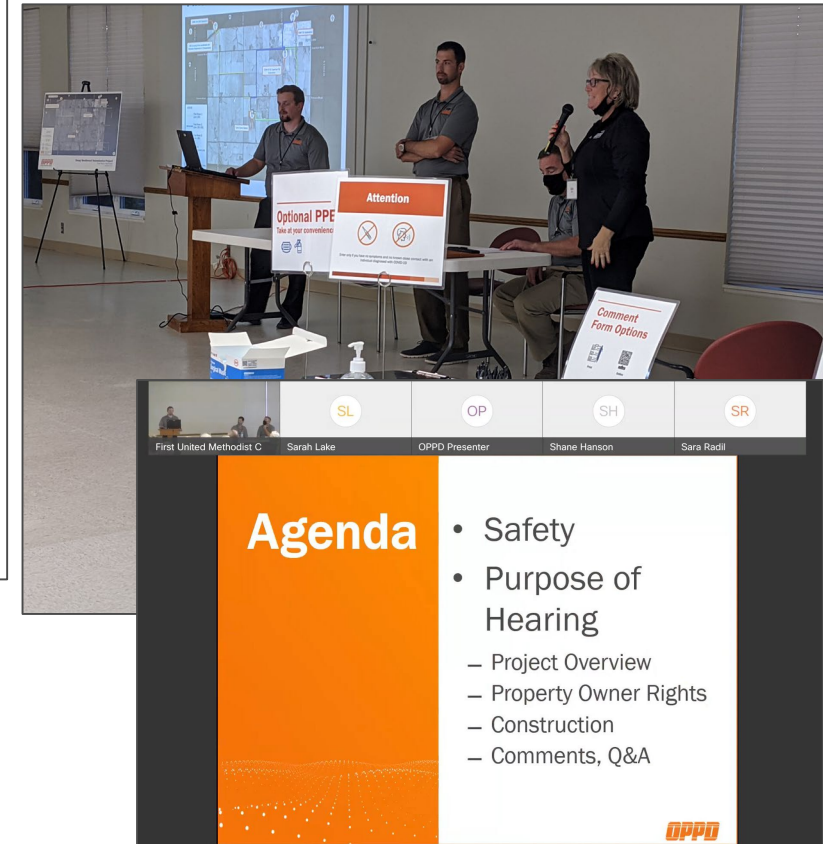
\*All dates are subject to change and may differ



### Public Hearing



Recording of the Oct. 5 public hearing and presentation now available.



# Platteview Solar - Engagement

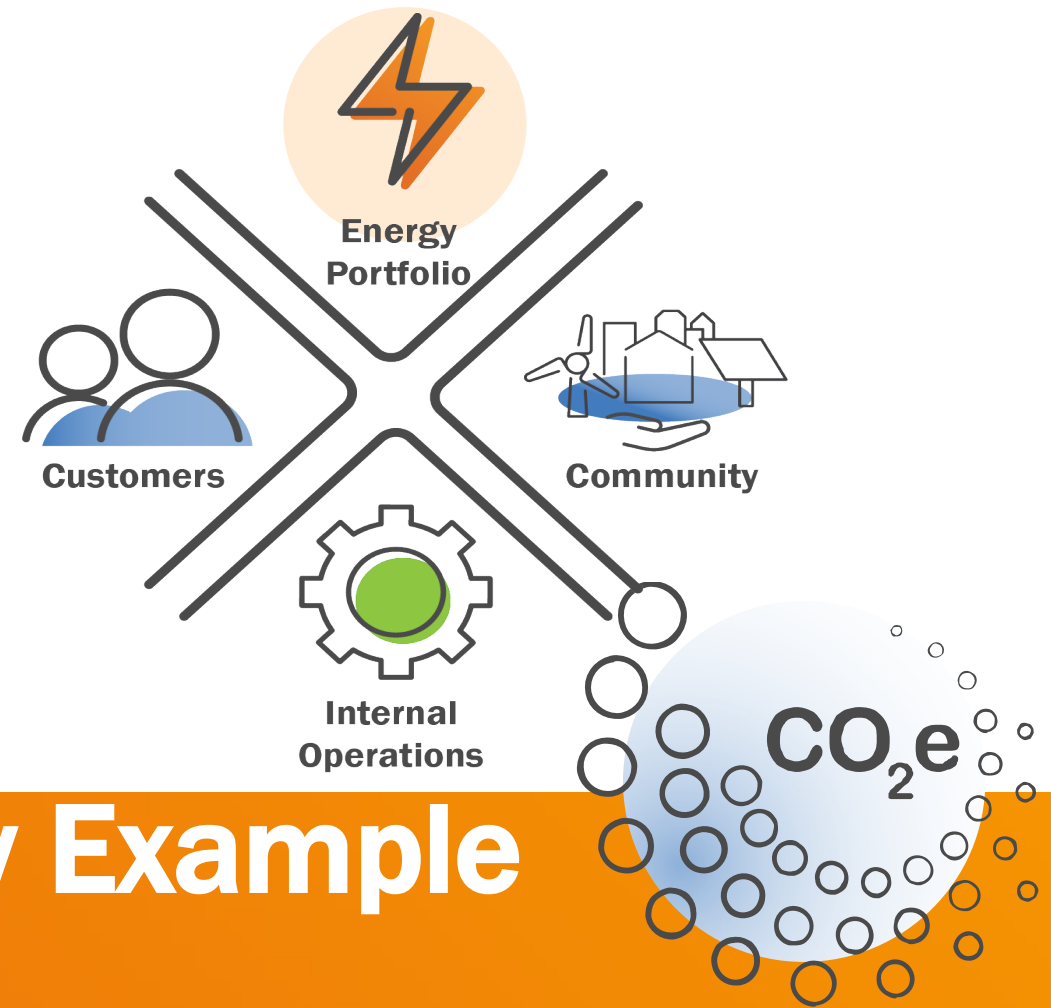
**Objective:** Support the delivery and approval of the Platteview Solar Project

**Outcome:** Project has been approved

## Stakeholder Engagement

- Partnership with Community Energy
  - Developed FAQs and Project Website
  - Co-hosted in-person open house
  - Created project impact analysis
- Dozens of meetings and 1:1s
- Advocated for the project at numerous public meetings
- *Commitment to continued engagement with Saunders County Officials and residents*





# Pathways to Decarbonization

## Deep Dive Case Study Example



# Pathways to Decarbonization – Discovery Sessions

*December 2020 – January 2021*

## Objective:

- Listen to stakeholders about how they want to be involved

## Outcome:

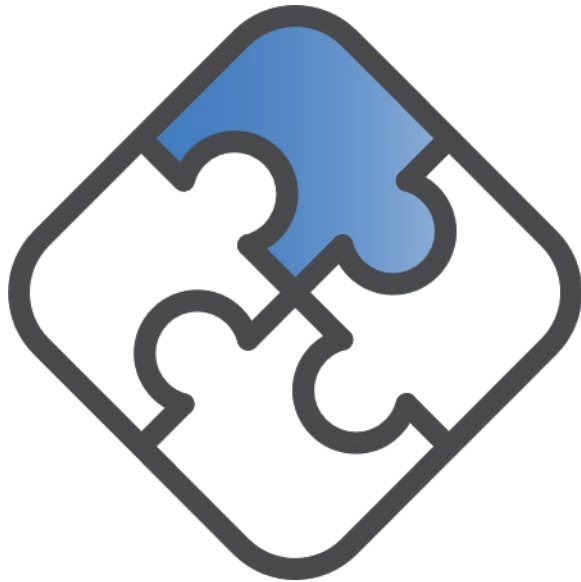
- Helped OPPD understand what success looks like to them
- Used input to shape the outreach plan, resulting in greater satisfaction with the process
- Created advocates to help carry the message to a broader audience

## Outreach Level (IAP2):

- Consult



# Pathways to Decarbonization – Discovery Sessions



OPPD Engaged representatives from environmental advocacy organizations to ask open-ended questions:

- *What interests you about this strategic initiative?*
- *What does success look like to you?*
- *Where do you see opportunities to provide feedback?*
- *How would you like to be engaged?*
- *Would you be willing to share information with others in your organization?*

This important information informed our outreach plan.

# Discovery Session Takeaways

- Stakeholders sometimes feel unaware – Need upfront communication, time to digest information and opportunities to provide input before final decisions are made.
- Stakeholders recognize the need for layered approach – understanding that all stakeholders are not engaged at same level, including their own membership.
- OPPD can help stakeholders translate technical information and provide shareable information (articles, social media content, infographic).
- Provide transparency about how feedback was used or not used, clarify assumptions made behind decisions, and provide timelines relative to decision points (close loops).
- Be clear on what we're seeking from stakeholders – type of feedback that is helpful.
- Use new, non-traditional communication tools (text messaging, board member social media communications, NextDoor app).
- OPPD doing better than most utilities on engagement and accessibility of information.
- Stakeholders appreciated the opportunity to be engaged early in the process.





# Shareable Content

We realize not everyone can attend a two-hour technical workshop, but they want the information

## Discovery Session Takeaway:

- Key stakeholders recognized need for layered approach, as customers are not engaged at same level.
- Stakeholders want help translating technical information to their constituencies.

## Outcome:

- **Executive Summaries:**  
Following every Energy Portfolio workshop, Executive Summaries were posted on OPPDCommunityConnect and emailed to key stakeholders for distribution within stakeholder organizations
- **Video:**  
Created 22-minute video to highlight 8 hours of workshops (highlight reel)

**PATHWAYS TO DECARBONIZATION: Energy Portfolio Workshop #2**

OPPD, with support of Energy+ Environmental Economics (E3), is conducting a series of workshops to engage stakeholders in the Energy Portfolio decarbonization planning process. **Workshop #2** provided insight to the **multi-sectoral net-zero carbon modeling results** across all energy uses in OPPD's service territory. A recording of the workshop is available [online](#).

### Multi-Sector Modeling

**1 Low-Carbon Electricity is Vital to Community Decarbonization**

OPPD set the stage by emphasizing the fact that low-carbon electricity is critical to achieving community-scale decarbonization. To achieve deep carbon reduction, electrification of building and transportation systems must occur in parallel with a transition to low-carbon electricity. In combination, these strategies enable widescale transition away from fossil fuels.

**Workshops**

- ✓ **Pathways Planning 101**  
April 7, 2021  
4-6 p.m.
- ✓ **Multi-Sector Modeling**  
April 28, 2021  
4-6 p.m.
- **Key Assumptions & Scenarios**  
May 12, 2021  
4-6 p.m.
- **Modeling Approach**  
May 26, 2021  
4-6 p.m.
- **Modeling Activities**  
Q2/Q3 2021
- **Initial Results**  
Q3/Q4 2021
- **Final Results**  
December 2021

**CO<sub>2</sub> NEUTRAL**

[www.OPPD.com](http://www.OPPD.com)  
This site provides and videos

**Energy Portfolio Project Summary Video**

OPPD Pathways to Decar...

**Pathways to Decarbonization**  
ENERGY PORTFOLIO PROJECT

OPPD

# Stakeholder Engagement and Trust Leads to Advocacy

Stakeholders requested sharable content, we responded to be the first and best source

## Excerpt from Citizen's Climate Lobby Email:

*OPPD is working hard on decarbonization.*

*Their “community connects” website offers a way we can give them our suggestions about what will work in Omaha.*

*They need to hear from us and you don't have to be an energy expert. Go here:  
[OPPDCommunityConnect.com](http://OPPDCommunityConnect.com)*

# Transparency

## Discovery Session Takeaway:

Stakeholders want more transparency around how feedback was used or not used, clarity on assumptions made behind the decisions, and timelines relative to decision points (close loops)

## Outcome:

- *Interim Update:*  
Between workshops 4 and 5, an interim update session was added!

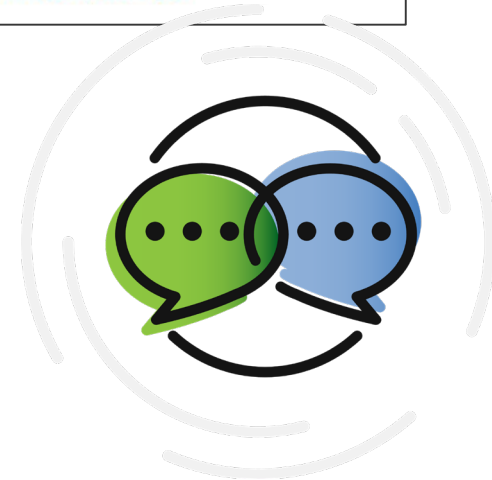
## Objectives

Share an update on stakeholder contributions, modeling progress, and next steps



## Agenda

- Strategic Initiative Overview
- Context of Workshop
- Integrated Resource Plan Connection
- Impacts of Stakeholder Engagement
- Interim Modeling Update
  - Project progress update
  - Reliability results
  - **Open Comment Period**
  - Resiliency case studies
  - **Open Comment Period**
  - Portfolio optimization
- Next Steps
- **Open Comment Period**



# Energy Portfolio Workshops

April – December 2021

## Objective:

- Provide a deeper dive on the decarbonization planning process and how it will support OPPD's Integrated Resource Plan (IRP)
- Seek feedback along the way and explain how feedback was or wasn't used
  - Q&A or raise hand feature in WebEx
  - Poll Everywhere
  - OPPDCommunityConnect

## Outcome:

Higher satisfaction with process

## Outreach Levels (IAP2):

- Varied from Inform to Consult



# Decarbonization – Energy Portfolio Workshops

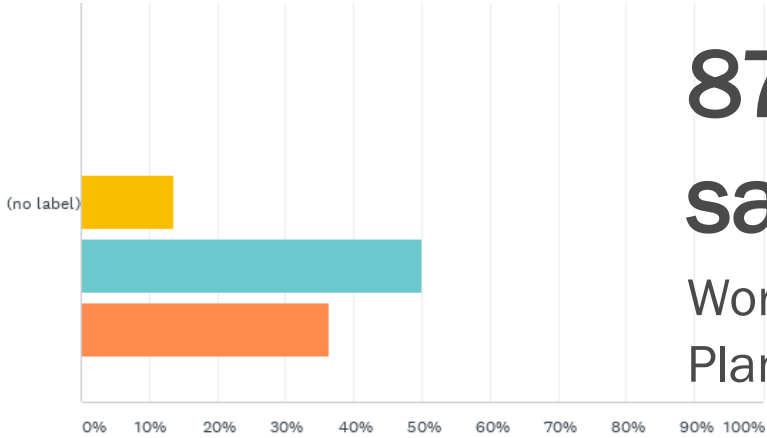
*(and speaking engagements)*

- ✓ April 7 Workshop 1: Pathways Planning 101
- ✓ April 28 Workshop 2: Multi-Sectoral Modeling
- ✓ May 12 Workshop 3: Developing Key Assumptions & Scenarios
- ✓ May 26 Workshop 4: Developing Modeling Approach
- Aug. 4 Interim Modeling Update
- Q4 2021 2 more workshops coming...**
- Oct. 27 Initial Final Results and
- Dec. 9 Final Results

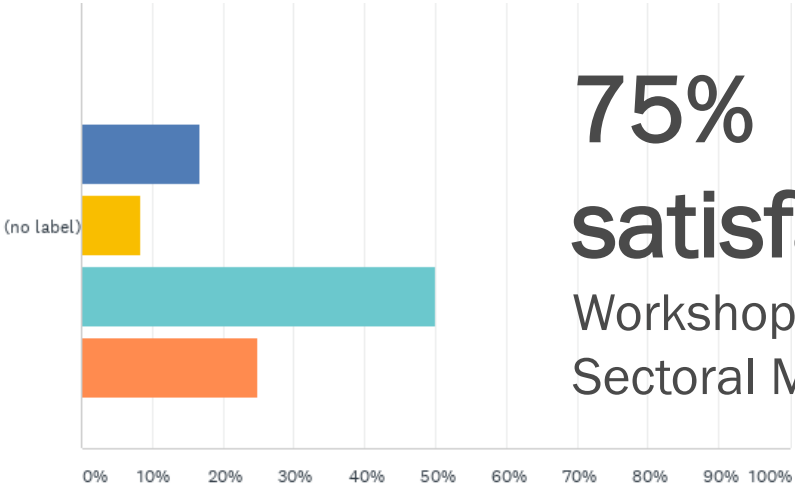
## Speakers Bureau Engagement

- MAPA – Natural Resources Committee
- Green Bellevue
- Sierra Club

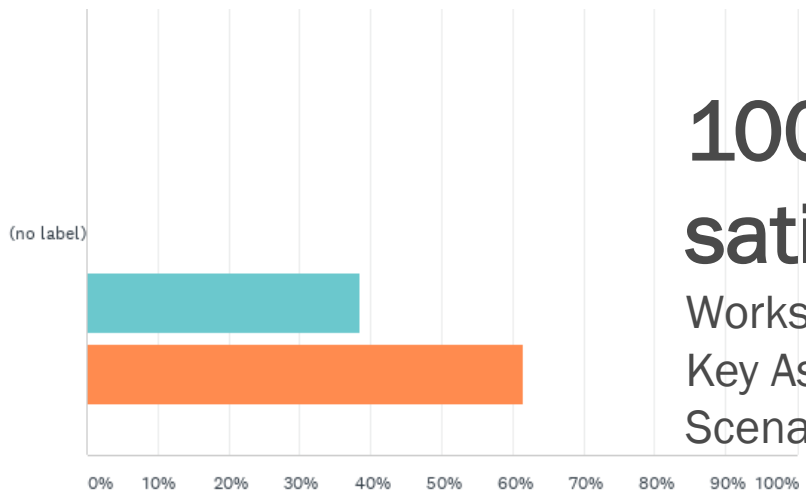
# Decarbonization Energy Portfolio Workshop Feedback



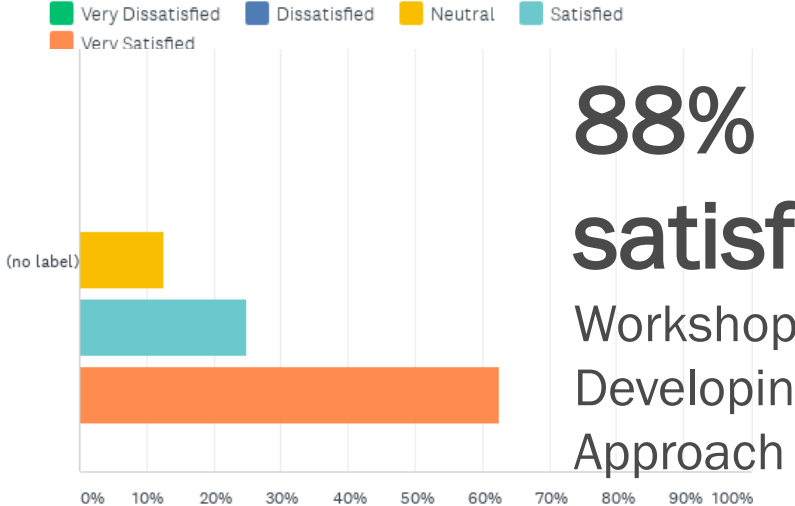
**87%**  
**satisfaction**  
 Workshop #1: Pathway Planning 101



**75%**  
**satisfaction**  
 Workshop #2: Multi-Sectoral Modeling



**100%**  
**satisfaction**  
 Workshop #3: Developing Key Assumptions & Scenarios

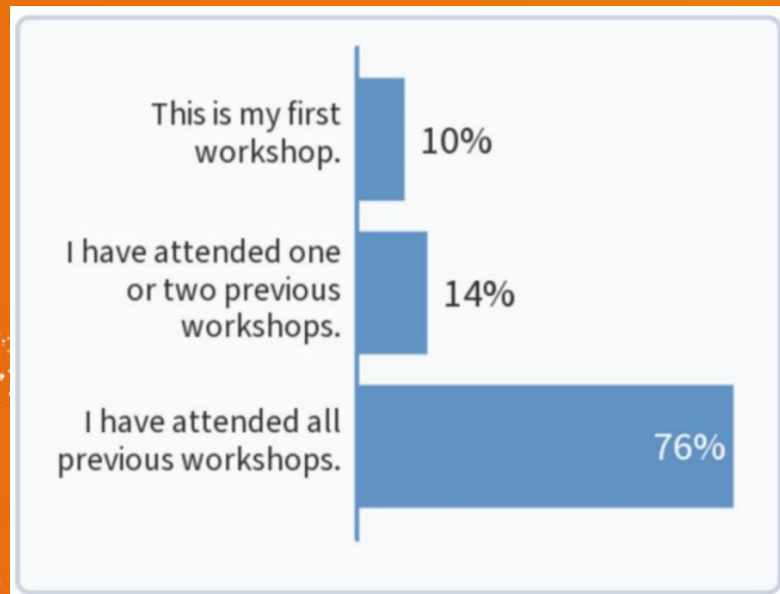


**88%**  
**satisfaction**  
 Workshop #4: Developing Modeling Approach

# Workshop Attendees

Approximately 100 people have attended one or more workshop

Many attended multiple workshops within the series



## Examples of types of attendees

- Customers
- Advocacy Organizations
- Educators
- Utilities
- Students
- Consulting & Engineering Firms
- Suppliers
- Elected Officials
- Individuals interested outside of our service area



Recorded workshop material have more than 400 views

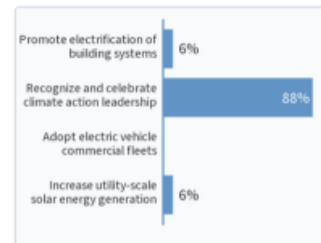
# Stakeholder Feedback

“Thank you for this (update emails) and all the information and the workshops and, well, all of it.”

“I probably don't say it enough but you guys are doing a great job in making the process truly public and valuing the input of your customer-owners and other stakeholders.”

## Implemented tools for real time feedback

Which of the following is considered an Enabler, meaning the strategy facilitates change but may not result in measurable emission reductions in itself?



Response options	Count	Percentage
Promote electrification of building systems	1	6%
<b>Recognize and celebrate climate action leadership</b>	<b>15</b>	<b>88%</b>
Adopt electric vehicle commercial fleets	0	0%
Increase utility-scale solar energy generation	1	6%

53%

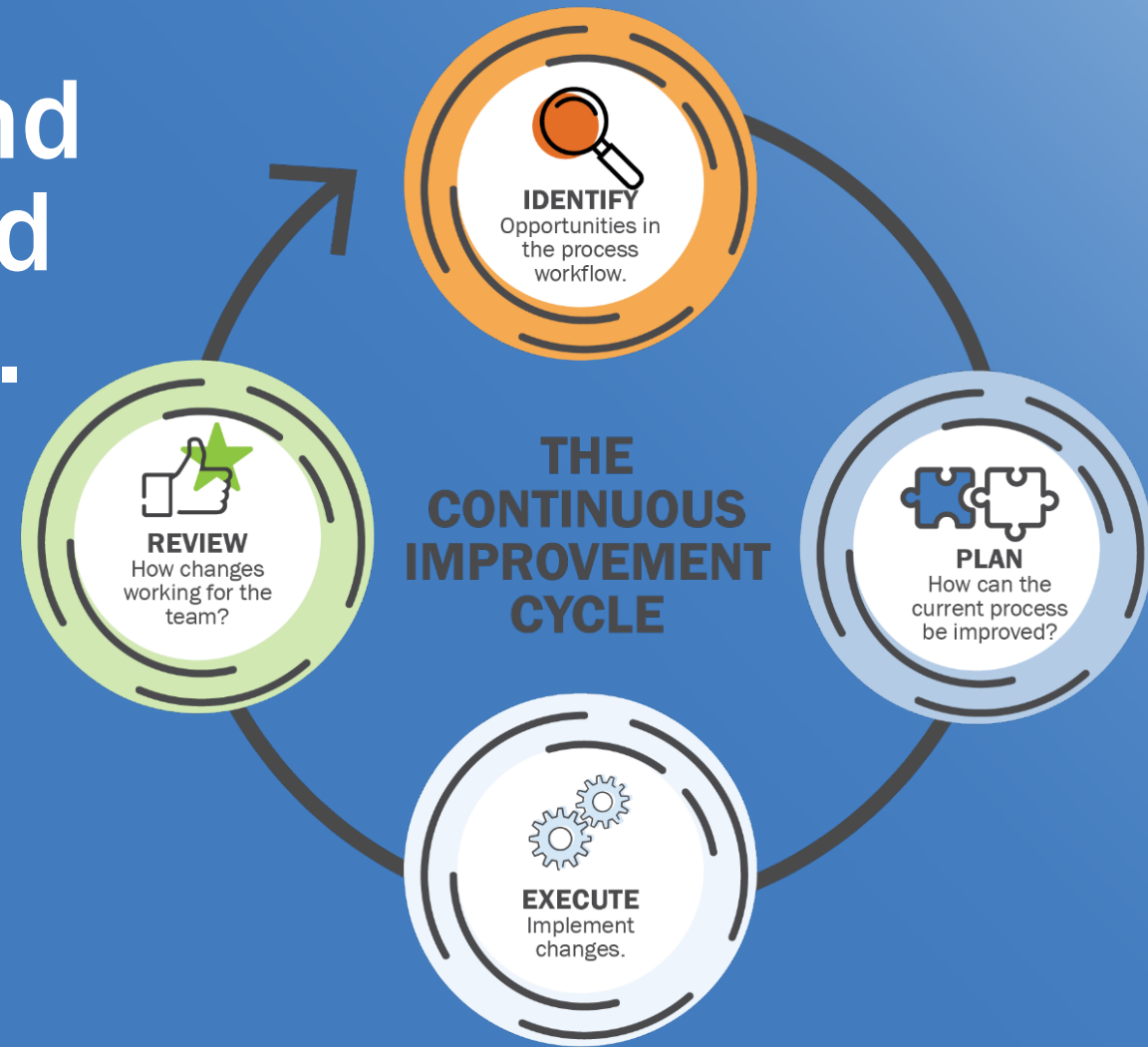
Engagement

17

Responses



# Continuously Evaluate and Improve its Outreach and Engagement Processes.



# We Listen, We Learn, We Look to Improve



- Post-event surveys
- Poll everywhere
- Debriefs
- Training and development
- Networking and relationships
- Research and benchmarking
  - Customer engagement study
  - Utility engagement benchmarking study

A screenshot of a Zoom meeting interface. At the top, there are five video thumbnails for participants: Laurie Zagurski, Jamie Wagner, Jeremy Bowers, Colton Kennedy, and Zachary Ming. Below the thumbnails is a section titled "Questions and Answers" with the text "Thank you for your feedback today. Now it's time for some Q&amp;A." There are two sub-sections: "Q&amp;A function" and "Hand Raise". The "Q&amp;A function" section includes instructions on how to use the Q&amp;A feature. The "Hand Raise" section includes instructions on how to raise and lower one's hand. To the right of the text are two screenshots of the Zoom interface: the top one shows the "Q&amp;A" button in the bottom right corner, and the bottom one shows the "Hand Raise" button in the bottom right corner. At the bottom of the screenshot, there is a video player control bar with a play button, a volume icon, a progress bar showing 1:34:09 / 1:46:58, and other standard video player controls. A small text at the bottom right of the screenshot reads "Meeting video will be posted on OPPDCommunityConnect.com".

# Internal OPPD Audit



- Corporate Auditing conducted an audit
- Determined if adequate controls and processes were in place for stakeholder outreach and engagement programs
- Areas assessed included stakeholder outreach, community outreach and grant funding
- A number of tools and processes put in place to ensure consistency and alignment across OPPD
  - Stakeholder Outreach template for gathering pre-event details from project managers
  - OPPDCommunityConnect reports
  - Surveys, policies, guidelines in place

# Customer Outreach Study/Preferences

- **Collected customer opinions across the service territory**
  - 800+ complete surveys via Telephone and online Power Panel
  - Oversampled six counties in phone survey to ensure customer representation
- **Most respondents expressed they want to be informed vs. involved in decision making**
  - Expressed trust in OPPD to be the expert decision-maker
  - Prefer to be informed via direct mail (bill inserts, newsletters)
- **Approximately one-fifth desire to be included throughout the decision-making process**
  - Energy cost and environmental impacts are standout topics



# Stakeholder Engagement Benchmarking Study

## Objective:

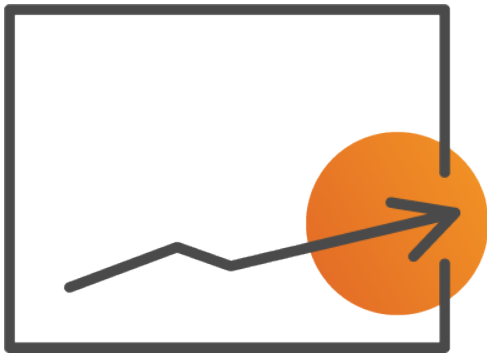
- In-depth interviews and evaluation of how other utilities and organizations employ stakeholder engagement
- Identify gaps and best practices
- Share results with participants

## Participant Interviews:



**Additional research including:** Ameren, TVA, City of Omaha, Des Moines Water Works and Denver Water

# We Look Continuously to Improve



## Benchmarking Takeaways:

- OPPD, in most cases, is leading the way (utilizing IAP2 guidelines)
- Continue to tailor communications and delivery tools based on audience
- Social media must be concise and visual to cut through millions of messages that people are exposed to
- Embrace hybrid approach to public involvement – virtual and in-person
- Involve stakeholders and use as sounding board for establishing rules and expectations
- Consider dedicated team just for IRP and generation-related outreach

# Stakeholder Feedback

*More verbatim survey comments in Appendix*

*“I am incredibly impressed by OPPD's approach to tackling this problem. Being future looking, data driven, and open to all options is the path to success.”*

*“The workshop provided detailed information on OPPD's evaluation process for achieving decarbonization. I appreciate the transparency.”*

*“Great detailed information and exceptional experts.”*

*“This is a complicated process. I have been impressed with the effort OPPD is making to allow for input and provide for transparency.”*

*“There was a lot of information presented, so the pre-read materials were quite helpful.”*

*“Very clear, especially given the volume and scale of the presentation.”*

**PATHWAYS TO DECARBONIZATION:**  
**Energy Portfolio Workshop** #2

OPPD, with support of Energy+Environmental Economics (E3), is conducting a series of workshops to engage stakeholders in the Energy Portfolio decarbonization planning process. **Workshop #2** provided insight to the **multi-sectoral net-zero carbon modeling results** across all energy uses in OPPD's service territory. A recording of the workshop is available [online](#).

### Multi-Sector Modeling

- 1 Low-Carbon Electricity is Vital to Community Decarbonization**  
OPPD set the stage by emphasizing the fact that low-carbon electricity is critical to achieving community-scale decarbonization. To achieve deep carbon reduction, electrification of building and transportation systems must occur in parallel with a transition to low-carbon electricity. In combination, these strategies enable widescale transition away from fossil fuels.
- 2 All Sectors of the Economy Must Undergo Transformation**  
Electrification of building and transportation systems requires fundamental changes in infrastructure that make up the fabric of our communities. For example, achieving community-scale decarbonization will require development of convenient and effective electric vehicle (EV) charging infrastructure and retrofit of existing building stock to improve energy efficiency and electrify heating systems.

**Workshops**

- ✓ **Pathways Planning 101**  
April 7, 2021  
4-6 p.m.
- ✓ **Multi-Sector Modeling**  
April 28, 2021  
4-6 p.m.
- **Key Assumptions & Scenarios**  
May 12, 2021  
4-6 p.m.
- **Modeling Approach**  
May 26, 2021  
4-6 p.m.
- **Modeling Activities**  
Q2/Q3 2021
- **Initial Results**  
Q3/Q4 2021
- **Final Results**  
December 2021

**Learn more at**  
[www.OPPDCommunityConnect.com](http://www.OPPDCommunityConnect.com)  
This site provides project updates, answers to FAQs, and videos of our workshop meetings.

**CO<sub>2</sub> NEUTRAL**  
2050

Your Energy Partner  
**OPPD**  
Omaha Public Power District

# Stakeholder Feedback

*More verbatim survey comments in Appendix*

*“Complicated topic well presented. Outstanding job.”*

*“Being green is only easy if you are not the utility doing it!  
Again nice job!”*

*“Good information throughout. The polar vortex example  
was a good illustration of the challenge that we face.”*

*“Sending out the workshop pre-read materials allowed  
me to become familiar with ELCC ahead of time.”*

*“Having all the slides available on OPPD connect for the  
meeting was fantastic and greatly appreciated.”*

*“Well organized with good information.”*

*“The presentations are impressive with the level of detail  
while still maintaining clarity.”*

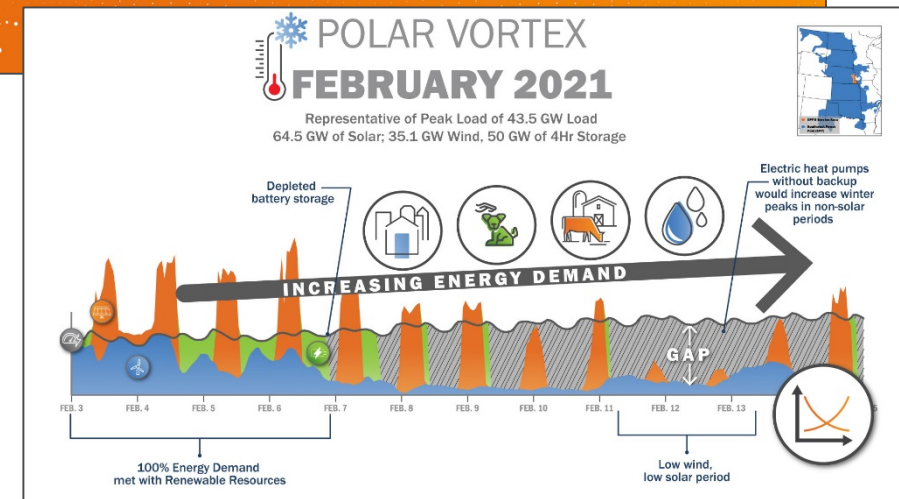
**OPPD**  
Omaha Public Power District

## Pathways to Decarbonization: Energy Portfolio Modeling Approach

Wednesday, May 26, 2021 (4-6 p.m.)

Thank you for joining us for today.  
The workshop will begin soon, and we look forward to the discussion.

Today's content and a recording of today's workshop can be found online at [OPPDCommunityConnect.com](https://oppdcommunityconnect.com).



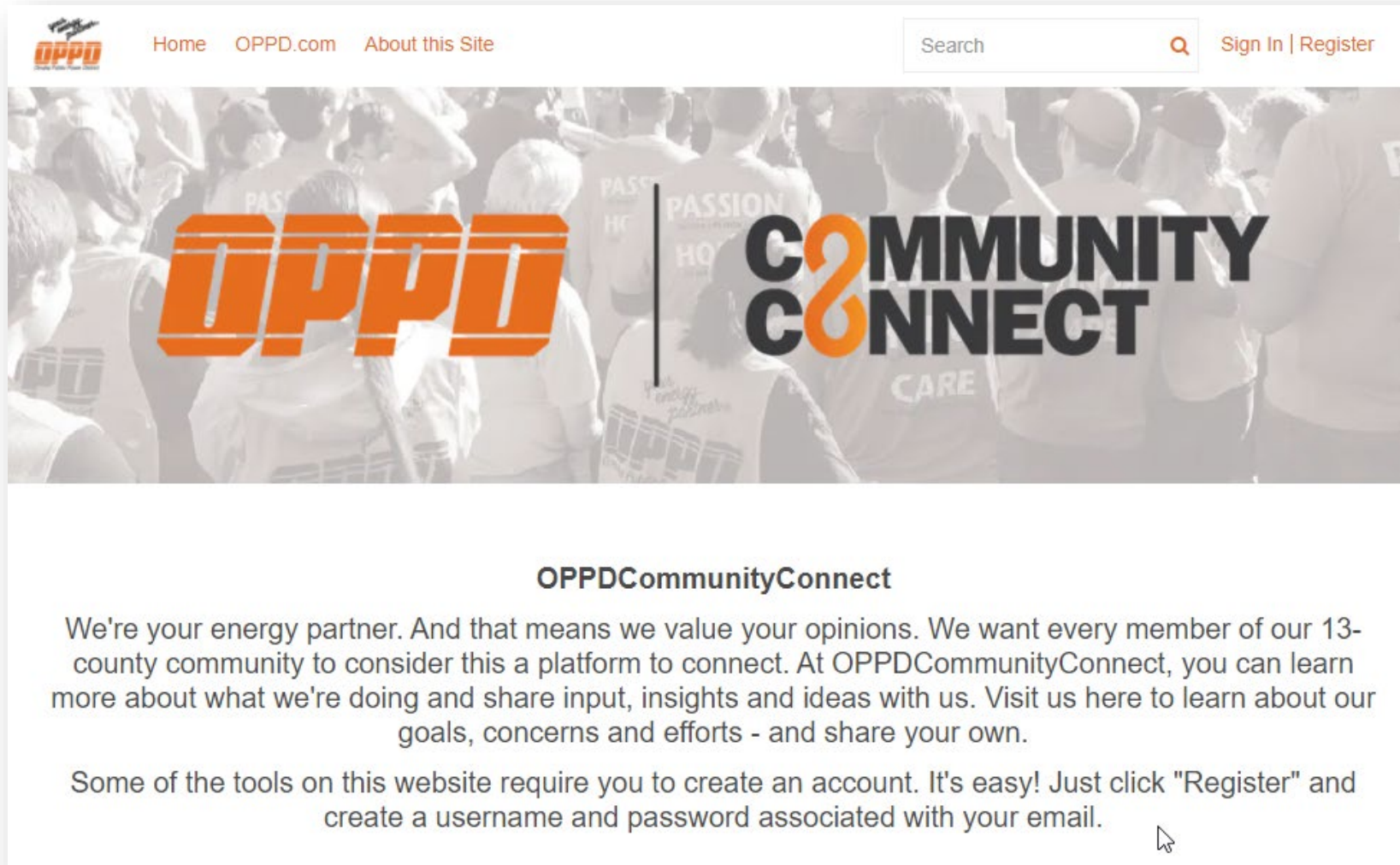


# Key takeaways

- Our internal audits, external benchmarking and overall performance illustrate that we are truly leading the way.
- In an historic and dynamic environment, we've accelerated our outreach maturity and performance.
- Our continuous improvement cycle is working; we're improving, and it shows in our data.
- We've solidified our aspiration to be the first and best source of information. We measure success in many ways, with a focus on stakeholders' satisfaction of our outreach process, no matter the project outcome.



# Stay Engaged at OPPDCommunityConnect.com



The screenshot shows the homepage of the OPPDCommunityConnect website. At the top left is the OPPD logo. To its right are navigation links for 'Home', 'OPPD.com', and 'About this Site'. Further right is a search bar with the text 'Search' and a magnifying glass icon, followed by 'Sign In | Register' links. The main banner features a background image of a crowd of people at a community event. Overlaid on this image are the 'OPPD' logo in orange and the 'COMMUNITY CONNECT' logo in black, with a vertical line separating them. Below the banner, the heading 'OPPDCommunityConnect' is centered. The main text reads: 'We're your energy partner. And that means we value your opinions. We want every member of our 13-county community to consider this a platform to connect. At OPPDCommunityConnect, you can learn more about what we're doing and share input, insights and ideas with us. Visit us here to learn about our goals, concerns and efforts - and share your own.' Below this is a paragraph: 'Some of the tools on this website require you to create an account. It's easy! Just click "Register" and create a username and password associated with your email.'

**OPPD** | **COMMUNITY CONNECT**

### OPPDCommunityConnect

We're your energy partner. And that means we value your opinions. We want every member of our 13-county community to consider this a platform to connect. At OPPDCommunityConnect, you can learn more about what we're doing and share input, insights and ideas with us. Visit us here to learn about our goals, concerns and efforts - and share your own.

Some of the tools on this website require you to create an account. It's easy! Just click "Register" and create a username and password associated with your email.

# Recommendation

The Public Information Committee has reviewed and accepted this Monitoring Report for SD-13 and recommends that the Board find OPPD to be sufficiently in compliance with Board Policy SD-13.



Mollhoff/Olson

**DRAFT**  
**RESOLUTION NO. 64xx**

**WHEREAS**, the Board of Directors has determined it is in the best interest of the District, its employees, and its customer-owners to establish written policies that describe and document OPPD's corporate governance principles and procedures; and

**WHEREAS**, each policy was evaluated and assigned to the appropriate Board Committee for oversight of the monitoring process; and

**WHEREAS**, the Board's Public Information Committee (the "Committee") is responsible for evaluating Board Policy SD-13: Stakeholder Outreach and Engagement on an annual basis. The Committee has reviewed the 2021 SD-13: Stakeholder Outreach and Engagement Monitoring Report and finds OPPD to be sufficiently in compliance with the policy as stated.

**NOW, THEREFORE, BE IT RESOLVED** that the Board of Directors of Omaha Public Power District hereby accepts the 2021 SD-13: Stakeholder Outreach and Engagement Monitoring Report, in the form as set forth on Exhibit A attached hereto and made a part hereof, and finds OPPD to be sufficiently in compliance with the policy as stated.



# DRAFT Agenda

**OPPDP BOARD OF DIRECTORS  
REGULAR BOARD MEETING  
Thursday, October 21, 2021 at 5:00 P.M.**

*Attend in person at Omaha Douglas Civic Center, 1819 Farnam Street,  
2<sup>nd</sup> Floor – Legislative Chamber, Omaha, NE 68183*

*Public may attend remotely by going to [www.oppd.com/BoardAgenda](http://www.oppd.com/BoardAgenda) to access the Webex meeting link and view instructions.*

### **Preliminary Items**

1. Chair Opening Statement
2. Safety Briefing
3. Guidelines for Participation
4. Roll Call
5. Announcement regarding public notice of meeting

### **Board Consent Action Items**

6. Approval of the August 2021 Comprehensive Financial and Operating Report, September 2021 Meeting Minutes, and the October 21, 2021 Agenda
7. SD-12: Information Management and Security Monitoring Report – Resolution No. 64xx
8. North Omaha Station Unit 4 and 5 Burner Replacement – Engineer's Certificate to Negotiate – Resolution No. 64xx
9. Jones Street Station Exhaust Stack Replacements – Engineer's Certification – Resolution No. 64xx
10. RFP 5911 – Steel Structures – Resolution No. 64xx
11. SD-7: Environmental Stewardship Monitoring Report – Resolution No. 64xx
12. SD-13: Stakeholder Outreach and Engagement Monitoring Report – Resolution No. 64xx

### **Board Discussion Action Items**

13. CFO Appointment and Compensation Approval – Resolution No. 64xx
14. [to be determined]
15. Resolution of Appreciation for M. J. Fisher, Vice President – Energy Production & Nuclear Decommissioning – Resolution No. 64xx
16. Resolution of Appreciation for M. L. Sedky, Vice President – Human Capital – Resolution No. 64xx

### **Other Items**

17. President's Report (30 mins)
18. Presidential Award for Jené Reese
19. Opportunity for comment on other items of District business
20. Adjournment

Please use the link below to find all committee and board agendas, materials and schedules. Board governance policies and contact information for the board and senior management team also can be found at [www.oppd.com/BoardMeetings](http://www.oppd.com/BoardMeetings).



# Board Work Plan



# Board Work Plan Process

1. Board member requests Senior Corporate Governance Specialist to add topic to Parking Lot
2. At the next regular monthly All Committee meeting, the Board as a whole discusses with SMT Parking Lot items to move to Board Work Plan. The following steps occur once an item is moved to the Work Plan:
  - a. Evaluate and determine resource requirements and availability of resources to complete research, etc. [Board Chair/Committee Chair/CEO]
  - b. Confirm proposed steps and timing of when work will be reasonably completed [Board Chair/Committee Chair/CEO]
  - c. Insert “Target Completion Date” on Board Work Plan [Senior Corporate Governance Specialist]
  - d. Provide regular updates to Board and public on items [Committee Chair]
  - e. If assignment of a particular topic to a standing committee is unclear, determine if an ad hoc committee should be created [Board Chair]
3. When appropriate, topic moves from Board Work Plan to SMT agenda for Board meeting Report (Discussion or Presentation), or Action

*Note the process outlined in Step 2 is iterative and could repeat for many months before going to Step 3 for Board presentation and/or action.*

2021 Agenda Planning Calendar

**BOARD IDENTIFIED WORK PLAN PRIORITIES**  
(as of 10/15/21)

TOPIC	ACKNOWLEDGED	CMTE	ELT	STATUS	STATUS DESCRIPTION	TARGET COMPLETION DATE
SD-1: Strategic Foundation Monitoring Report Discussion and Refinement	2/12/2021	GOV	Focht	Work In Progress	4/13/21 All Cmtes discussion: Yoder, Burke and Focht discussed SD-1 monitoring report 4/14/21; Per 5/13/21 Governance pre-cmte, SMT will share revised format of monitoring report with the Cmte; Per 7/2/21 pre-cmte, Yoder/Focht updated committee on discussion during 8/12/21 and 9/9/21 pre-cmte meetings; discussed during the 10/5/21 Board Workshop, including the intent to finalize approach and start using in 1Q 2022.	
Governance discussion re: handling of concepts that span multiple SDs	2/12/2021	GOV	Focht	Work In Progress	4/13/21 All Cmtes discussion: Yoder to define potential scope for discussion with Governance Committee; Per 5/13/21 Governance pre-cmte, to be considered as a topic for the 2021 Governance Workshop; discussed briefly during the 10/5/21 Board Workshop; pending review of meeting synopsis will determine best action to move forward.	
SD-7: Environmental Stewardship (Next monitoring report 10/19/21)	10/5/2021	SM	TBD	Not Started	Systems Committee has discussed the upcoming results of the energy modeling and comprehensive Strategic Initiative: Decarbonization work, and then discussed with the entire Board during the 10/5/21 Board Workshop. Discussion about an update to include interim metrics for carbon emissions reduction is expected after this work is completed and presented. Status: Staff work in process.	
SD-11: Economic Development Policy Revision (Next monitoring report 11/16/21)	1/19/2021	PI	Olson	Work In Progress	Yoder shared notes with PI Cmte on 2/9/21; PI Cmte consensus on 3/9/21 that other Board work and policy revisions should be prioritized at this time; The PI Cmte intends to reconsider the potential prioritization of SD-11 and SD-13 in late 2nd/early 3rd quarter 2021; 5/11/21 PI Cmte members will review SD-11 documents and target June/July for pre-cmte discussion; 6/8/21 PI Cmte consensus to put SD-11 on agenda for discussion at Board Governance Workshop; Discussed at 10/5/21 Board Workshop; PI Committee to review	



2021 Agenda Planning Calendar

**BOARD IDENTIFIED WORK PLAN PRIORITIES**

(as of 10/15/21)

TOPIC	ACKNOWLEDGED	CMTE	ELT	STATUS	STATUS DESCRIPTION	TARGET COMPLETION DATE
SD-13: Stakeholder Outreach & Engagement (Next monitoring report 10/19/21)	1/19/2021	PI	Olson	Work In Progress	Yoder shared notes with PI Cmte on 2/9/21; PI Cmte consensus on 3/9/21 that other Board work and policy revisions should be prioritized at this time; The PI Cmte intends to reconsider the potential prioritization of SD-11 and SD-13 in late 2nd/early 3rd quarter 2021; 5/11/21 PI Cmte members will review SD-13 documents and target June/July for pre-cmte discussion; 6/8/21 PI Cmte consensus to put SD-13 on agenda for discussion at Board Governance Workshop; Discussed at 10/5/21 Board Workshop; PI Committee to review	
SD-9: Resource Planning Policy Revision (Most recent monitoring report approved 8/17/21; next monitoring report tentatively August 2022)	8/26/2020	SM	Fisher / Fernandez	Work In Progress	System Committee (Mollhoff, Williams, Moody & Yoder) discussion 12/3/20; Met 1/7/21; Met 1/25/21; per 3/31/21 meeting, Williams spoke with Bogner and Burke re scope, prioritization and timing; SMT discussed on 5/12. Board discussed during the October 5 workshop. Management will provide a draft to Systems Committee for review/comment before end of 2021.	
SD-2: Rates Policy Revision (Most recent monitoring report approved 6/15/21; next monitoring report tentatively June 2022)	8/26/2020	FIN	Thurber	Work In Progress	Finance Cmte discussed 4/2/21; Management will provide a proposal to replace the 5-year no-general rate increase language in the current SD-2. The Committee Chair provided proposed language to address the concept of affordability in SD-2, which was discussed at the July 1, August 4, and Sept. 3 pre-cmte meetings. Discussed at 10/5/21 Board Workshop and 10/8/21 pre-cmte meeting; Committee discussion re: revising SD-2 in two phases: (i) update rate freeze language and (ii) incorporate other rate considerations; Committee discussion will continue at next pre-committee scheduled for 11/5/21.	
SD-4: Reliability Policy Revision (Most recent monitoring report approved 4/13/21; next monitoring report tentatively April 2022)	8/26/2020	SM	Via	Not Started	System Committee to propose revisions related to resiliency. Awaiting external guidance from SPP et al. Board discussed during the 10/5/21 Board Workshop. Plan is for the Systems Committee to begin revision efforts after SD-9 is revised.	

**BOARD IDENTIFIED WORK PLAN PRIORITIES -  
COMPLETED**

TOPIC	ACKNOWLEDGED	CMTE	SMT	STATUS	STATUS DESCRIPTION	TARGET COMPLETION DATE
SD-7: Environmental Stewardship (Next monitoring report 10/19/21)	1/19/2021	SM	Fisher	Completed	Revise policy to include statement on climate change; System Cmte discussed proposed language 3/10/21; System Cmte reviewed and finalized changes 3/31/21 and recommended to Board during 4/13/21 meeting; Public comment period through Friday, May 14; Discussed during 5/18/21 All Cmtes meeting; Board approved 5/20/21	5/20/2021
BL-5: Unity of Control Policy Revision	8/26/2020	GOV	Focht	Completed	Proposed revisions reviewed by Gov Cmte 9/10/20; Gov Cmte determined more review required; Board approved 12/9/20	12/9/2020
BL-7: Delegation to the President & CEO	8/26/2020	GOV	Focht	Completed	Revise policy with regard to communication from CEO; Board approved 9/17/2020	9/17/2020
GP-4: Agenda Planning	8/26/2020	GOV	Focht	Completed	Revise policy to include development of a Board Work Plan; Board approved 9/17/2020	9/17/2020
BL-9: Delegation to President & CEO - Local, State and Federal Legislation and Regulation -- Legislative Resolution	2019	PI	Olson	Completed	Discussed in PI Cmte and with full Board in August and September 2020; referred back to PI Cmte for further review; 10/13/20 All Committee meeting determined to include topics of interest in OPPD's annual legislative agenda and the PI Cmte and Board would receive timely updates on emerging issues and positions.	10/13/2020

2021 Agenda Planning Calendar

**PARKING LOT - For Board Discussion**

TOPIC	SUGGESTED BY	ACKNOWLEDGED	STATUS
SD-1: Strategic Foundation Monitoring Report Discussion and Refinement <b>MOVED TO BOARD WORK PLAN 10/14/21</b>	Yoder	2/12/2021	4/13/21 All Cmtes discussion: Yoder, Burke and Focht discussed SD-1 monitoring report 4/14/21; Per 5/13/21 Governance pre-cmte, SMT will share revised format of monitoring report with the Cmte; Per 7/2/21 pre-cmte, Yoder/Focht updated committee on discussion during 8/12/21 pre-cmte
Governance discussion re: handling of concepts that span multiple SDs <b>MOVED TO BOARD WORK PLAN 10/14/21</b>	Yoder	2/12/2021	4/13/21 All Cmtes discussion: Yoder to define potential scope for discussion with Governance Committee; Per 5/13/21 Governance pre-cmte, to be considered as a topic for the 2021 Governance Workshop
Ad Hoc Committee on Market Transformation	Gov Workshop discussion	8/26/2020	4/13/21 All Cmtes discussion: Paused; SD-9 potential revisions may address part of this topic



# Reporting Item

## BOARD OF DIRECTORS

October 19, 2021

### ITEM

Power with Purpose Report

### PURPOSE

Provide updates on the Power with Purpose project for October 2021.

### SOLAR FACTS

- 1. Evaluating for interconnection risk mitigation options and additional solar projects to meet Power with Purpose resolution.

### FUEL SUPPLY FACTS

- 1. Natural gas supply infrastructure agreement has been executed with Northern Natural Gas (NNG) for the Turtle Creek Station. Natural gas supply infrastructure and gas supply agreements coordinated with a land lease are being finalized with Metropolitan Utilities District (MUD) for Standing Bear Lake Station.

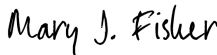
### NATURAL GAS FACTS

- 1. Zachry Industrial Inc. has been selected as the Engineer, Procure, and Construct (EPC) vendor for both the Turtle Creek and Standing Bear Lake Stations' generation facilities and substation infrastructure.
- 2. Preliminary grading continues at both Turtle Creek Station and Standing Bear Lake Station through the remainder of 2021. Associated technical assessments of both project sites continue in parallel with the grading.

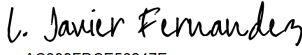
### ENERGY DELIVERY FACTS

- 1. The Public Hearing for the Sarpy Southwest Transmission Project was held October 5, 2021. OPPD will continue communicating with landowners and answering questions, with easement negotiations beginning 30 days after the hearing.

#### RECOMMENDED:

DocuSigned by:  
  
 \_\_\_\_\_  
 Mary J. Fisher  
 Vice President – Energy Production and Nuclear Decommissioning

#### APPROVED FOR REPORTING TO BOARD:

DocuSigned by:  
  
 \_\_\_\_\_  
 L. Javier Fernandez  
 President and Chief Executive Officer

MJF:sae

Information as of October 1, 2021



# Power with Purpose Update October Open Committee Meeting

October 19, 2021



# Updates

- Natural Gas Generation Project
- Solar Strategy
- Sarpy Southwest Transmission Project

# Natural Gas Generation Project & Fuel Supply Update

- On September 22, OPPD executed a contract with Zachry Group for the Engineer, Procure, and Construct (EPC) of our two new natural gas generation facilities and their associated substations
- Preliminary grading is underway at both Turtle Creek Station (TCS) and Standing Bear Lake Station (SBL) and continues through 2021
- Metropolitan Utilities District’s board authorized approval of ground lease and main extension agreement on October 6; approval to occur with finalized gas supply agreements
- Community engagement
  - Meet with City of Papillion for project update (TCS)
  - Attend annual Rambleridge Homeowners Association Meeting in November (SBL)

Project Schedule	Milestone (Past/Future)
TCS Earthwork Begins	August 2021 ✓
SBL Earthwork Begins	September 2021 ✓
EPC Contractor Award	September 22, 2021 ✓
SBL & TCS Construction Starts	Quarter 1, 2022
SBL Commercial Operation	May 1, 2023
TCS Commercial Operation	August 18, 2023

*Information as of October 7, 2021*

# Standing Bear Lake Station Preliminary Grading



As of October 6, 2021



# Turtle Creek Station Preliminary Grading



As of October 6, 2021

# Solar Strategy

- Where We've Been
- What We've Learned
- Where We're Going

# Where We've Been

- Issued first utility-scale solar sourcing in November 2019
  - Proposals received indicated a variety of projects across Nebraska in varying stages of development
- Executed Platteview Solar PPA in Spring 2021
  - This is the first utility-scale solar PPA for OPPD and the State of Nebraska!!
- Closed out first phase of sourcing in Summer 2021

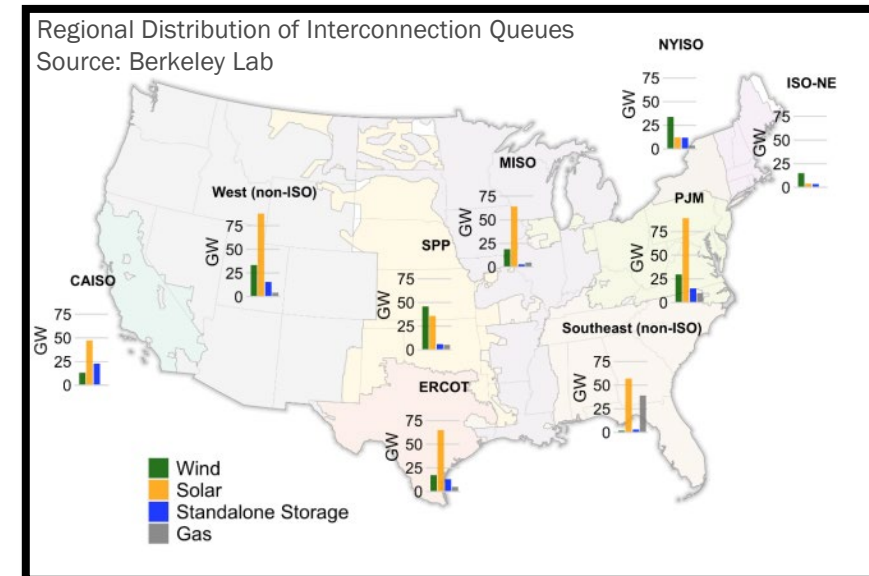
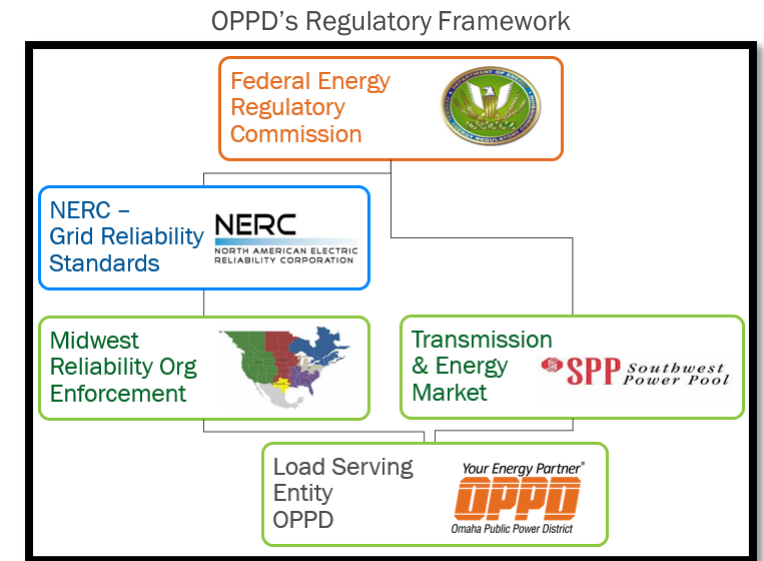


# What We've Learned

- Compiled numerous lessons learned across the project team, focusing on:
  - Business strategy
  - Sourcing, negotiations, and contracting
  - Generator Interconnection (GI) process complexity
  - Community and Stakeholder
- Key challenges to first phase of solar sourcing:
  - Solar industry and supply chain experienced significant challenges in 2020 – 2021
  - State, federal, and FERC policy constraints
  - Evolving solar regulations for local planning and zoning jurisdictions
  - Generator interconnection process has a significant backlog, adding significant risk to projects

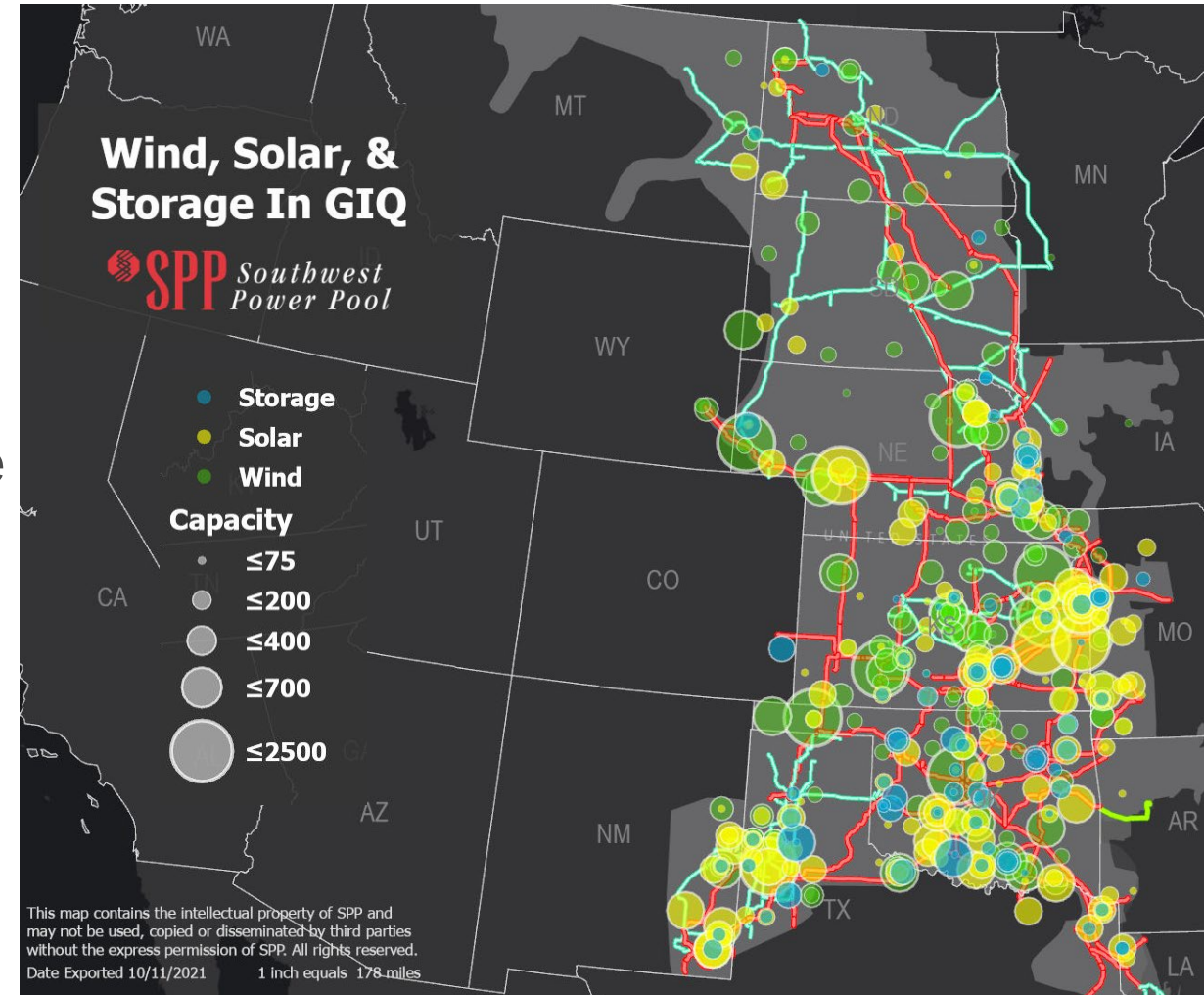
# National Challenges with Generation Interconnection to the Transmission System

- OPPD is an owner and operator of the Bulk Electric System, and has a regulatory obligation to comply with federal requirements
- OPPD is required to comply with federal interconnection processes for new generation
  - Processes ensure reliability and “Open Access” of the transmission grid
- Interconnection study backlogs have formed across the country, resulting from:
  - Increasing volume and magnitude of interconnection requests from developers of emerging technologies
  - Paradigm shift is a significant challenge for the current FERC policy landscape



# Impacts of the GI Backlog

- FERC-regulated GI processes have multi-year backlogs of requests
  - Study results dictate transmission expansion costs for new generators
- Impact to PwP Solar
  - Proposals received in solar sourcing were impacted by the backlog with an unknown cost risk
  - Potential interconnection cost risk unclear until study process is completed (multi-year)
- OPPD is developing strategies to reduce these risks for solar projects



# Where We're Going



# Where We're Going

- Continue commitment to the November 2019 BOD resolution
  - Cease coal operations at North Omaha Station by end of 2023
  - Projects initiated to support fuel conversion of North Omaha Station by spring 2024
- Pursue a GI strategy that mitigates uncapped risks
  - OPPD is actively engaged with regulatory bodies (FERC, SPP) to understand best mitigation strategies to interconnect generation and serve load
- Incorporate evolving energy policy changes in remaining solar projects
  - Federal infrastructure proposal may benefit OPPD's solar projects
  - FERC's Advanced Notice of Proposed Rulemaking (ANOPR): Building for the Future Through Electric Regional Transmission Planning and Cost Allocation and Generator Interconnection



# PwP Solar 2.0 Strategy



# Next Steps: Q4 2021

- Adapt strategy and timeline in alignment with any policy changes (as needed or required)
  - Incorporate any impacts from federal, FERC, SPP, or local policy changes
- Continue solar education and advocacy
  - Meet with Community Leaders
  - Continue support of local planning and zoning efforts
- Project development strategy
  - Research options that mitigate Generator Interconnection risks
  - Conduct financial, technical, and legal due diligence, including execution risk assessments
  - Layout sourcing strategy for projects

# Sarpy Southwest Transmission Project Public Hearing



# SSWTP - Public Hearing

Objective - Allow directly impacted landowners to learn about next steps and ask questions about the project and the easement acquisition process.

- Agenda
  - Project Overview
  - Property Owner Rights
  - Construction
  - Comments, Q&A
- Attendance
  - 27 Attendees\*
  - 23 in-person, 4 virtual
- Q&A Themes
  - Negotiations, offers, appraisals
  - Alignment selection
  - Compensation methodology

\*Independent participants not including OPPD & HDR team members

## What We've Done

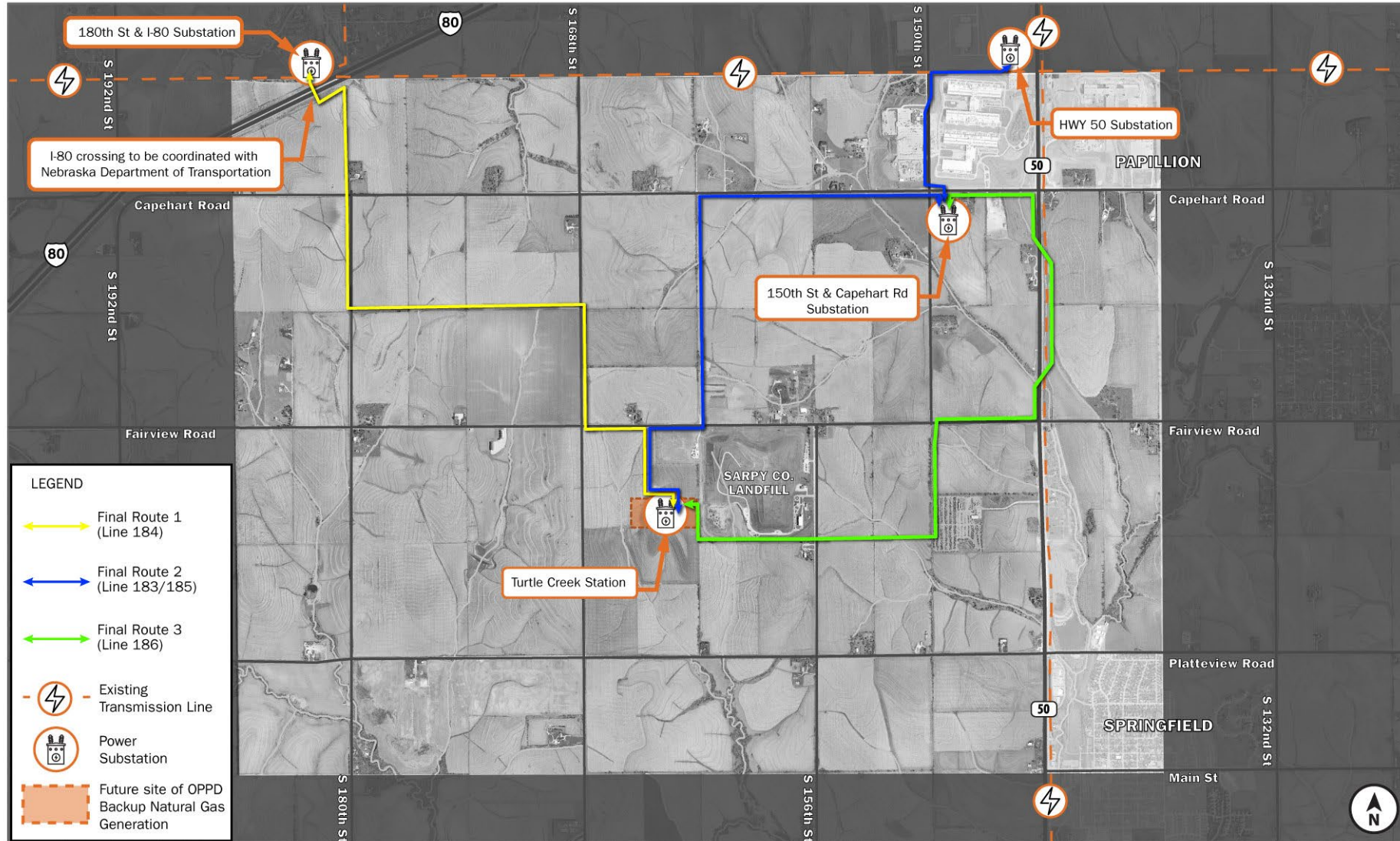
- ✓ November 2020 – February 2021  
Phase 1: Identify Study Area and Environmental Constraints
- ✓ January 26, 2021  
Phase 1: Online Public Meeting
- ✓ February 2021 – March 2021  
Phase 2: Route Segment Analysis
- ✓ March 30, 2021  
Phase 2: Online Public Meeting
- ✓ April 2021 – May 2021  
Phase 3: Route Alternative Analysis
- ✓ May 2021  
Final Route Announcement

## Where We're Going\*

- May 2021 – January 2022  
Engineering/Design/Right-of-Way Activities
- October 5, 2021  
Public Hearing
- October 2021 – October 2022  
Procurement
- November 2021 – March 2022  
Easement Acquisition
- May 2022 – June 2023  
Construction
- May 2023 – December 2023  
Property Restoration and Project Closeout

*\*All dates are subject to change and may differ from previous versions*

# Final Route Alignments



## Sarpy Southwest Transmission Project

Final Route Alignments  
September 2021

# Strategic Initiative: Pathways to Decarbonization

## BOD Update October 2021

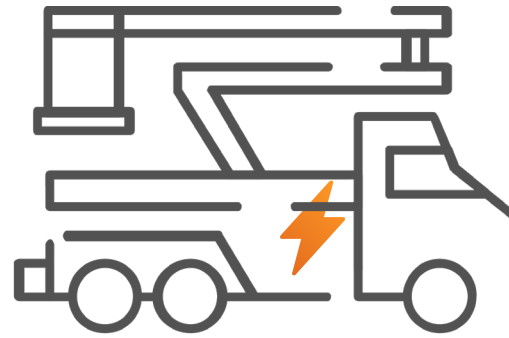
Colton Kennedy, Jamie Wagner, Paul Fortney, Ryan Stigge  
October 19, 2021

NET-ZERO CARBON  
PRODUCTION  
BY **2050**

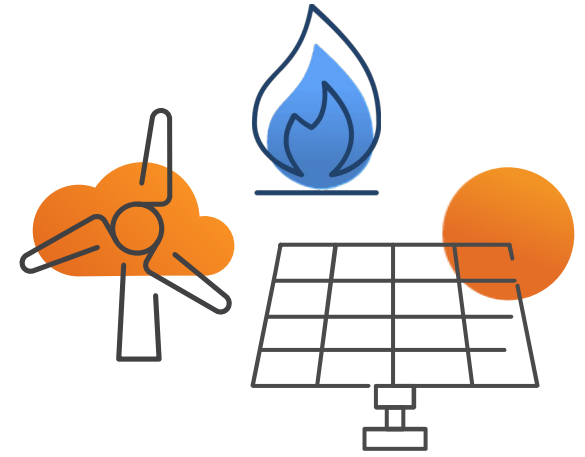


# Agenda

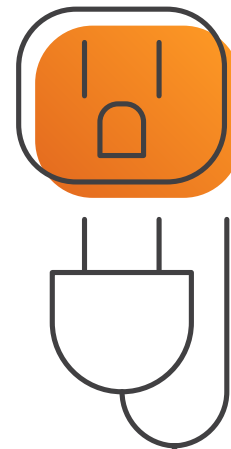
- Energy Portfolio Project Update
- Customer Project Update
- Community Project Update
- Internal Operations Project Update
- Stakeholder Outreach Update



Internal Operations



Energy Portfolio



Customer  
Products & Services



Community Partner

# Leading the Way

Pathways to  
Decarbonization

# We Power the Future

Technology  
Platform



Electric System Evaluation  
& Modernization

Powering the  
Future  
2050

Workforce  
Transformation



Customer Engagement  
for the Future





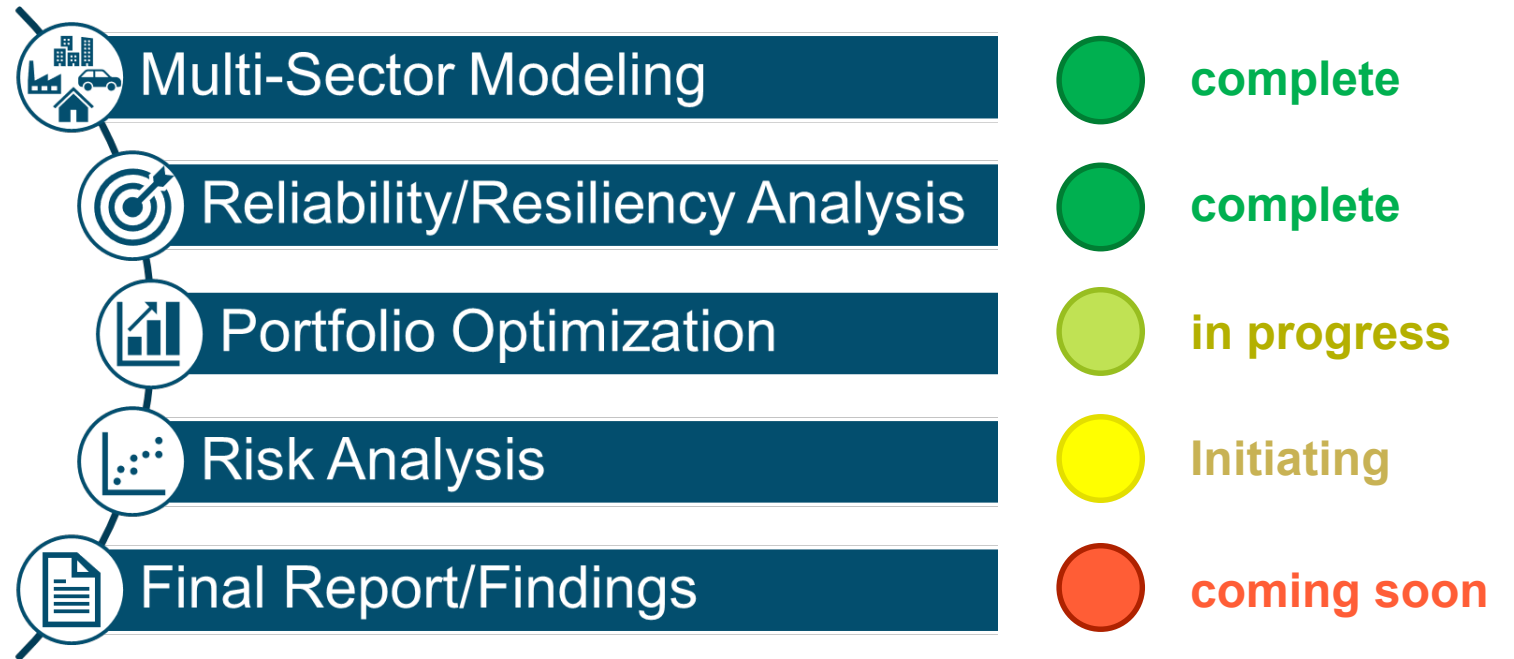
# Decarbonization: Energy Portfolio Project



# Project Status

- Progress

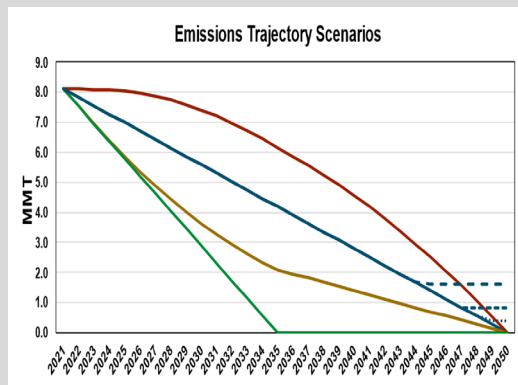
- Multi-sector modeling gives a clear view of future energy demand
- A robust modeling framework will ensure a broad and deep evaluation of alternatives
  - Broad set of technologies
  - Robust resource adequacy analysis
  - Holistic integrated market analysis
- Stakeholder voices have been heard and incorporated throughout
  - Questions have been answered
  - New scenarios have been added



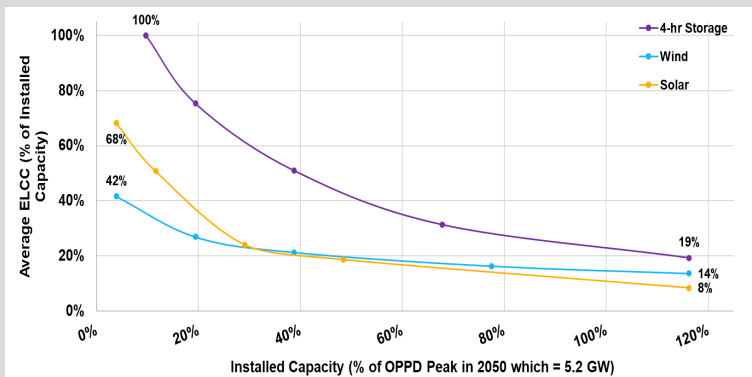
# Current Activities

- Portfolio Modeling
  - Developing optimized portfolios based on emissions targets, technology and cost assumptions, and resource adequacy constraints
  - OPPD and E3 teams are undergoing extensive model testing and results validation
  - The full set of draft results being prepared

## Emissions Targets



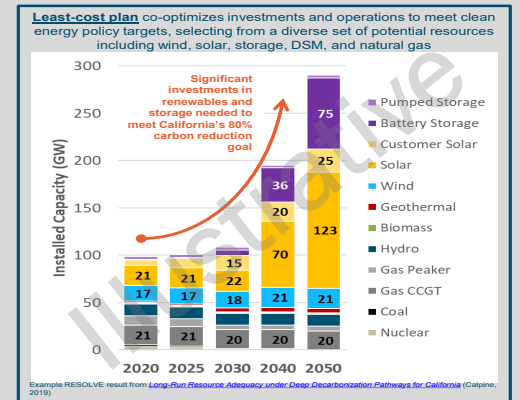
## Resource Adequacy ELCC Results



## Portfolio Sensitivities

	Assumption
Framing Scenarios Assumptions	Pace of Decarbonization
	Technology Availability
Sensitivity Scenarios Assumptions	Multi-Sector electrification
	Negative emissions technologies
	Technology costs
	Carbon pricing
	SPP Resource Mix
	GHG import/export accounting
	Flexible Loads

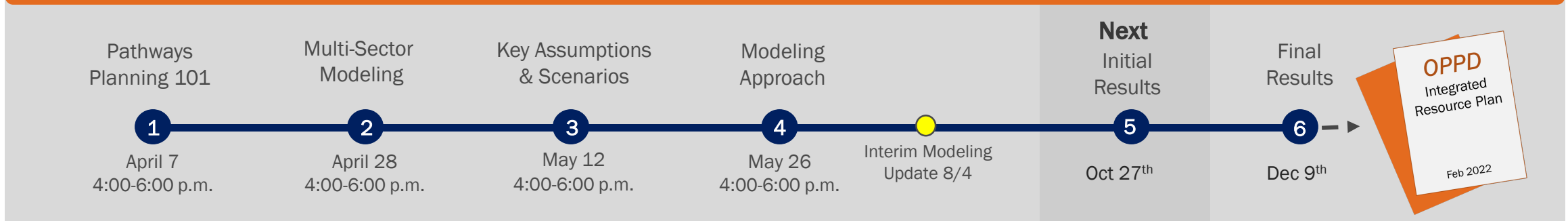
## Portfolio Optimization



# Upcoming Activities

- Share Initial Results in Workshop #5 (Oct 27<sup>th</sup>)
- Incorporate stakeholder feedback and additional scenarios or modifications
- Conduct detailed system modeling on initial portfolios
  - Operational flexibility modeling
  - Transmission power flow modeling
  - Detailed economic and risk modeling
  - Resiliency review
- Prepare Final Results for Workshop #6 (Dec 9<sup>th</sup>)
- Publish draft Integrated Resource Plan incorporating Decarbonization: Energy Portfolio modeling results (Jan TBD)

## Energy Portfolio: Stakeholder Workshops





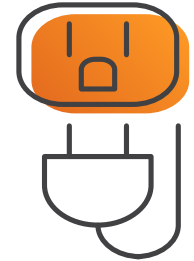
# Decarbonization: Customer Project



# Customer Project

## Goals and Deliverables:

- Develop repeatable process focused on helping customers lower their personal carbon footprint through OPPD programs, products and education
- Key Deliverables:
  - Product strategy
  - Product roadmap
  - Acceleration plan



Customer  
Products & Services

## Completed Activities:

- Developed and piloted repeatable product evaluation framework
- Completed Phase I Analysis of 228 concepts covering all aspects of decarbonization
- Completed Phase II detailed research and analysis on the 26 top scoring concepts from Phase I
- Residential customer prioritization surveys (Power Panel, Stakeholder Workshop, OPPD Community Connect)

# Product Concept Analysis & Scoring

## Phase I

### Scoring Criteria:

- Target Market
- Customer Value Prop
- Brand Reputation & Customer Experience
- Industry Successes
- Risk to Infrastructure
- Cost/Technology Limitations
- Decarb Benefit
- Other Benefits (DSM, revenue, etc.)
- Feasibility/Complexity Effort Score (tiebreaker)



## Phase II

### Scoring Criteria:

- Financial (ROI)
- Carbon Reduction Impact
- Customer Impact/Satisfaction
- Market Penetration
- Innovation Brand Reputation
- Operational Efficiency
- Oversight

### Additional Analysis Includes:

- High level product design
- Target market analysis
- Annual ramp/penetration
- Value prop to OPPD and Customer
- Cost estimate to implement
- Annual run budget including FTE
- Detailed decarb savings analysis
- Estimated scale of other benefits (DSM, revenue, etc.)

## Overall Assumptions:

- 3-5 year view for each concept
- Existing products not included in phase II evaluation
- Enabling capabilities such on-bill financing or AMI are part of the strategy but weren't evaluated as products



# Phase I & II Research & Scoring Highlights

## Phase I (228 Concepts Scored)

- High-level research, focus on successful product designs and successes within the Industry
- Focus on ensuring a wide range of ideas covering all customer segments and product areas
- Sample of product concepts explored:
  - Net Zero Construction
  - Heat Pump Water Heaters
  - Commercial Refrigeration
  - White Roof Conversions
  - Variable Frequency Drive Rebates
  - Fuel Cells
  - Mass Transit EV Adoption
  - Customer Owned Solar
  - Composting
  - Home Energy Rating Report/ High Bill Alerts
  - Solar Coins (BitCoin for EE)
  - Residential Wind
  - Neighborhood Solar
  - Battery Storage
  - Plastic, Metal and Glass Recycling
  - BioEnergy with Carbon Capture
  - Native American Support Programs
  - Heat Recovery (Heat Exhaust Generation)

## Phase II (26 Concepts Scored)

- Benchmarking of other utilities programs (scale/growth, budget, GHG savings)
- Final roadmap prioritization, based upon team scoring and OPPD Market Research
- Top 10 scoring product concepts (no particular order):
  - C&I Community Solar
  - Energy Star Appliance Rebates
  - Commercial Outdoor Lighting & Controls
  - Residential Shade Trees
  - Commercial Food Service Equipment
  - Residential Lighting & Controls
  - Electric Yard Equipment Program
  - Community Solar Expansion
  - Residential Weatherization
  - Commercial EV Fleet Adoption





# Energy Portfolio Linkage

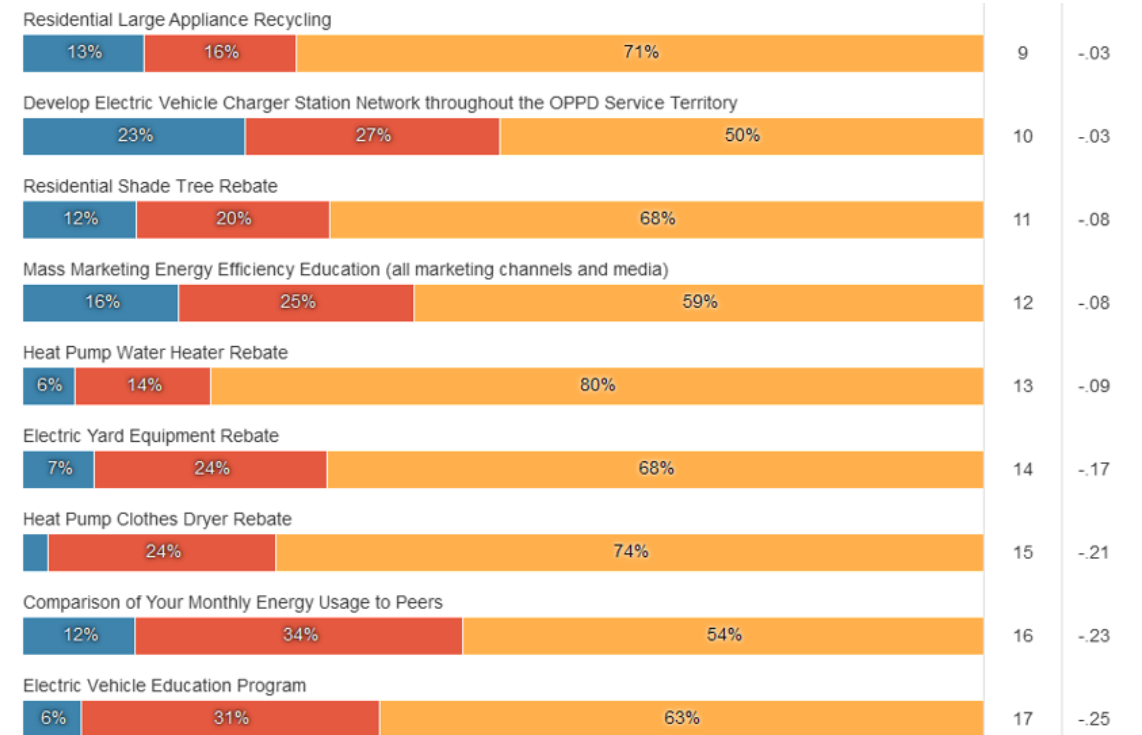
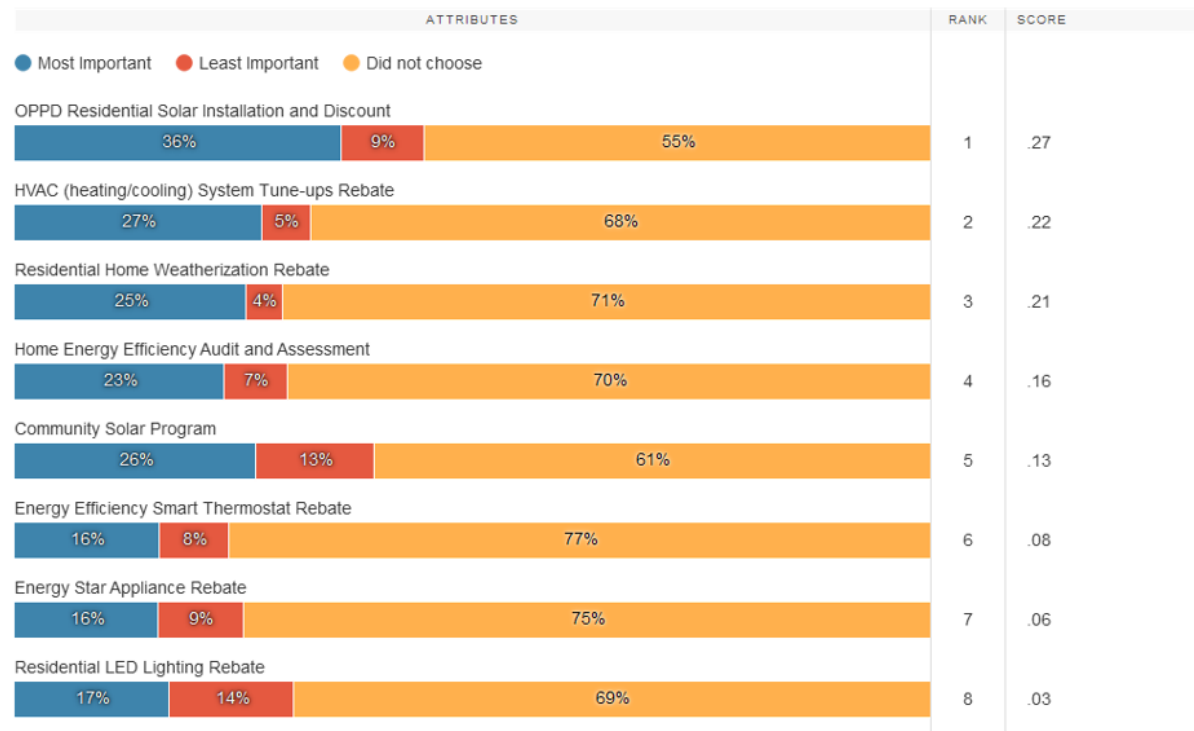
- Initial Energy Portfolio findings indicate there may be substantial opportunity for energy efficiency, load flexibility, and significant increases in renewable resources, particularly in wind and solar generation
- Customer focused programs may be part of achieving these Energy Portfolio driven outcomes:
  - Energy Efficiency
    - Future potentiality studies will include the increasing benefits of energy efficiency to OPPD's portfolio and consider long-run synergies with electrification and economy-wide decarbonization
  - Behind-the-Meter Solar
    - Both a Technical Potentiality and Customer Adoption study will guide opportunities for satisfying OPPD's overall renewable portfolio with customer generation
- As specific opportunities are identified, both feasibility and cost/benefit analysis will need to be performed

# Residential Study: Residential Concept Prioritization

## Q7 Importance

When thinking about what OPPD should prioritize to potentially help you reduce your carbon footprint, which ONE of the items/actions below do you feel is most important and which ONE is least important? Click here for more details of each item/action.

Total responses: 433



# Customer Workstream Next Steps

Finalize  
Market  
Research

- October 2021

Acceleration  
Plan

- October 2021

Strategy  
Narrative

- November 2021

Operational  
Plan

- December 2021

Target  
Completion

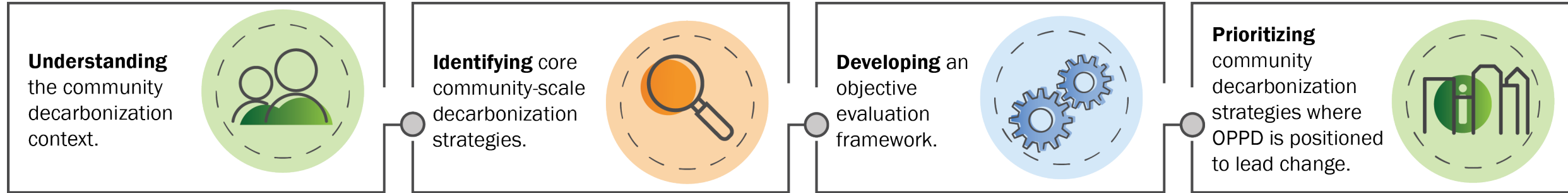
- December 2021



# Decarbonization: Community Project



# Community Decarbonization Approach & Objectives



- **Consider another vantage point**, encompassing community-scale decarbonization strategies that reach beyond those traditionally considered by electric utilities.
- Prioritize **areas of focus** and identify potential partners to make meaningful impacts across service territory communities.
- **Position OPPD to lead community initiatives** in the transition towards a low-carbon future.

# Selected Climate Action Plans

- **Regionally relevant**, targeting communities located primarily in the Midwest.
- **Recent Climate Action Plans**; varying level of detail for GHG mitigation measures.
- 4 of 6 communities declared a **climate emergency** in 2019.
- Connection to **peer utilities**, allowing benchmarking.



# EXPLORE 66 SHARED DECARBONIZATION & ADAPTATION STRATEGIES



ADAPTATION



BUILDINGS



ENERGY



FOOD



LAND USE



LEADERSHIP

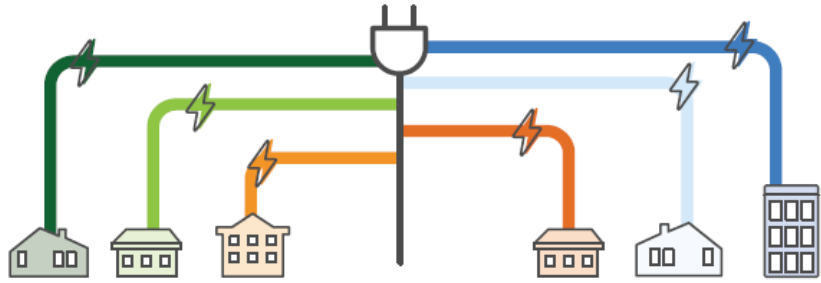


TRANSPORTATION



WASTE & RESOURCE  
MANAGEMENT

# Exploring Opportunity Areas



Advocating for Advanced Energy Codes and Green Building Standards



Accelerate the EV Transition



Addressing the Energy-Water Nexus



Supporting Distributed Generation



# Community Workstream Next Steps





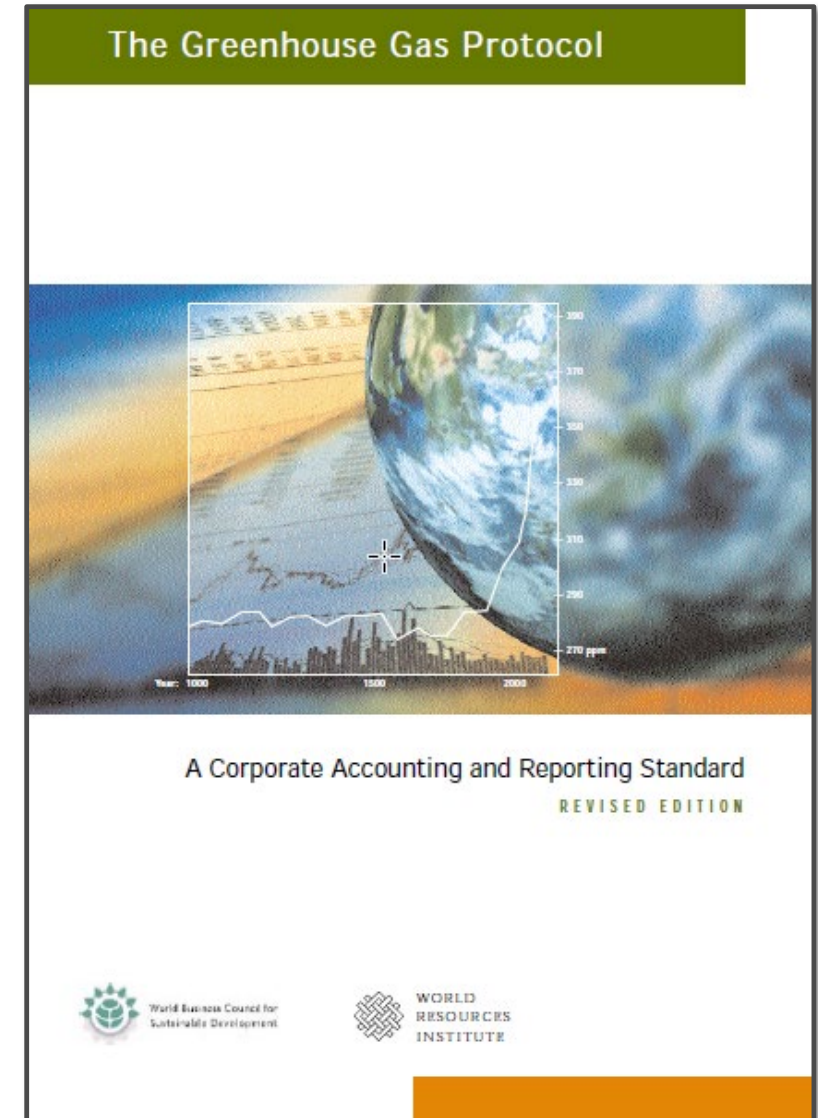
# Decarbonization: Internal Operations Project



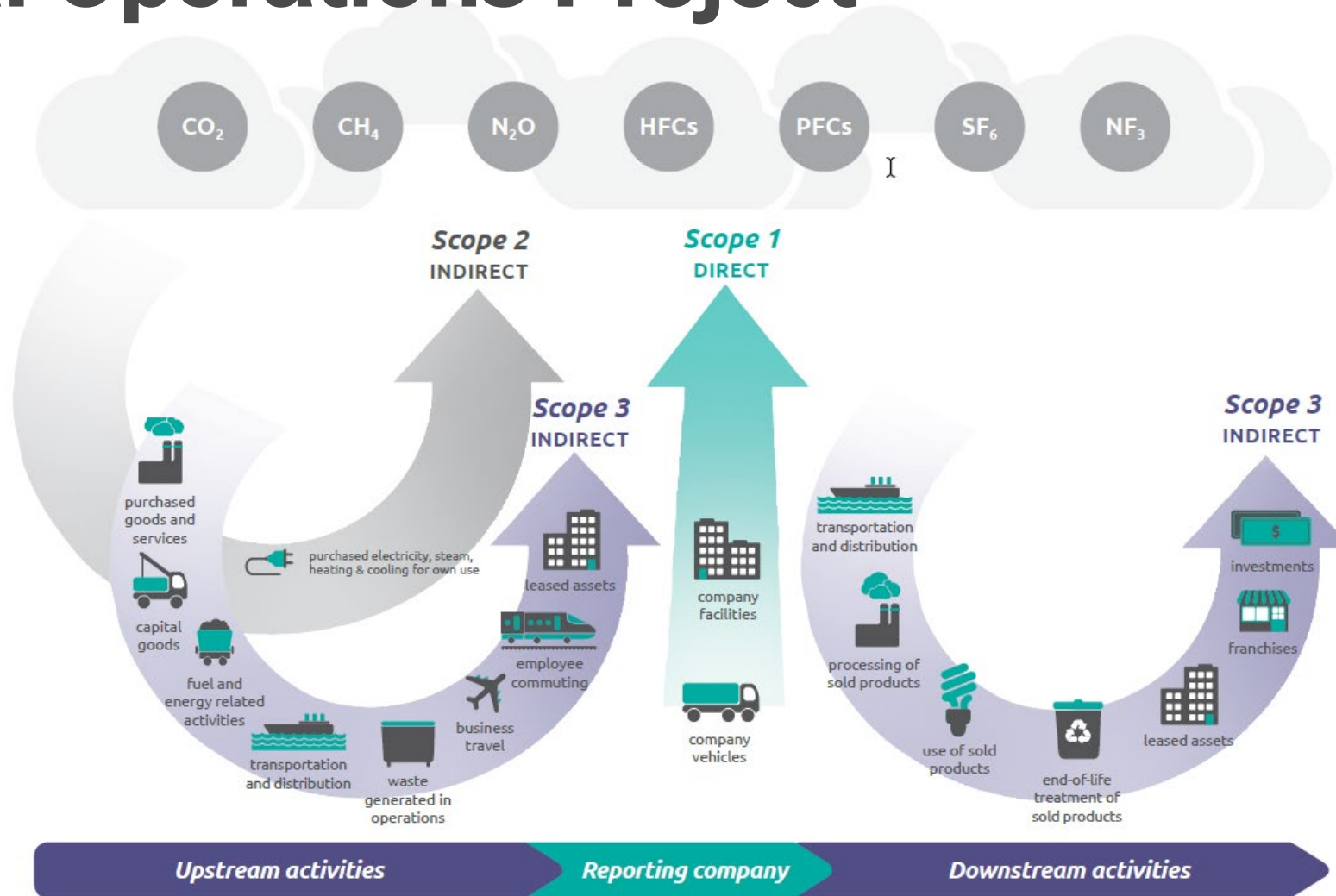
# Internal Operations

This project will create a base year greenhouse gas inventory for OPPD to form basis for monitoring progress towards net-zero carbon.

- GHG Protocol Corporate Accounting and Reporting Standard.
- Transition inventory and reporting to business to ensure repeatable and certifiable yearly.
- Initial scoping and characterization of projects to reduce OPPD's largest non-generation emission sources.
- Partner with business to build/revise current business processes to reflect OPPD's prioritization of reducing carbon impact.



# Internal Operations Project



Source: Figure 1.1 of Scope 3 Standard.

# Required: Scope 1 and Scope 2

## Scope 1 Emission Sources:

- Stationary Combustion Sources
  - Fossil Generation
  - Internal Combustion Engines: Emergency Engines, Auxboilers
- Mobile Combustion Sources
  - Vehicle Fleet
  - Equipment Propane
  - Coal Handling Equipment
- Process/Fugitive Sources
  - Refrigerants (facilities and transportation)
  - Coal Pile
  - T&D SF6 Leaks
  - Natural Gas Pipeline
  - Welding-Acetylene
  - Fire Suppression Systems

## Scope 2 Emission Sources:

- Purchased and Consumed Electricity
- T&D Losses

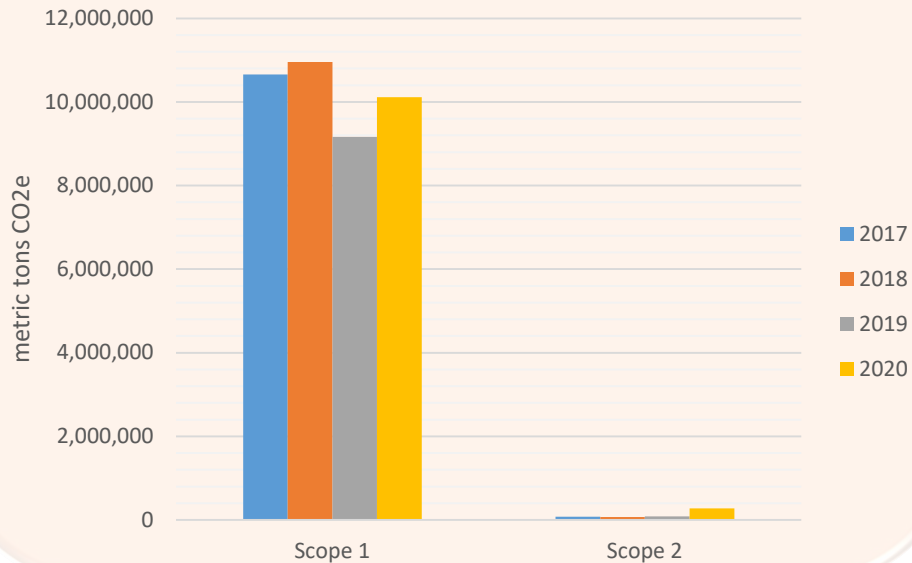
## Scope 3 Emission Sources:

- Purchased Goods and Services\*
- Energy and Fuel Related Activities
  - Coal Purchases
  - Coal Rail Transportation
  - Purchased Power Delivered to End-Users
  - Natural Gas Purchases
- Business Travel
- Employee Commute
- Waste

# Required: Scope 1 and Scope 2

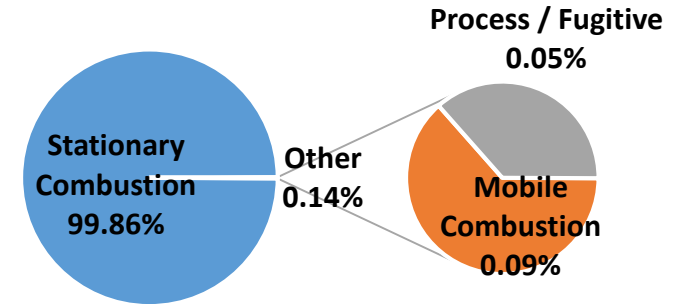
	Metric tons CO <sub>2</sub> e			
	2017	2018	2019	2020
<b>Scope 1</b>	10,657,608	10,951,779	9,161,659	10,113,613
<b>Scope 2</b>	73,646	69,581	84,601	272,634
	<b>10,731,254</b>	<b>11,021,359</b>	<b>9,246,260</b>	<b>10,386,247</b>

GHG Inventory



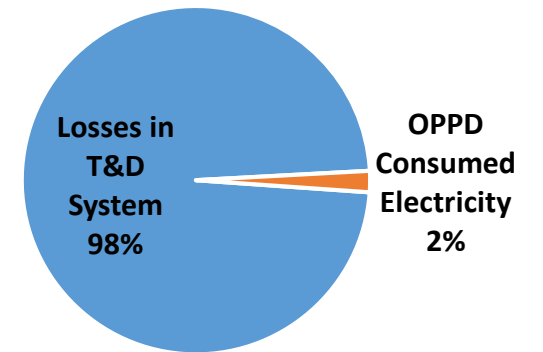
Scope 1	Avg Emissions
Stationary Combustion	10,206,850
Mobile Combustion	9,075
Process / Fugitive	5,237
<b>Total</b>	<b>10,221,161</b>

## Scope 1: Avg Emissions



Scope 2	Avg Emissions
Losses in T&D System	70,020
Purchased and Used Electricity	5,709
<b>Total</b>	<b>75,729</b>

## Scope 2: Avg Emissions



\* These data currently undergoing validation



# Decarbonization: Stakeholder Outreach



# Energy Portfolio Workshops

*April – December 2021*

## Objective:

- Provide a deeper dive of decarbonization planning process and how it will support OPPD's Integrated Resource Plan (IRP)
- Seek feedback along the way and explain how feedback was used or why not used

## Outcome:

- Higher satisfaction with process

## Outreach Levels (IAP2):

- Varied from Inform to Consult





# Decarbonization – Energy Portfolio Workshops

Approximately 100 people have  
attended one or more workshop

Many attended multiple  
workshops within the series

April 7	Pathways Planning 101
April 28	Multi-Sectoral Modeling
May 12	Developing Key Assumptions & Scenarios
May 26	Developing Modeling Approach
Aug. 4	Interim Modeling Update
Oct. 27	Initial Results
Dec. 9	Final Results

## Speakers Bureau Engagement

- MAPA – Natural Resources Committee
- Green Bellevue
- Sierra Club

# Decarb – Customer & Community Meeting

*September 2021*

## Community Objectives:

- Understand community decarb context; identify core community-scale decarb strategies; develop an objective evaluation framework and prioritize strategies

## Customer Objectives:

- Gather input for developing product to help customers lower their personal carbon footprint
- Deliver product strategy, roadmap and acceleration plan

## Outcome:

- Prioritize areas of focus to make meaningful impacts across service territory communities
- Position OPPD to lead community initiatives in the transition towards a low-carbon future

## Outreach Levels (IAP2):

- Consult



# OPPDCommunityConnect.com

*Launched July 2020*

## Engagement Platform Objective:

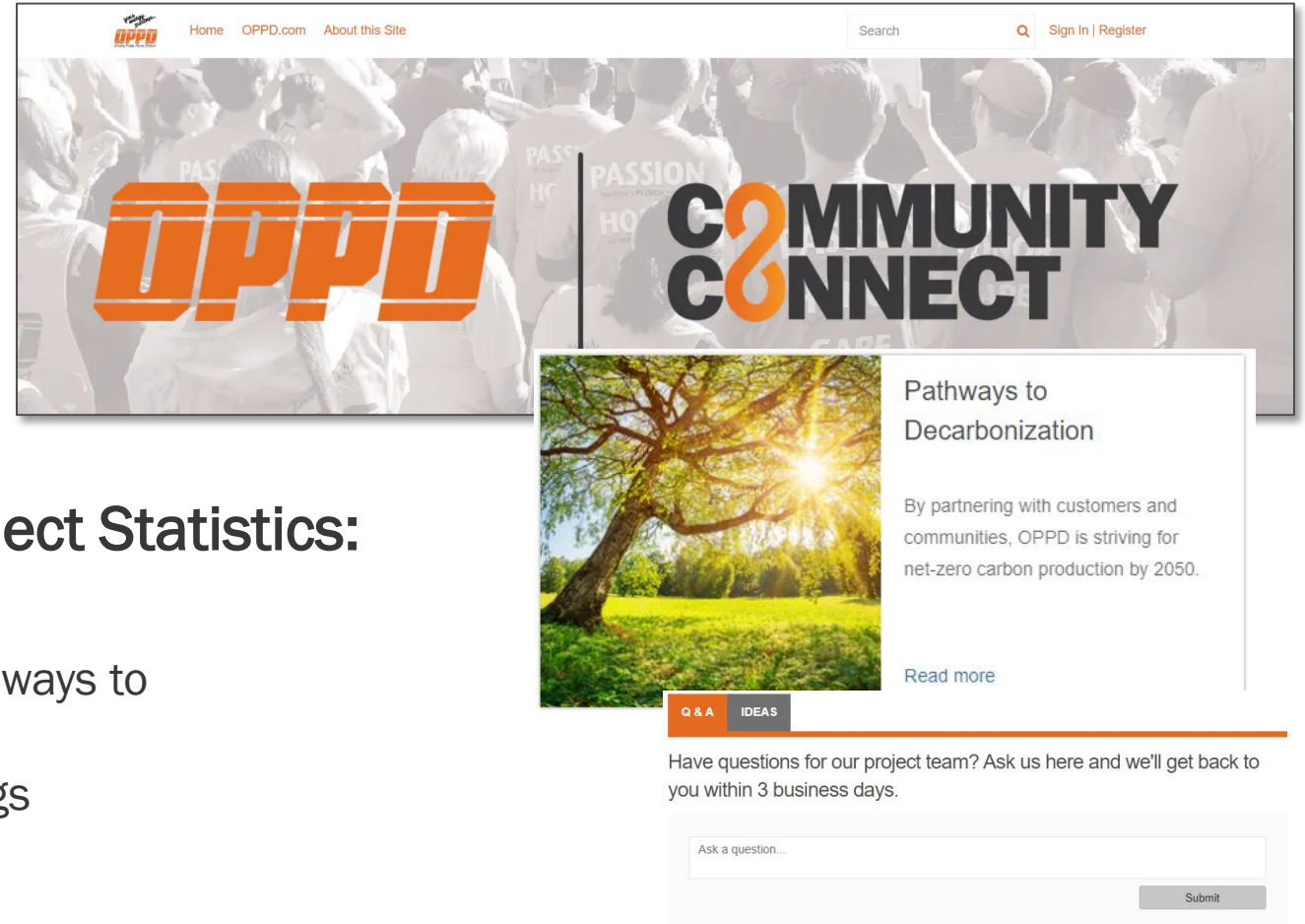
To lead the way; be the first and best source of Information and increase interaction

## Decarb Engagement Tools:

Q & A, Comments, Ideas, Quick Polls, Surveys

## Decarbonization OPPDCommunityConnect Statistics:

- **Projects**
  - 8 project pages created associated with Pathways to Decarbonization
  - Included workshop information and recordings
- **Visitors to Decarbonization project pages**
  - 7,700 between July 2020 thru Sept. 2021 (approximately 47,000 total site visitors)



Home OPPD.com About this Site Search Sign In | Register

# OPPD COMMUNITY CONNECT

## Pathways to Decarbonization

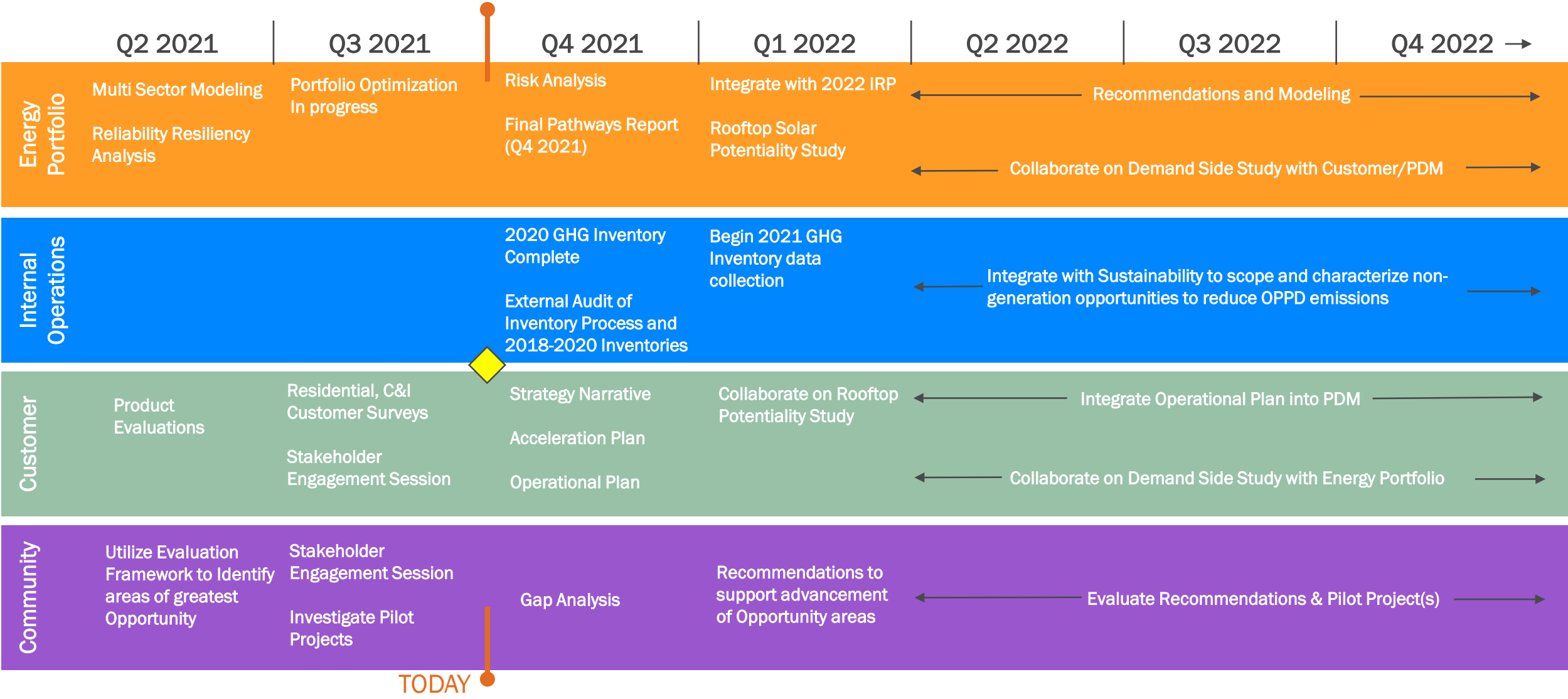
By partnering with customers and communities, OPPD is striving for net-zero carbon production by 2050.

[Read more](#)

Q & A IDEAS

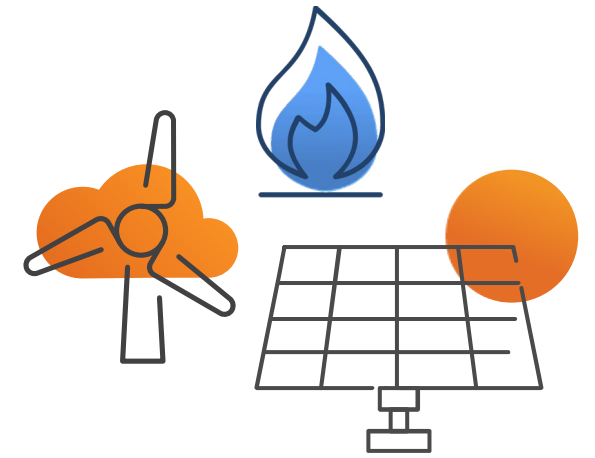
Have questions for our project team? Ask us here and we'll get back to you within 3 business days.

# Program Milestone Timeline



TODAY

ELT checkpoint/BOD update



# Questions, Discussion

